

The Project Gutenberg EBook of Illustrated Catalogue of Cotton Machinery, by Howard & Bullough American Machine Company, Ltd.

This eBook is for the use of anyone anywhere at no cost and with almost no restrictions whatsoever. You may copy it, give it away or re-use it under the terms of the Project Gutenberg License included with this eBook or online at www.gutenberg.org

Title: Illustrated Catalogue of Cotton Machinery

Author: Howard & Bullough American Machine Company, Ltd.

Release Date: December 14, 2011 [EBook #38301]

Language: English

Character set encoding: ISO-8859-1

*** START OF THIS PROJECT GUTENBERG EBOOK COTTON MACHINERY ***

Produced by Don Kostuch

[Transcriber's notes]

Page numbers in this book are indicated by numbers enclosed in curly braces, e.g. {99}. They have been located where page breaks occurred in the original book.

Obvious spelling errors have been corrected but "inventive" and inconsistent spelling is left unchanged.

Material suitable for searching has been converted to text. Complex tables that would not provide useful search targets and would be prone to transcription errors have been left as images.

[End Transcriber's notes]

{2}

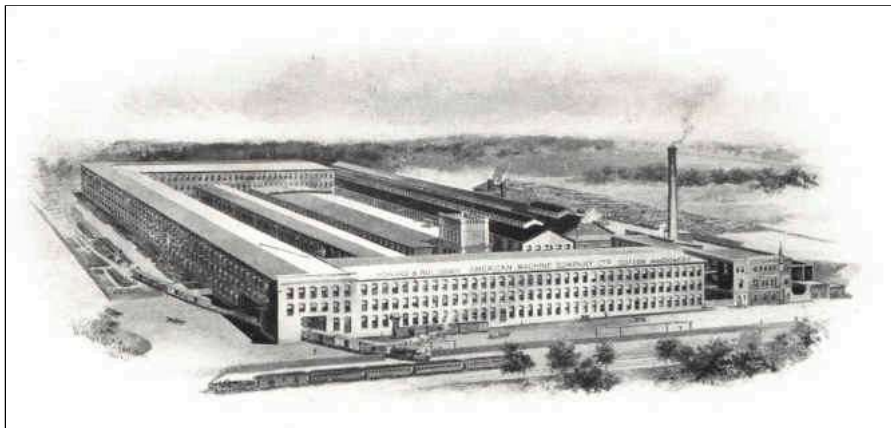

PLANT OF
HOWARD & BULLOUGH AMERICAN MACHINE COMPANY LTD.

PAWTUCKET, R. I.

{3}

ILLUSTRATED CATALOGUE of COTTON MACHINERY
ILLUSTRATED CATALOGUE

of

COTTON MACHINERY

Built by

HOWARD & BULLOUGH
AMERICAN MACHINE COMPANY, LTD.

PAWTUCKET, R. I., U. S. A.

OPENING, PICKING, CARDING, DRAWING, ROVING, SPINNING, TWISTING AND WINDING MACHINERY

WARPERS AND SLASHERS

Containing Also Floor Spaces, Speeds, Productions, Gearing Diagrams, Useful Tables and Other Information

1909

BOSTON OFFICE, 65 FRANKLIN STREET
C. E. RILEY, TREASURER

SOUTHERN OFFICE, EMPIRE BUILDING, ATLANTA, GA.

{4}

INTRODUCTION.

We take pleasure in presenting this book, trusting that the information it contains will be of interest and service.

In compiling this catalogue we have included such descriptive matter as will set forth the main features and advantages of our machinery, also outline drawings, gearing diagrams, floor spaces, speeds, production and other tables, and information of use to all those interested in Cotton Mills.

Some of the information contained in this book has hitherto been presented in circular and book form, but at the request of numerous friends and users of our machinery we now issue this complete catalogue which contains considerable additional information, besides which it is in a compact and convenient form.

Our machinery is extensively used, and is well and favorably known.

It will be our endeavor in the future to continue to make improvements and maintain the high standard which has characterized our machinery in the past.

{5}

INDEX.

OPENING AND PICKING MACHINERY	PAGE
Hopper Bale Opener	8
General Description	9
Floor Plans and Elevations	12
Automatic Hopper Feeder	14
Self-feeding Opener	16

Trunking	<u>20</u>
Breaker Lappers	<u>24</u>
Combination Machines	<u>30</u>
Intermediate and Finisher Lappers	<u>32</u>
Production Tables	<u>36</u>
Gearing Diagrams	<u>38</u>
Calculations	<u>43</u>
Floor Plans and Elevations	<u>52</u>
REVOLVING FLAT CARDS	
General Description	<u>61</u>
Patent Setting Arrangement for Flats	<u>67</u>
Williams' Patent Stripping Motion	<u>68</u>
Floor Plan	<u>72</u>
Gearing Diagram	<u>72</u>
Calculations	<u>75</u>
Production Tables	<u>75</u>
Gearing Tables	<u>77</u>
Clothing	<u>80</u>
DRAWING FRAMES	
General Description	<u>82</u>
Floor Plans	<u>88</u>
Table of Lengths	<u>90</u>
Production Tables	<u>91</u>
Gearing Diagram	<u>92</u>
Calculations	<u>94</u>
Gearing and General Tables	<u>96</u>
Electric Stop Motions	<u>98</u>
SLUBBING, INTERMEDIATE, ROVING AND JACK FRAMES	
General Description	<u>103</u>
Improved Differential Motion	<u>107</u>
Improved Lay Gearing	<u>109</u>
Speed Tables	<u>111</u>
Floor Plans	<u>118</u>
Tables of Lengths	<u>119</u>
Production Tables	<u>113</u>
Gearing Diagrams	<u>123</u>
{6}	
Calculations	<u>127</u>
Gearing Tables	<u>130</u>
Roving Tables	<u>136</u>
RING SPINNING FRAMES	

General Description	141
Improved Builder	151
H. & B. Separator	152
Floor Plan	154
Table of Lengths	155
Production Tables	156
Gearing Diagrams	160
Calculations	164
Gearing Tables	166
Yarn Twist Tables	176
Table for Numbering Cotton Yarn	179
Breaking Weights of American Yarns	184
SPOOLERS	
Table of Lengths and Productions	186
REELS	
TWISTERS	
General Description	188
Floor Plan	193
Table of Lengths	195
Production Tables	198
Gearing Diagrams	203
Calculations	206
Gearing Tables	208
Twist Tables	210
CONE AND TUBE WINDERS	
General Description	222
Floor Plan	225
WARPERS	
SLASHERS	
MISCELLANEOUS	
Shipping Weights	232
Table of English Weights and Measures	233
Classification of Cotton	237
General Rules with Examples	234
Power Required by Cotton Machinery	238
Belting Required for Various Machines	240
Horse-power Tables of Shafting	242
Horse-power Tables of Belting	246
Data on Manila Transmission Rope	250
Spindles in U. S.	252
World's Cotton Spindles	253

{7}

OPENING AND PICKING MACHINERY.

The Opening and Picking of cotton should have the same careful attention as the Carding and Spinning, although the latter processes may seem to some to be more important. Much more attention is being given to this Department everywhere to-day than formerly, and better equipments of machinery are being used. The same equipment is not equally good for all classes of work, as the machinery must be designed and adjusted for the particular kind of stock to be used.

Unless the cotton is well opened and cleaned, and good even laps are made, the Carding will suffer, and the Card Clothing will soon be damaged, which means poor and costly work.

We invite with every confidence all possible investigation into the construction and improved design of our Opening and Picking machinery, and the work it is doing in the mills. This entire line of machinery is substantially built, very simple, and contains many valuable improvements.

{8}

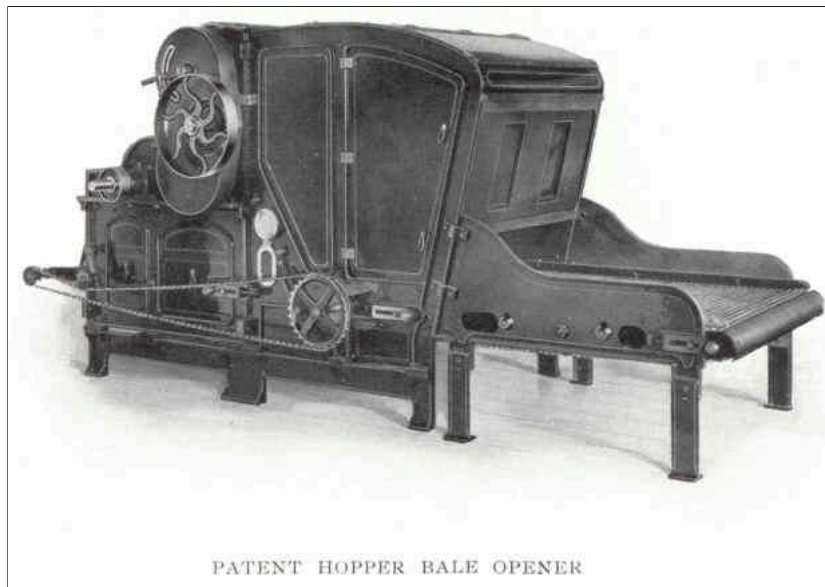

PATENT HOPPER BALE OPENER

{9}

HOPPER BALE OPENER.

An investigation of the present methods of handling cotton before it reaches the Pickers shows that in a large percentage of mills there are opportunities for greatly reducing the labor cost and at the same time improving in a marked degree the quality of opening and mixing. The saving which can be effected in labor, and the better results obtained by a more thorough opening of the cotton and a more even mixing, can hardly be appreciated except by those who have seen it demonstrated by the use of our Hopper Bale Opener.

This machine is extensively used in England and on the Continent, where it is giving most satisfactory results. It is filling a need which has long existed.

LABOR SAVING—A bale of cotton can be thoroughly opened *without damage to the staple* in six to ten minutes, which means that one hand can open upwards of 150,000 to 200,000 lbs. per week and still have time for taking care of bagging, ties, etc. Even when the weekly consumption of cotton is very much less than this there is a saving in labor, as the quick completion of the work means that the attendant can give his attention to something else.

QUALITY OF WORK—The fluffy condition of the cotton as it is delivered from the Hopper Bale Opener shows the very thorough manner in which it is opened. Although the cotton is fed to the machine in large matted sections taken directly from the bales as they lie around the horizontal feeding apron, no bunches come through. When cotton is opened

and mixed by hand the result is not what is generally supposed. The stock is still in large bunches and matted to such an extent that when fed into the Hoppers of ordinary Openers it is impossible to obtain an even or thorough mixing.

{10}

THE FEEDING APRON of the Hopper Bale Opener usually extends four feet back of the Hopper which enables the operator to group a number of bales around the machine so as to take cotton first from one and then from another. This gives an even mixing of the stock from the various bales. If it is desired this idea can be carried still further by making the Feeding Apron longer, so as to allow of taking cotton from a greater number of bales.

METHOD OF WORKING—The matted sections taken direct from the bale and placed on the slowly driven Horizontal Feeding Apron move forward into the Hopper and are taken by the more rapidly moving Spiked Elevating Apron, which subjects the cotton to a sort of combing action. At the top of this Apron there is a spiked Cylinder which further combs the cotton and throws back into the Hopper any unopened pieces. A Stripping Beater with stiff leather blades strips the stock from the Spiked Apron and delivers it onto the short delivery Apron at the front of the machine.

DELIVERY ARRANGEMENTS—The ordinary or standard delivery arrangement is shown in the cut, [page 8](#), and in the outline drawing, [page 12](#). We have recently designed a double apron delivery for use with Condenser and Blower systems, where the cotton has to be carried quite a distance. This arrangement does away with the necessity of passing the stock through a fan and is approved by the Insurance Companies.

The cotton being delivered into the conveying pipe ahead of the "Blower Fan," there is no fire risk due to hard substances passing through or stock getting caught in the fan. We have designed many special delivery arrangements to meet the various conditions which present themselves, including a suitable delivery for use with either lattice distributing systems or blowing systems.

{11}

DISTRIBUTING SYSTEMS—The installation of this Hopper Bale Opener makes a distributing system more advantageous and satisfactory. We have equipped many Opening Rooms with Distributing Lattices which deliver the cotton directly into the Hoppers of the Self-feeding Openers, thus saving another handling.

When the Hopper Bale Opener is located some distance from the distributing lattice, the latter may be fed by a blower and condenser system, and when the distance is very short an elevating lattice is used, dropping the cotton directly on the distributing lattice. We are always glad to take up special cases and make recommendations in connection with the conveying and distribution of cotton either for short or long distances.

An advantage which is not usually thought of or appreciated is the more even Breaker laps obtained where a Hopper Bale Opener and distributing system are used. The Hoppers of the Feeders are more evenly fed and the stock is in a much better condition than when mixed and fed by hand.

CONSTRUCTION—The machine is very strongly built throughout. An extra large Hopper is an advantage possessed by this Opener. The Spiked Elevating Lattice is made on a new patented system and the slats on same are of heavy selected stock.

DRIVING PULLEYS AND SPEEDS—The Driving Pulleys are on the right hand side when facing the Hopper or Feed and are 11 in. dia., 3 in. face, tight and loose, and should be driven at about 582 revs. per minute.

PRODUCTION—150,000 to 200,000 lbs. per week of 60 hours.

FLOOR SPACE—The machine with short Feeding Lattice, as shown on the illustration, [page 8](#), is 13 ft. 1-1/4 in. x 6 ft. 10 in.

{12}

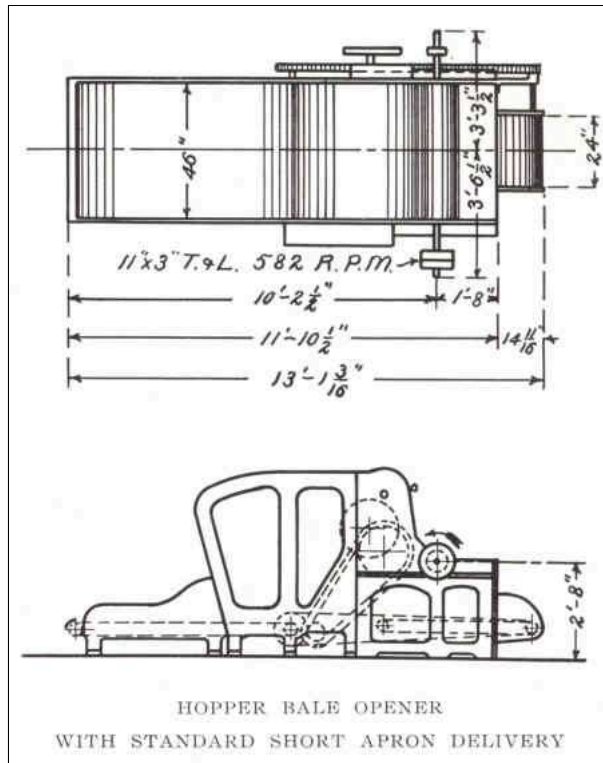

**HOPPER BALE OPENER
WITH STANDARD SHORT APRON DELIVERY**

{13}

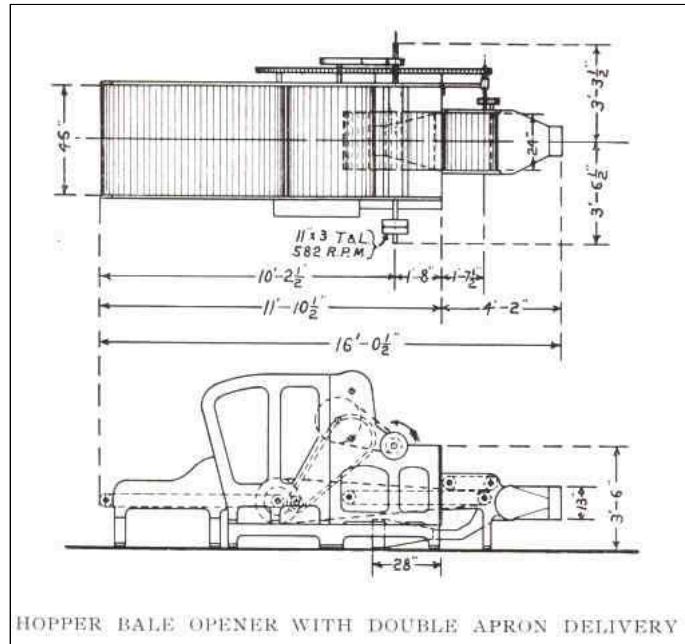

HOPPER BALE OPENER WITH DOUBLE APRON DELIVERY

{14}

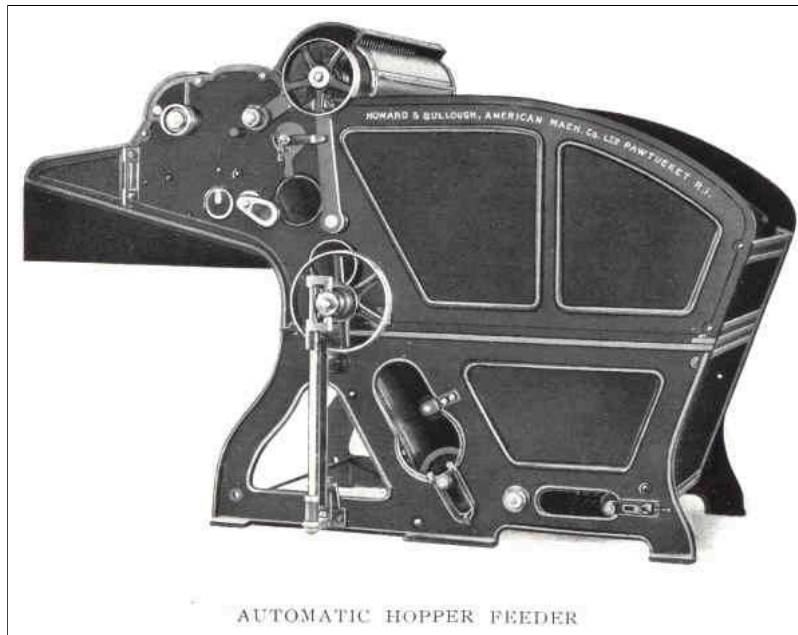

AUTOMATIC HOPPER FEEDER

{15}

AUTOMATIC HOPPER FEEDER.

HOPPER—This is extra large and capable of holding 400 to 450 pounds of cotton.

SPIKED ELEVATING APRON runs over large flanged blocks and is extra strong.

STRIPPING COMB OR ROLLER—This works in conjunction with the Spiked Apron, and is very simple and durable. It is self-cleaning and is easily adjusted by means of a handle on one side of the machine. This handle can be locked in position after an adjustment is made, and the arrangement, although operated from one side of the Feeder, gives a positive parallel motion, and consequently a true setting of the Stripping Comb.

PIN BEATER takes the cotton from the Spiked Apron. The stock, after passing over the cleaning grids, drops on the Delivery Apron.

KNOCK-OFF ARRANGEMENT—This is simple and durable, and is so designed as to be easily connected to the knock-off on the Breaker Lapper or other machine which follows.

APRONS all have strong and easily adjusted tightening devices.

SIMPLICITY—Our Feeder is reduced to the simplest design possible consistent with even and good work, and has no troublesome cone drums.

COMBINATIONS of this Feeder with the various Opening and Picking Machines are made to suit any special requirements of the mill. The Feeder when combined with an Opener is driven from a pulley on the Cylinder or Beater shaft, and when feeding on to the Apron of a Lapper is driven from the Lapper Countershaft.

DRIVING PULLEY AND SPEED—The Driving Pulley is 10 in. dia., 2-1/4-in. face, and should be driven at about 550 revs. per minute.

FLOOR SPACE—Length, 10 ft. 5 in.; width, 5 ft. 6 in.

FLOOR PLAN AND ELEVATION—See [page 52](#).

{16}

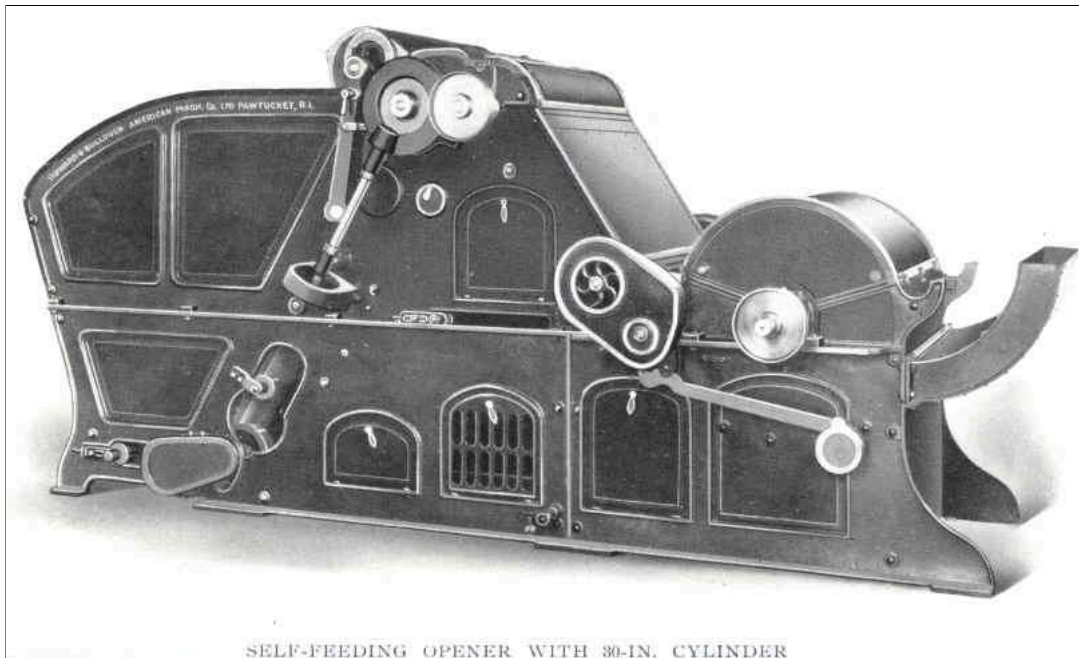

SELF-FEEDING OPENER WITH 30-IN. CYLINDER
 SELF-FEEDING OPENER WITH 30-IN. CYLINDER

{17}

SELF-FEEDING OPENER.

This is a combination of the Automatic Hopper Feeder with an Opener Section built as one machine. The Beater in the Opener Section may be a two-blade rigid Beater, 18 in. dia., or a 30-in. dia. Special Cylinder, which is shown and described on [page 18](#).

This machine may be arranged for trunking connections, as shown in the cut on the [opposite page](#), or it may be attached directly to a Breaker Lapper, forming a Combined Self-feeding Opener and Breaker Lapper (see [page 30](#) for cut of this machine).

DRIVING PULLEY—Self-feeding Opener with 18 in. Beater, 9 in. dia., 4-1/4 in. face; with 30-in. Cylinder, 16 in. dia., 4-1/4 in. face. Other sizes can be furnished.

SPEEDS—1,450 revs. per minute for 18-in. Beater and 550 revs. per minute for 30-in. Cylinder when running with ordinary cotton. For long staple cottons the Beater speed is reduced to 800 to 1,050 revs. per minute and the Cylinder speed to 300 to 450 revs. per minute.

PRODUCTION—See Breaker Lappers.

FLOOR PLANS AND ELEVATIONS— See [pages 56](#) and [57](#).

{18}

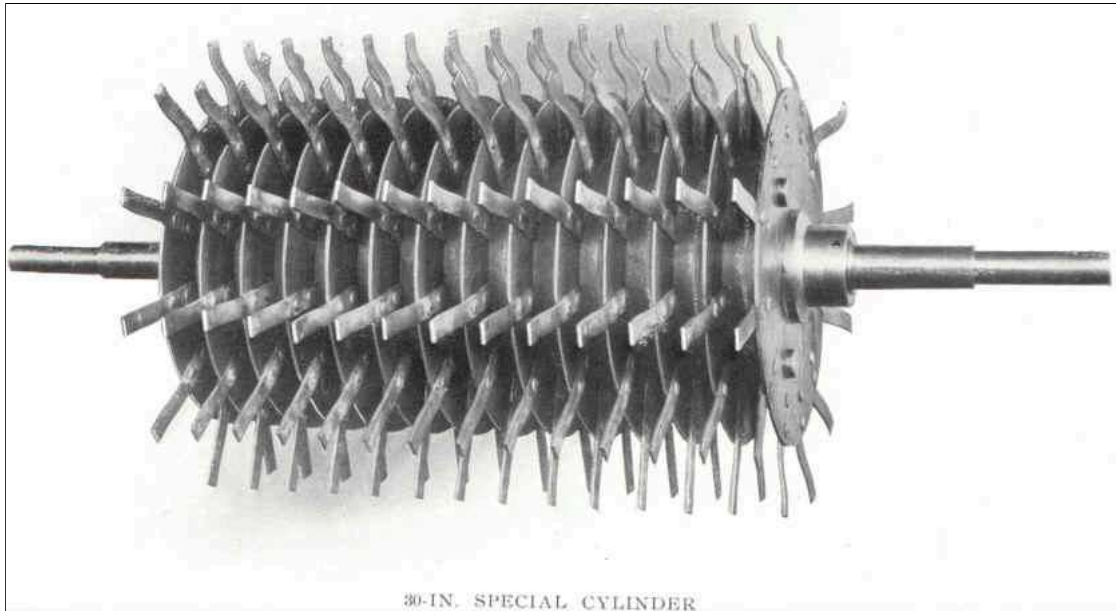

30-IN. SPECIAL CYLINDER
30-IN. SPECIAL CYLINDER

{19}

30-INCH SPECIAL CYLINDER.

This 30-inch Cylinder is specially designed for use in Self-Feeding Openers where these machines are arranged for trunk connection or combined with Breaker Lappers.

The large diameter makes it possible to use more grid bars than with the blade beaters. The main points considered in the design of this 30-inch cylinder were, more thorough opening of the cotton, greater production without injury to the staple, and better cleaning.

These Cylinders are made from steel boiler plates, and the steel fingers are fastened on by rivets. These fingers are so arranged that in one revolution they strike all points along the entire width of the feed rolls. In case of accident to fingers, caused by some hard substance getting into the machine, the damaged fingers can be easily replaced.

We have adopted the 30-inch Special Cylinder, believing it to be preferable to those of larger diameter.

{20}

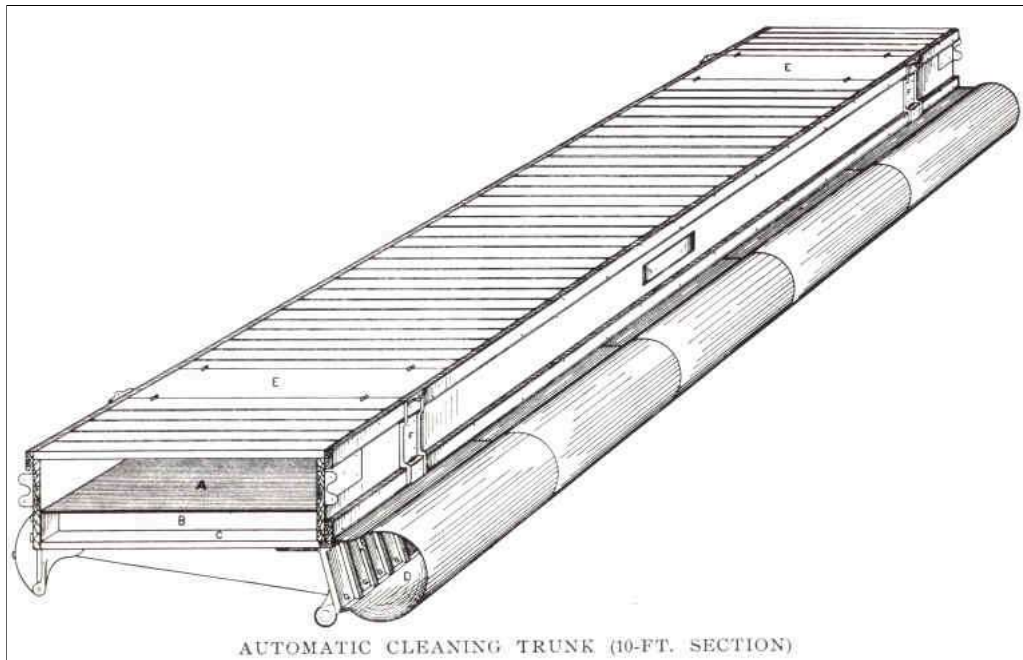

AUTOMATIC CLEANING TRUNK (10-FT. SECTION)
 AUTOMATIC CLEANING TRUNK (10-FT. SECTION)

{21}

CLEANING TRUNK.

On the [opposite page](#) is shown a 10-ft. section of Automatic Cleaning Trunk. It is usual to install two of these sections, making 20 ft., and to suspend same from the ceiling.

The cotton passes over Transverse Grids A and the leaf and dirt drop between the Grids into a series of compartments B, which are automatically cleaned out by air draft from a Fan. Each compartment has a hinged door or bottom C, which when dropped leaves an opening into the exhaust air pipe D. The hinged doors are dropped one at a time, and the openings are shown at G.

The Fan is connected to the exhaust air pipe D, and is only running while the Trunk is being cleaned.

The removable doors E give access to the top of the Trunk, and the brackets F are for the supporting rods.

One of the advantages of this Trunk is that it can be hung from the ceiling out of the way and not occupy valuable floor space. It is carefully built and the joints of the doors are covered with leather to prevent leaks.

[Page 59](#) shows a system where 20 ft. of Automatic Cleaning Trunk is used together with the necessary Conducting Trunk; the Opener being on the first floor and the Breaker Lapper with Gauge Box and Condenser on the second.

{22}

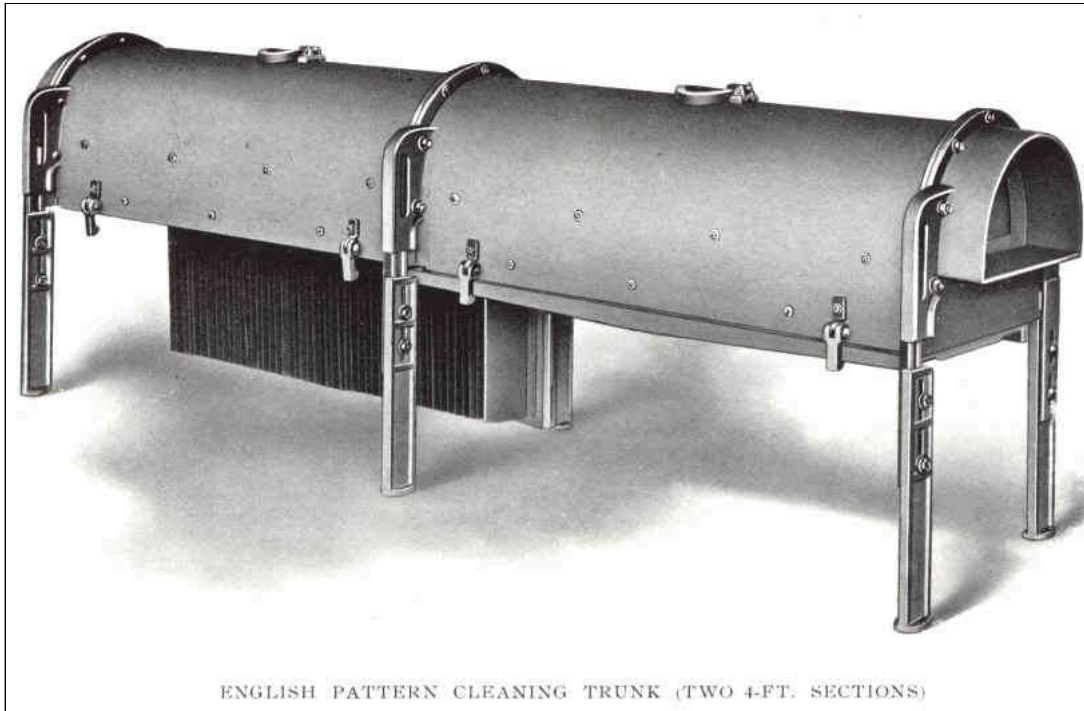

ENGLISH PATTERN CLEANING TRUNK (TWO 4-FT. SECTIONS)
 ENGLISH PATTERN CLEANING TRUNK (TWO 4-FT. SECTIONS)

{23}

Cleaning Trunk is of special advantage to mills using low grade stock. All cotton contains more or less light dirt and leaf, which it is difficult to entirely remove in the Lappers, on account of the fan draft essential to the formation of a good sheet on the screens carrying some of the lighter impurities along with the cotton. The passing of the stock over the transverse Grids in the Cleaning Trunk at a low velocity provides an efficient means for removing this dirt and leaf.

We also build an *English pattern Trunk*, which is shown in the illustration on [page 22](#). This Trunk is supported by stands which rest on the floor, and is built in 4-ft. sections, several of these being coupled together. Although not automatic, it is easily cleaned by dropping the doors which cover the entire bottom of the Trunk and carry the Grids. In the illustration one of these doors is shown down, and the sheet iron Grids are plainly visible.

{24}

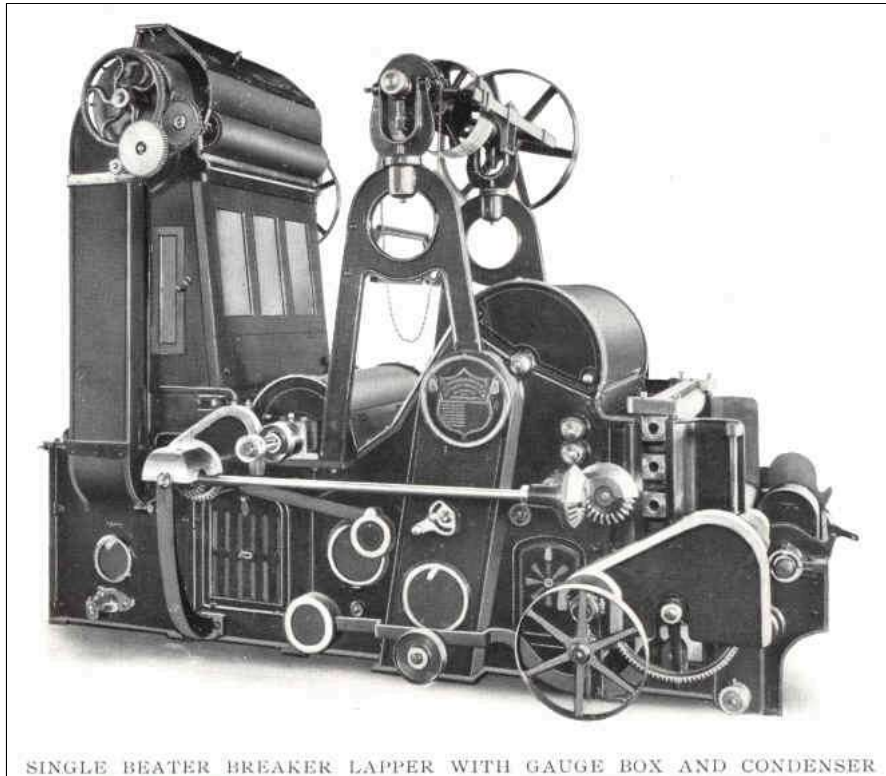

SINGLE BEATER BREAKER LAPPER WITH GAUGE BOX AND CONDENSER

SINGLE BEATER BREAKER LAPPER WITH GAUGE BOX AND CONDENSER

{25}

BREAKER LAPPERS.

On [page 24](#) is shown our Single Beater Breaker Lapper with Gauge Box and Condenser, and on [page 28](#) the same machine with a Cage Section.

GAUGE BOX AND CONDENSER—We strongly recommend the use of Gauge Boxes and Condensers when the Breaker Lappers and Openers are on different floors, or the stock has to be carried any distance. Under these conditions there is a considerable quantity of cotton passing between the Opener and Lapper, which on account of the stopping and starting of the latter is liable to make thick and thin places in the lap.

The use of the Condenser and Gauge Box overcomes this difficulty as the cotton is received under these varying conditions and the Gauge Box acts as an Evener and delivers a uniform supply to the Feed Rolls behind the Beater. When the connection between the Opener and Breaker Lapper is short the Cage Section can be used without difficulty.

The Condenser Fan, which is of extra large size, is conveniently placed under the Gauge Box and Condenser Section. The Gauge Box has glass panels on the two sides and front, so that the cotton can be seen and the feed regulated.

BEATERS—Although the cuts show Single Beater machines, we build them with two Beaters if required or with one Cylinder and one Beater.

IMPROVED CALENDER HEAD—Our Lappers have many valuable special features, including our improved Calender Head, which allows the machine to be stopped by the Drop Handle without breaking the lap. When the lap is of the required length and the machine knocks off, the large Lap Rolls as well as the Calender Rolls, Feed Apron and Cages stop, and the lap is not broken.

If the lap continues to revolve after the machine has knocked off, it becomes sticky and there is likely to be trouble from split laps back of the Cards. *Our arrangement prevents this and also enables the machine to be stopped at any time during the formation of a lap without breaking the lap.*

{26}

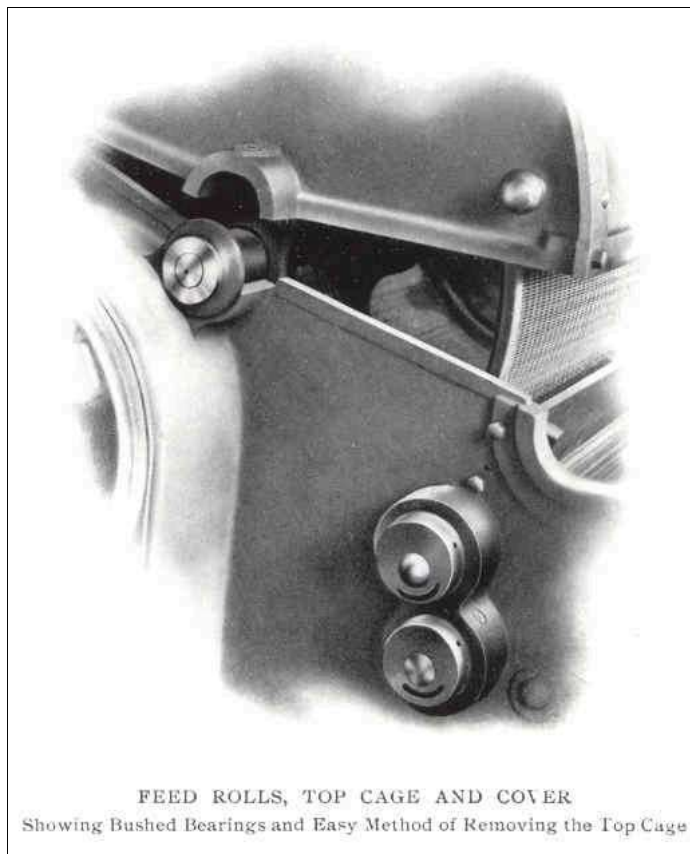

FEED ROLLS, TOP CAGE AND COVER
Showing Bushed Bearings and Easy Method of Removing the Top Cage

FEED ROLLS, TOP CAGE AND COVER
Showing Bushed Bearings and Easy Method of Removing the Top Cage

{27}

GEARS EASILY REMOVED—All the large gears are fastened by an improved method. Instead of driving them onto keys, which makes their removal difficult, we use with each large gear a square key let into the shaft, and two set screws. The gears fit the keys, but not tightly enough to prevent their easy removal after loosening the set screws.

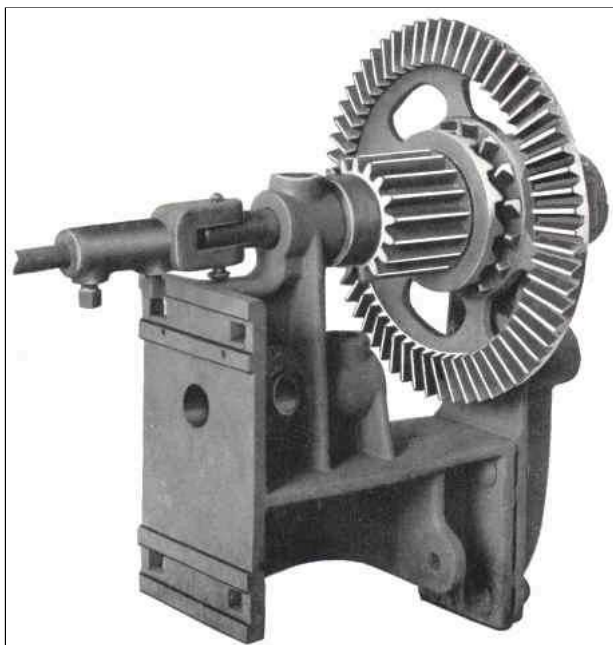

CLUTCH GEARS—The Calender Rolls are stopped and started by large Clutch Gears which are a great improvement over the common Drop Shaft and Gear. With this method the starting strain is distributed over all the teeth in the Clutch

Gears, entirely doing away with the frequent breakages under the old system.

BEARINGS—Where it is possible the bearings are made in bush form, as shown in cut [page 26](#), thus reducing to a minimum the time taken to make replacements and the cost of same. Our bearings are very easy to adjust, and their special form prevents oil from getting to the inside of the machine. All high speed Shafts, viz., Fan, Side and Beater Shafts, have ring oiling bearings.

{28}

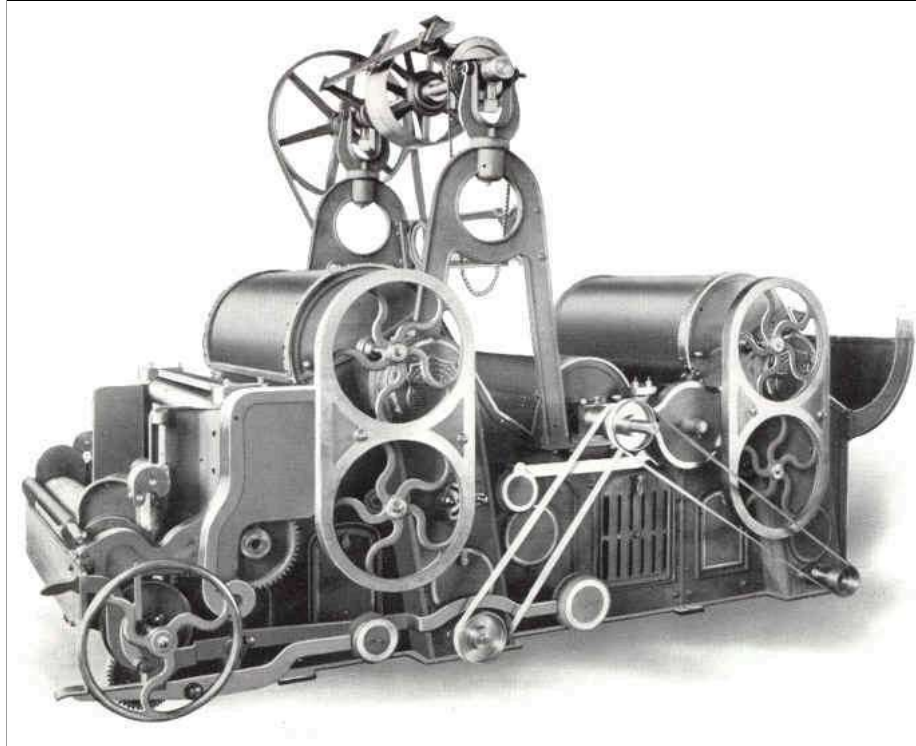

{29}

TOP CAGES AND COVERS—The Top Cages of our Lappers are easily removed, as will be seen by referring to the cut, [page 26](#). The sides of the cage cover or bonnet fit snugly over the bushed bearings. To remove the cage or bushings, it is only necessary to turn back the cover. These covers are all made with oil holes directly over the bearing, so it is not necessary to raise the cover for the purpose of oiling.

NO TILTING OF LAP RACKS—The Lap Racks slide up and down on steel shafts, which entirely prevent the tilting of the Racks and consequent breakages.

SHAFTS—Our Beater and Fan shafts are made from a very hard iron specially mixed to give long life to these high speed shafts.

A countershaft complete with pulleys is attached to each Lapper.

DRIVING PULLEYS—One-beater Breaker Lappers 16 in. dia., 4-1/4 in. face, T. & L.

Two-beater Breaker Lappers or One-beater Breaker Lappers with extra Cage Section or Condenser and Gauge Box Section 16 in. dia., 5-1/4 in. face, T. & L.

In combinations which have 3 beaters to be driven from one countershaft of machine, 16 in. dia., 6-1/4 in. face, T. & L.

Other sizes can be furnished.

SPEEDS—The usual speed of all lapper countershafts is 435 revs. per minute, which gives 1,450 revs. per minute of the Beaters, and 550 revs. per minute of Cylinders, for ordinary cotton. For long staple cottons the beater speed is reduced to 800 to 1,050 revs. per minute and the Cylinder speed to 300 to 450 revs. per minute.

PRODUCTION—On ordinary cotton 15,000 to 20,000 lbs. per week of 60 hours. In some cases the production is far in excess of these figures. For long staple cottons, 10,000 to 15,000 lbs.

See production table, [page 36](#).

FLOOR PLANS AND ELEVATIONS—See [pages 54 to 57](#). These plans are for 40-in. or 41-in. machines, and 45-in. machines are 4 in. wider.

{30}

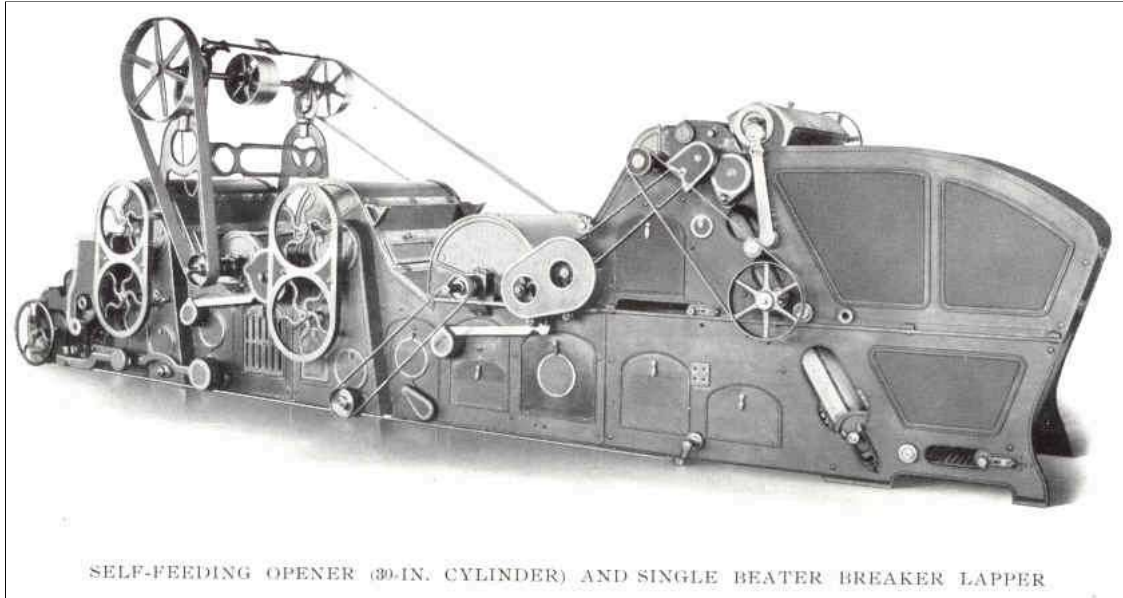

SELF-FEEDING OPENER (30-IN. CYLINDER) AND SINGLE BEATER BREAKER LAPPER

SELF-FEEDING OPENER (30-IN. CYLINDER) AND SINGLE BEATER BREAKER LAPPER

{31}

COMBINATION MACHINES.

On the opposite page is shown a Self-feeding Opener with 30-in. Cylinder combined with a Single Beater Breaker Lapper. This is a very popular combination and, it will be noted, is built as one straight machine. A floor plan and elevation are shown on [page 54](#). This same combination with an 18-in. Beater instead of the 30-in. Cylinder in the Opener Section is shown in plan and elevation on [page 55](#).

We also build a Self-feeding Opener with Cage Section and Calender Head, which is well adapted to work Egyptian and Sea Island cottons. (See [page 53](#) for plan and elevation.)

Self-feeding Openers when built as separate machines can be placed on any floor above or below the Breaker Lappers, or on the same floor, the connections being made by Automatic Cleaning Trunks, Conducting Trunks, and galvanized iron pipe, as the conditions may require.

On [pages 56 and 57](#) we show Single Beater Breaker Lappers with Gauge Boxes and Condensers connected to Self-feeding Openers by short sections of Conducting Trunk. The Breakers are on the floor above the Openers. One drawing shows the Self-feeding Opener with 18-in. Beater, and the other with 30-in. Cylinder.

{32}

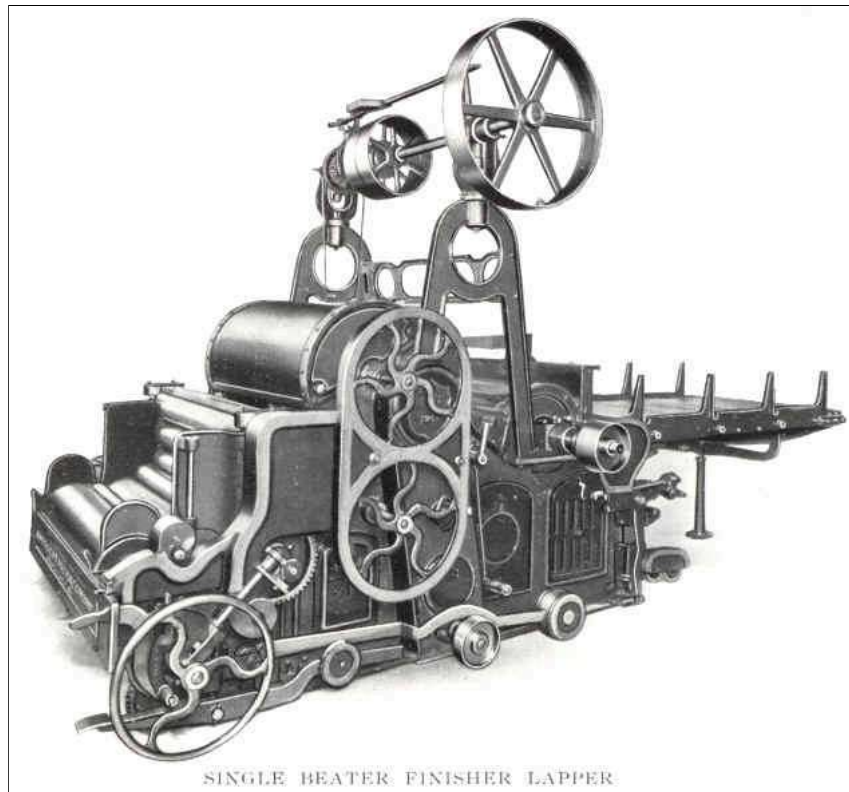

SINGLE BEATER FINISHER LAPPER

SINGLE BEATER FINISHER LAPPER

{33}

INTERMEDIATE AND FINISHER LAPPERS.

These machines have our improved Calender Head, which has already been described in connection with Breaker Lappers. Each machine has a countershaft and pulleys complete with stands as shown.

BEATER BOXES—All our beater boxes are fixed and our feed rolls adjustable, which we consider superior to having the beaters adjustable. After thorough investigation and long practice we have found that adjustable beaters are liable to get out of line, causing them to heat and wear quickly.

DRAFT REGULATION—The air chamber from fan to cage section on each side of the machine is supplied with a damper, operated from the outside of the machine. With this arrangement the air can be drawn through the top and bottom cages in any desired proportion, and the operator can regulate the drafts to give the best results.

BEATERS—Two-blade (18 in. dia.) beaters are mostly used, but we furnish the Houghton patent beater with corrugated teeth, or carding beaters, when specified.

OUTSIDE HANDLES FOR DUST DOORS—We have recently added handles on the outside of the machine for dropping the cut-off board under the grids. The dirt and leaf which collect on this board are liable to fill up the grids if not regularly removed. The outside handles make the dropping of the cut-off boards very convenient and much reduce the liability of neglect on the part of the attendant.

DRIVING PULLEYS

One-beater machines, 16 in. dia., 4-1/4 in. face, T. & L.

Two-beater machines, 16 in. dia., 5-1/4 in. face, T. & L. Other sizes can be furnished.

SPEEDS—The usual speed of countershafts is 435 revs. per minute, which gives 1,450 revs. of the two-blade beaters and 1,063 revs. of carding beaters. For long staple cottons the beater speed is reduced to 800 to 1,050 revs. per minute.

PRODUCTION—On ordinary cotton 12,000 to 15,000 pounds per week of sixty hours. These productions are often exceeded. For long staple cottons, 8,000 to 10,000 pounds. For production table, see [page 37](#).

FLOOR PLANS AND ELEVATIONS— See [page 58](#) for floor plan of 40-inch one-beater Intermediate or Finisher Lapper. 45-inch machines are 4 inches wider.

{34}

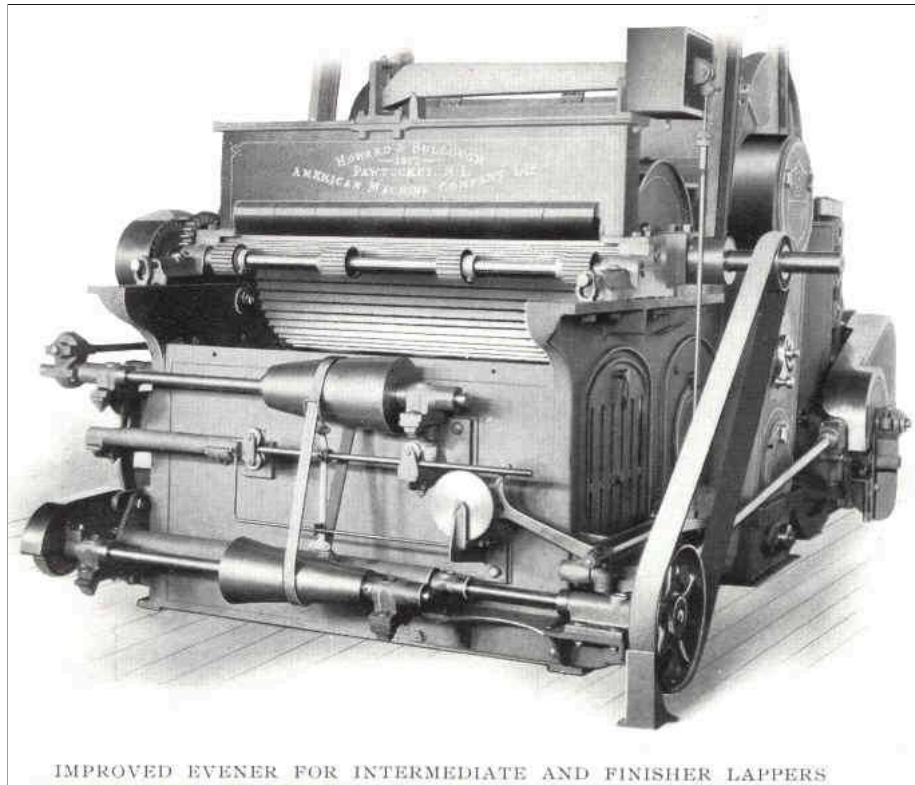

IMPROVED EVENER FOR INTERMEDIATE AND FINISHER LAPPERS

{35}

IMPROVED EVENER.

The obtaining of even laps is a matter of prime importance. The demand for more perfect work has emphasized the need for better picking, and for laps which are even not only in total weight, but throughout. Our improved design fills the following essential qualifications of a good Evener.

1st—Sensitiveness and prompt action, so that any variation in the weight passing under the Evener Plates will be taken care of immediately.

2d—Steadiness of running and action, so that there is no tendency to "hunt," *i. e.*, the cone belt will at once take its new position without traveling up and down.

3d—Simplicity and few moving parts.

4th—Small amount of attention required.

The direct method of communicating any movement of the Evener Plates to the cone belt, the multiplication of this movement and the short cones are features which help to secure sensitiveness and prompt action.

The small amount of lost motion between the Evener Plates and the cone belt, and the free movement of the belt shipper rod, which runs on rollers, make the action positive and steady.

The cut on [page 34](#) shows our Evener and indicates the simplicity of same. The number of moving parts has been reduced to a minimum. The Evener Plates and feed roll give great cleaning capacity on account of the bite of the Plates being

close to the Beater. The Evener Plates are on top of a 3-in. dia. steel feed roll, which gives a very rigid support and ensures all the variation in the thickness of the cotton under the plates being communicated to the Evener belt.

The cones are conveniently placed under the feeding apron, and the lower cone runs in an adjustable cradle which allows the belt to be made endless and keeps it at an even tension at all times.

{36}

BREAKER LAPPER.

PRODUCTION IN POUNDS PER TEN HOURS

Dia. of Feed Pulley In.	Rev. per Min. of 9-in. Calendar Roll	Weight of Lap in Ounces per Yard							
		10	10½	11	11½	12	12½	13	13½
3	4.153	1100	1160	1210	1270	1320	1380	1430	1490
3½	4.845	1280	1350	1410	1480	1540	1610	1670	1730
4	5.537	1470	1540	1610	1690	1760	1830	1910	1980
4½	6.229	1650	1730	1820	1900	1980	2060	2150	2230
5	6.921	1830	1930	2020	2110	2200	2290	2390	2480
5½	7.613	2020	2120	2220	2320	2420	2520	2620	2720
6	8.305	2200	2310	2420	2530	2640	2750	2860	2970
6½	8.997	2390	2500	2620	2740	2860	2980	3100	3220
7	9.689	2570	2700	2830	2950	3080	3210	3340	3470
7½	10.382	2750	2890	3030	3170	3300	3440	3580	3720
8	11.074	2940	3080	3230	3380	3520	3670	3820	3960
		14	14½	15	15½	16	16½	17	18
3	4.153	1540	1600	1650	1710	1760	1820	1870	1930
3½	4.845	1800	1860	1930	1990	2060	2120	2180	2240
4	5.537	2060	2130	2200	2280	2350	2420	2500	2640
4½	6.229	2310	2390	2480	2560	2640	2720	2810	2970
5	6.921	2570	2660	2750	2840	2940	3030	3120	3300
5½	7.613	2830	2930	3030	3130	3230	3330	3430	3630
6	8.305	3080	3190	3300	3410	3520	3630	3740	3960
6½	8.997	3340	3460	3580	3700	3820	3940	4060	4290
7	9.689	3600	3730	3850	3980	4110	4240	4370	4620
7½	10.382	3850	3990	4130	4270	4400	4540	4680	4950
8	11.074	4110	4260	4400	4550	4700	4840	4990	5280

NOTE—Ten per cent. has been deducted in the above table for stops, etc. 1,450 revolutions per minute of beater.

{37}

INTERMEDIATE AND FINISHER LAPPER.

PRODUCTION IN POUNDS PER TEN HOURS

Dia. of Feed Pulleys In.	Rev. per Min. of 9-in. Calendar Roll	Weight of Lap in Ounces per Yard								
		8	8½	9	9½	10	10½	11	11½	
3	4.360	920	980	1040	1100	1160	1210	1270	1330	
3½	5.087	1080	1150	1210	1280	1350	1420	1480	1550	
4	5.814	1230	1310	1390	1460	1540	1620	1700	1770	
4½	6.540	1390	1470	1560	1650	1730	1820	1910	1990	
5	7.267	1540	1640	1730	1830	1930	2020	2120	2210	
5½	7.994	1690	1800	1910	2010	2120	2220	2330	2440	
6	8.720	1850	1960	2080	2200	2310	2430	2540	2650	
6½	9.447	2000	2130	2250	2380	2500	2630	2750	2880	
7	10.174	2160	2290	2430	2560	2700	2830	2970	3100	
7½	10.900	2310	2450	2600	2740	2890	3030	3180	3320	
8	11.627	2470	2620	2770	2930	3080	3240	3390	3540	
		12	12½	13	13½	14	14½	15	16	
3	4.360	1390	1440	1500	1560	1620	1680	1730	1850	
3½	5.087	1620	1690	1750	1820	1890	1960	2020	2160	
4	5.814	1850	1930	2000	2080	2160	2230	2310	2460	
4½	6.540	2080	2170	2250	2340	2430	2510	2600	2770	
5	7.267	2310	2410	2500	2600	2700	2790	2890	3080	
5½	7.994	2540	2650	2750	2860	2970	3070	3180	3390	
6	8.720	2770	2890	3000	3120	3240	3350	3470	3700	
6½	9.447	3000	3130	3250	3380	3500	3630	3750	4010	
7	10.174	3240	3370	3510	3640	3780	3910	4040	4310	
7½	10.900	3470	3610	3750	3900	4040	4190	4330	4620	
8	11.627	3700	3850	4010	4160	4310	4470	4620	4930	

NOTE—Ten per cent. has been deducted in the above table for stops, etc. 1,450 revolutions per minute of beater.

{38}

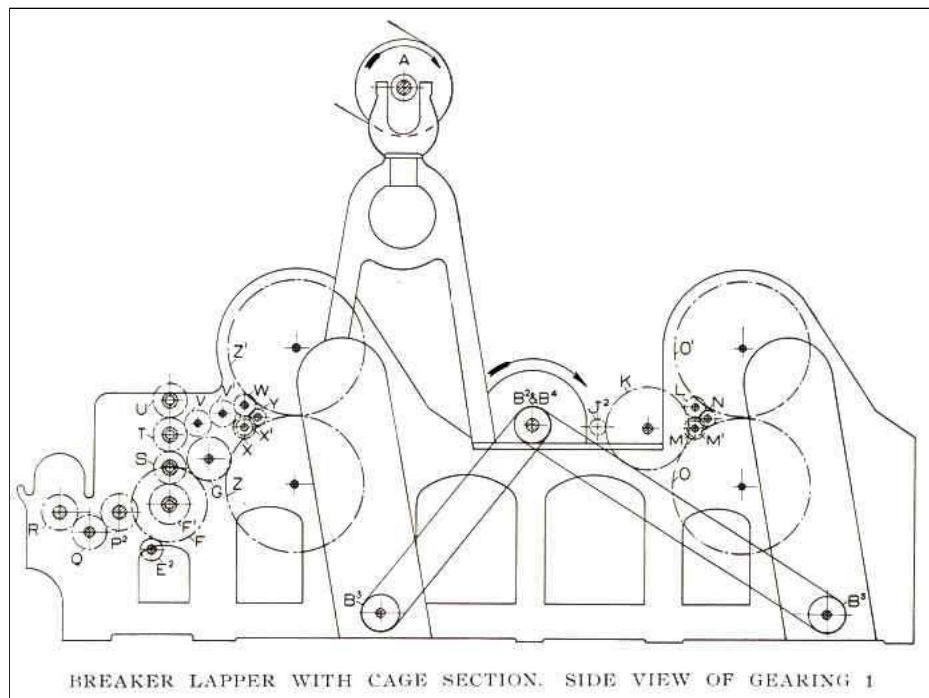

BREAKER LAPPER WITH CAGE SECTION. SIDE VIEW OF GEARING 1

BREAKER LAPPER WITH CAGE SECTION.
SIDE VIEW OF GEARING 1

{39}

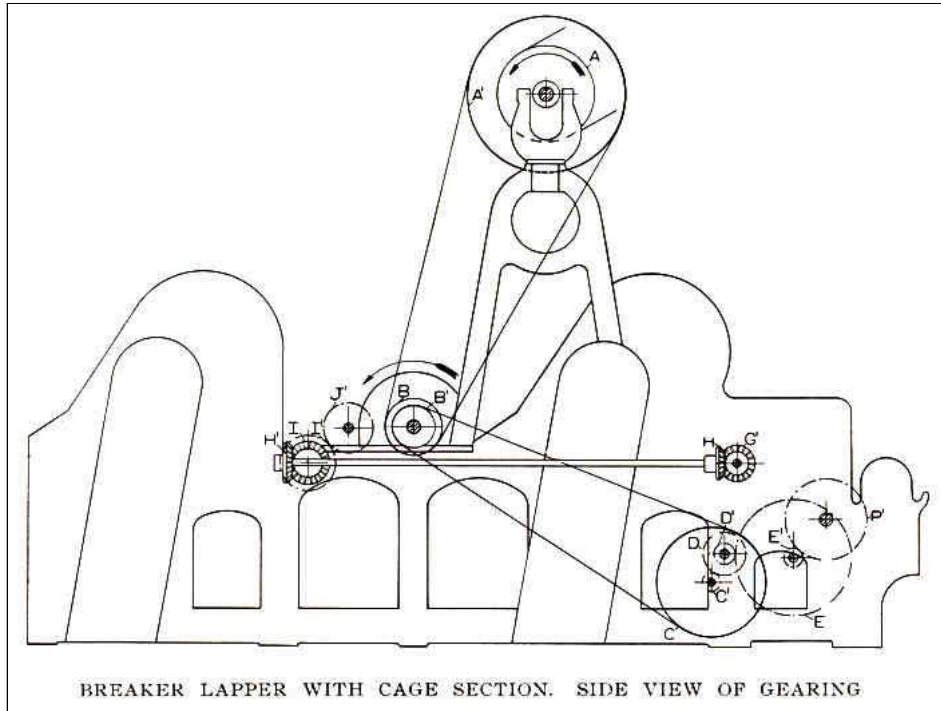

BREAKER LAPPER WITH CAGE SECTION. SIDE VIEW OF GEARING

BREAKER LAPPER WITH CAGE SECTION,
SIDE VIEW OF GEARING

{40}

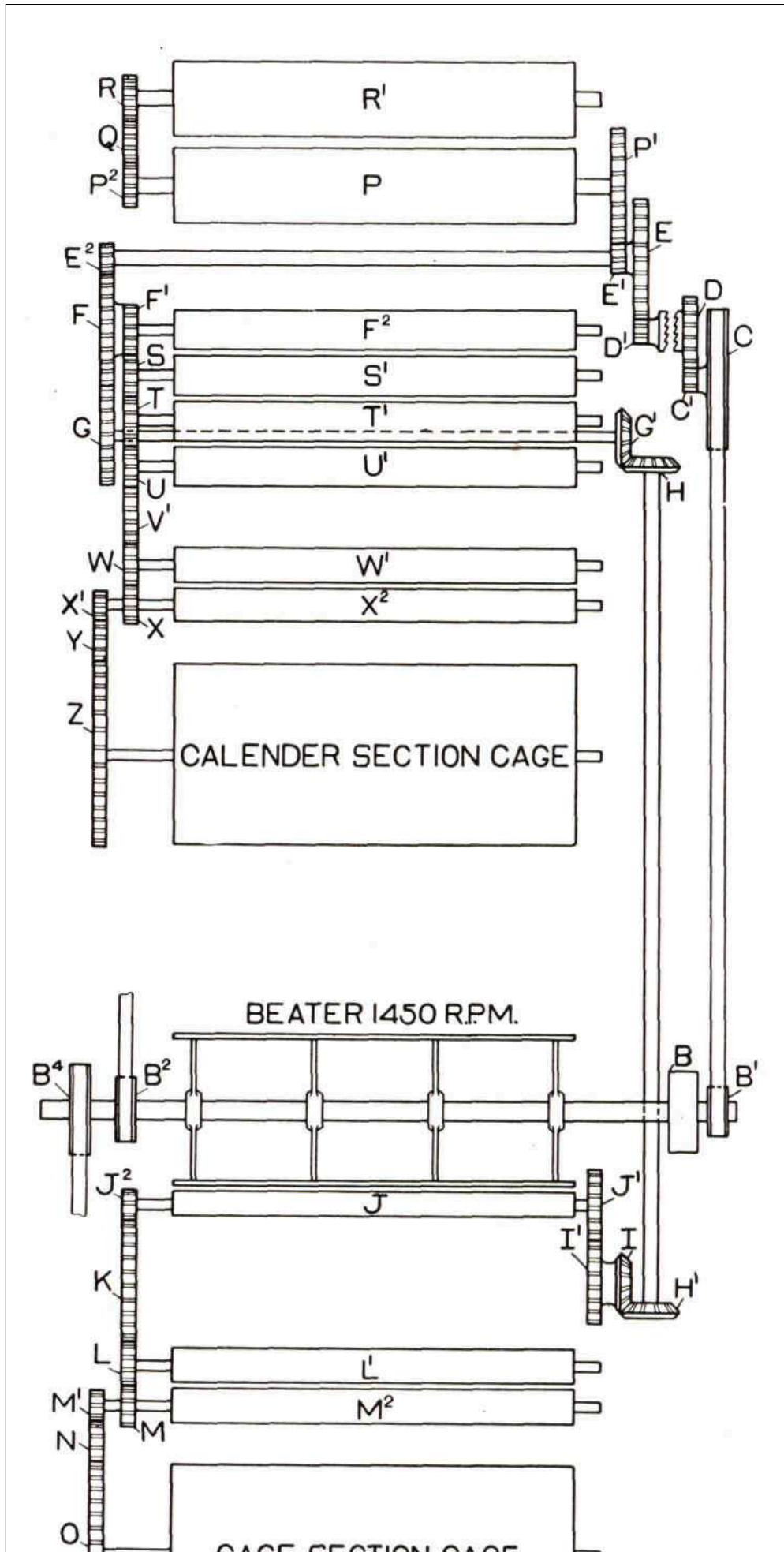

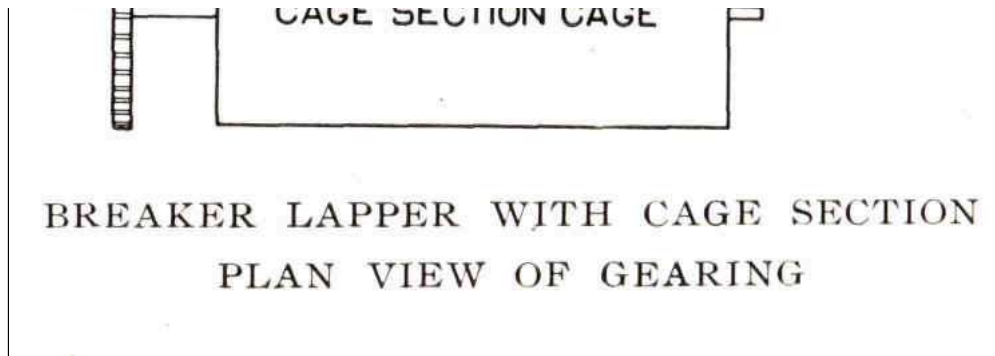

BREAKER LAPPER WITH CAGE SECTION
PLAN VIEW OF GEARING

{41}

BREAKER LAPPER.

ALPHABETICAL REFERENCES TO DRAWINGS.

- A Main Driving Pulley, 16 in. dia. x 4-1/4 in. face; 5-1/4 in. face for Two-beater Machine.
- A¹ Beater Driving Pulley, 30 in. dia. x 4-1/4 in. face.
- B Beater Pulley, 9 in. dia. x 4-1/4 face (occasionally 10 in. dia.)
- B¹ Feed Pulley, 3 in. to 13 in. dia. x 2-1/4 in. face; advancing by 1/2 in. increments.
- B² Calender Section Fan Driving Pulley, 6 in. dia. x 2-1/4 in. face.
- B³ Calender Fan Pulley, 8 in. dia. x 2-1/4 in. face.
- B⁴ Cage Section Fan Driving Pulley, 6 in. dia. x 2-1/4 face for Straight Machine or direct connected Opener and Breaker Lapper. If with Trunking Connection, B⁴ is 8 in. dia. and B⁵ is 6 in. dia., to give higher speed of Fan.
- B⁵ Cage Fan Pulley, 8 in. dia. x 2-1/4 in. face for Straight Machine or direct connected Opener and Breaker Lapper. If with Trunking Connection, B⁴ is 8 in. dia. and B⁵ is 6 in. dia., to give higher speed of Fan.
- C Driving Pulley for Bottom Cross Shaft, etc., 18 in. dia. x 2-1/4 in. face.
- C¹ Clutch Driving Gear, 15 T.
- D Large Clutch Gear, 35 T.
- D¹ Small Clutch Gear, or Bottom Shaft Driving Gear, 17 T.
- E Bottom Cross Shaft Driven Gear, 96 T.
- E¹ Front Lap Calender Roll Driving Gear, 12 T.
- E² Bottom Cross Shaft Gear, driving Calender Rolls and Top Cross Shaft, 14 T.
- F Large Double Intermediate, driving Top Cross Shaft, 50 T.
- F¹ Small Double Intermediate, driving Bottom Calender Roll, 27 T.
- F² Bottom Calender Roll, 7 in. dia.
- G Top Cross Shaft Gear, 30 T.
- G¹ Side Shaft Driving Bevel Gear, 24 T.
- H Side Shaft Bevel Gear, Calender End, 24 T.

- H¹ Side Shaft Bevel Gear, Feed End, 28 T.
- I Compound Intermediate Bevel Gear, 28 T.
- I¹ Compound Intermediate Gear, driving Bottom Feed Roll, 37 T.
- J Bottom Feed Roll, 2 in. dia.
- {42}
- J¹ Bottom Feed Roll Gear, 33 T.
- J² Cage Section Top Stripping Roll Driving Gear, 9 T.; 8 T. Gear may be used to vary speed.
- K Cage Section Top Stripping Roll Intermediate Gear, 52 T.
- L Cage Section Top Stripping Roll Gear, 14 T.
- M Cage Section Bottom Stripping Roll Gear, 14 T.
- M¹ Cage Section Bottom Cage Driving Gear, 23 T.
- N Cage Section Bottom Cage Intermediate Gear, 20 T.
- O Cage Section Bottom Cage Gear, 181 T.
- O¹ Cage Section Top Cage Gear, 181 T.
- P Front Lap Calender Roll, 9 in. dia.
- p¹ Front Lap Calender Roll Gear, 53 T.
- p² Back Lap Calender Roll Driving Gear, 24 T.
- Q Back Lap Calender Roll Intermediate Gear, 22 T.
- R Back Lap Calender Roll Gear, 24 T.
- R¹ Back Lap Calender Roll, 9 in. dia.
- S 3d Calender Roll Gear, 21 T.
- S¹ 3d Calender Roll, 5-1/2 in. dia.
- T 2d Calender Roll Gear, 22 T.
- T¹ 2d Calender Roll, 5-1/2 in. dia.
- U Top Calender Roll Gear, 23 T.
- U¹ Top Calender Roll, 5-1/2 in. dia.
- V Calender Section Top Stripping Roll Intermediate Gear, 17 T.
- V¹ Calender Section Top Stripping Roll Intermediate Gear, 17 T.
- W Calender Section Top Stripping Roll Gear, 14 T.
- X Calender Section Bottom Stripping Roll Gear, 14 T.
- X¹ Calender Section Bottom Cage Driving Gear, 23 T.
- Y Calender Section Bottom Cage Intermediate Gear, 20 T.
- Z Calender Section Bottom Cage Gear, 181 T.
- Z¹ Calender Section Top Cage Gear, 181 T.

{43}

BREAKER LAPPERS.**DRAFT CALCULATIONS.**

Rule:

$$\frac{J^1 \times I \times H \times G \times E^1 \times \text{dia. of } P}{I^1 \times H^1 \times G^1 \times E^2 \times P^1 \times \text{dia. of } J} = \text{Draft.}$$

Example:

If all standard gears,

$$\frac{33 \times 28 \times 24 \times 30 \times 12 \times 9}{37 \times 28 \times 24 \times 14 \times 53 \times 2} = 1.95 = \text{Draft.}$$

PRODUCTION CALCULATIONS

Rules:

$$\frac{\text{R. P. M. of Beater} \times \text{dia. of } B^1 \times C^1 \times D^1 \times E^1}{\text{dia. of } C \times D \times E \times P^1} = \text{R. P. M. of 9-in. Calender Roll (P).}$$

$$\frac{\text{R. P. M. of 9-in. Calender Roll (P)} \times \text{Circum. of } P \times \text{oz. per yd. of Lap} \times 600 \text{ (min. in 10 hours)}}{36 \text{ (inches in 1 yd.)} \times 16 \text{ (oz. in 1 lb.)}} = \text{Lbs. in 10 hours.}$$

Examples:

If R. P. M. of Beater = 1,450, dia. of Feed Pulley (B^1) = 5 in. Lap, 14 oz. per yd. Ten per cent. allowance for stops, etc.

$$\frac{1,450 \times 5 \times 15 \times 17 \times 12}{18 \times 35 \times 96 \times 53} = 6.921 \text{ R. P. M. of 9-in. Calender Roll (P).}$$

$$\frac{6.921 \times 28.27 \times 14 \times 600 \times .90}{36 \times 16} = 2,570 \text{ lbs. in 10 hours.}$$

Short rule for figuring production in lbs. per 10 hours when Beater makes 1,450 R. P. M. Ten per cent. allowance for stops, etc., and all gears standard.

$$36.7 \times \text{dia. of Feed Pulley} \times \text{oz. per yd. of Lap} = \text{Lbs. in 10 hours.}$$

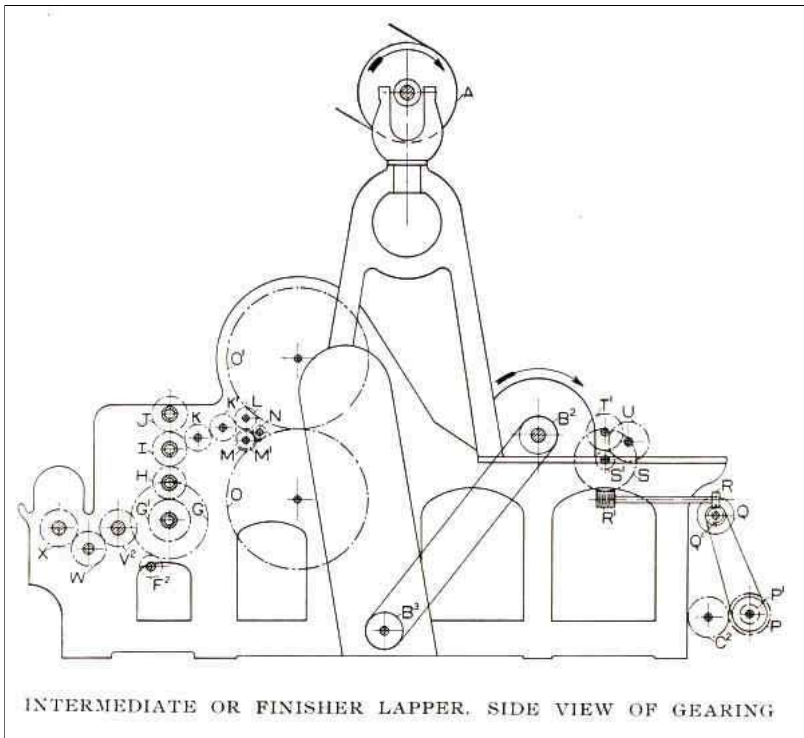

INTERMEDIATE OR FINISHER LAPPER.
SIDE VIEW OF GEARING

{45}

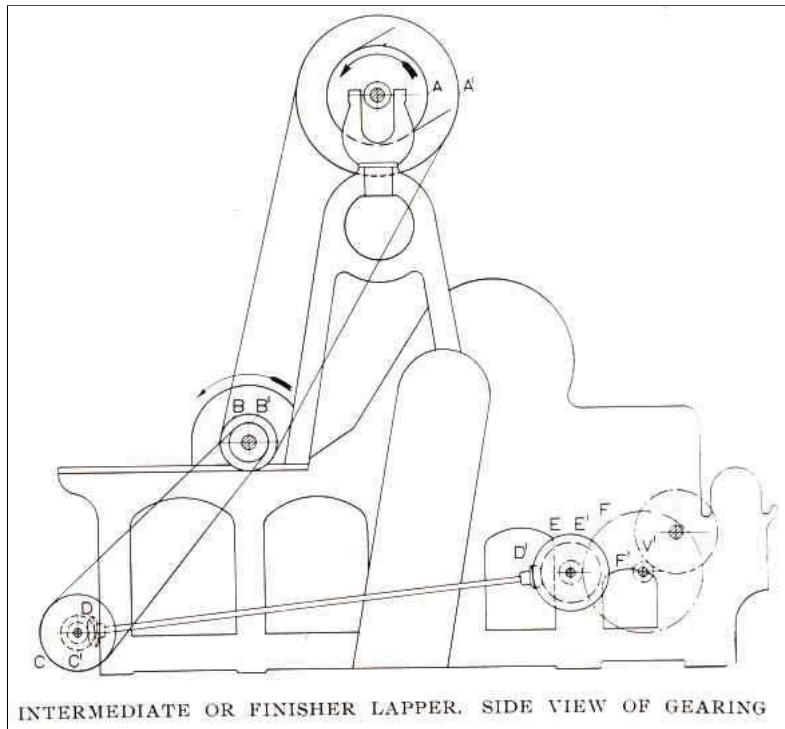

INTERMEDIATE OR FINISHER LAPPER.
SIDE VIEW OF GEARING

{46}

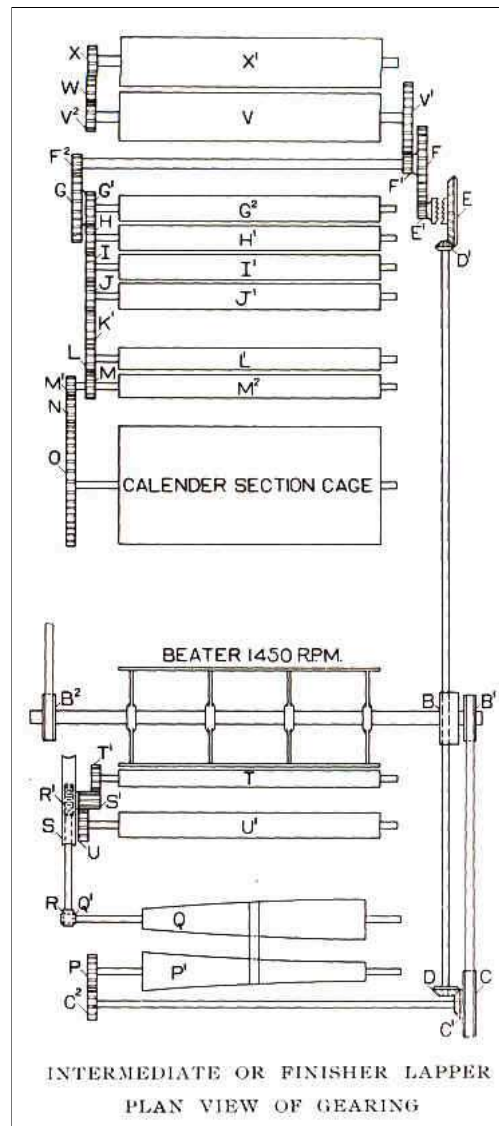

INTERMEDIATE OR FINISHER LAPPER
PLAN VIEW OF GEARING

{47}

INTERMEDIATE AND FINISHER LAPPERS.

ALPHABETICAL REFERENCES TO DRAWINGS.

- A Main Driving Pulley, 16 in. dia. x 4-1/4 in. face; 5-1/4 in. face for Two-beater Machine.
- A¹ Beater Driving Pulley, 30 in. dia. x 4-1/4 in. face. for 18-in. Rigid Beater; 22 in. dia. x 4-1/4 in. face for Carding Beater.
- B Beater Pulley, 9 in. dia. x 4-1/4 in. face (occasionally 10 in. dia.)
- B¹ Feed Pulley, 3 in. to 13 in. dia. x 2-1/4 in. face; advancing by 1/2 in. increments.
- B² Calender Section Fan Driving Pulley, 6 in. dia. x 2-1/4 in. face for 18-in. Rigid Beater, and 8 in. dia. x 2-1/4 in. face for Carding Beater.
- B³ Calender Fan Pulley. 8 in. dia. x 2-1/4 in. face.
- C Driving Pulley for Side Shaft, etc., 12 in. dia. x 2-1/4 in. face.
- C¹ Evener Cross Shaft Bevel Gear, 27 T.

- C² Evener Cross Shaft Change Gear, 55-35 T; diminishing by one tooth.
- D Side Shaft Bevel Gear, Feed End, 27 T.
- D¹ Side Shaft Bevel Gear, Calender End, 18 T.
- E Large Clutch Bevel Gear, 60 T.
- E¹ Small Clutch Gear, 17 T.
- F Calender Cross Shaft Driven Gear, 96 T.
- F¹ Front Lap Calender Roll Driving Gear, 12 T.
- F² Calender Cross Shaft Gear, driving Calender Rolls, 14 T.
- G Large Double Intermediate, driving Bottom Calender Roll, 50 T.
- G¹ Small Double Intermediate, driving Third Calender Roll 27 T.
- G² Bottom Calender Roll, 7 in. dia.
- H 3d Calender Roll Gear, 21 T.
- H¹ 3d Calendar Roll, 5-1/2 in. dia.
- I 2d Calender Roll Gear, 22 T.
- I¹ 2d Calender Roll, 5-1/2 in. dia.
- J Top Calender Roll Gear, 23 T.
- J¹ Top Calender Roll, 5-1/2 in. dia.
- K Top Stripping Roll Intermediate Gear, 17 T.
- K¹ Top Stripping Roll Intermediate Gear, 17 T.
- L Top Stripping Roll Gear, 14 T.
- {48}
- M Bottom Stripping Roll Gear, 14 T.
- M¹ Bottom Cage Driving Gear, 23 T.
- N Bottom Cage Intermediate Gear, 20 T.
- O Bottom Cage Gear, 181 T.
- O¹ Top Cage Gear, 181 T.
- P Bottom Cone Change Gear, 35-55 T; advancing by one tooth.
- p¹ Bottom Cone, driving Top Cone. Letters also represent diameters near the middle of Cones.
- Q Top Cone.
- Q¹ Worm Shaft Driving Spiral Gear, 9 T.
- R Worm Shaft Spiral Gear, 9 T.
- R¹ Worm Shaft Worm, double threaded, right hand; equivalent to Gear having two teeth.
- S Worm Gear, 78 T.
- S¹ Feed Roll and Apron Roll Driving Gear, 12 T.

- T Feed Roll, 3 in. dia.
 T¹ Feed Roll Gear, 24 T.
 U Apron Roll Gear, 29 T.
 V Front Lap Calender Roll, 9 in. dia.
 V¹ Front Lap Calendar Roll Gear, 53 T.
 V² Back Lap Calendar Roll Driving Gear, 24 T.
 W Back Lap Calender Roll Intermediate Gear, 22 T.
 X Back Lap Calender Roll Gear, 24 T.
 X¹ Back Lap Calender Roll, 9 in. dia.

{49}

INTERMEDIATE AND FINISHER LAPPERS.

DRAFT CALCULATIONS.

Rules:

$$\frac{T^1 \times S \times R \times Q \times P \times C^1 \times D^1 \times E^1 \times F^1 \times \text{dia. of } V}{S^1 \times R^1 \times Q^1 \times P^1 \times C^2 \times D \times E \times F \times V^1 \times \text{dia. of } T} = \text{Draft.}$$

The draft is variable and is figured between the Feed Roll and the Lap Calender Roll. The normal position of the Evener Cone Belt when four laps are on the apron is 5 in. from the large end of the top cone, and at this point the ratio of diameters is 1.6; that is, $\frac{Q}{P^1} = 1.6$.

The draft change gears are Bottom Cone Change Gear (P) and Evener Cross Shaft Change Gear C². Omitting these gears in the above rule,

$$\frac{T^1 \times S \times R \times Q \times C^1 \times D^1 \times E^1 \times F^1 \times \text{dia. of } V}{S^1 \times R^1 \times Q^1 \times P^1 \times D \times E \times F \times V^1 \times \text{dia. of } T} = \text{Draft Constant.}$$

$$\text{Draft Constant} \times \frac{P}{C^2} = \text{Draft.}$$

$$\frac{\text{Draft Constant}}{\text{Draft required}} = \frac{C^2}{P}$$

Examples:

If the various gears are standard and the ratio 1.6 is used for $\frac{Q}{P^1}$

$$\frac{24 \times 78 \times 9 \times 1.6 \times 27 \times 18 \times 17 \times 12 \times 9}{12 \times 2 \times 9 \times 1 \times 27 \times 60 \times 96 \times 53 \times 3} = 4.503 = \text{Draft Constant.}$$

If Bottom Cone Change Gear (P) = 40 T, Evener Cross Shaft Change Gear (C²) = 50 T. (The sum of the teeth on gears P and C² must be 90.)

$$\frac{4.503 \times 40}{50} = 3.602 = \text{Draft.}$$

If Draft required = 4.50,

$$\frac{4.503}{4.50} = 1.0 = \frac{45}{45} = \frac{C^2}{P}$$

{50}

PRODUCTION CALCULATIONS.

Rules:

$$\frac{\text{R. P. M. of Beater} \times \text{dia. of } B^1 \times C^1 \times D^1 \times E^1 \times F^1}{\text{dia. of } C \times D \times E \times F \times V^1} = \text{R. P. M. of 9-in. Calender Roll (V).}$$

$$\frac{\text{R. P. M. of 9-in. Calender Roll (V)} \times \text{Circum. of V} \times \text{oz. per yd. of Lap} \times 600 \text{ (min. in 10 hours)}}{36 \text{ (inches in 1 yd.)} \times 16 \text{ (oz. in 1 lb.)}} = \text{Lbs. in 10 hours.}$$

Examples:

If R. P. M. of Beater = 1,450, dia. of Feed Pulley (B^1) = 5 inches. Lap, 12 oz. per yd. Ten per cent. allowance for stops, etc.

$$\frac{1,450 \times 5 \times 27 \times 18 \times 17 \times 12}{12 \times 27 \times 60 \times 96 \times 58} = 7.267 \text{ R. P. M. of 9-in. Calender Roll (V).}$$

$$\frac{7.267 \times 28.27 \times 12 \times 600 \times .90}{36 \times 16} = 2,310 \text{ lbs. in 10 hours.}$$

Short rule for figuring production in lbs. per 10 hours when Beater makes 1,450 R. P. M. Ten per cent. allowance for stops, etc., and all gears standard.

$38.5 \times \text{dia. of Feed Pulley} \times \text{oz. per yd. of Lap} = \text{Lbs. in 10 hours.}$

CALCULATIONS FOR LENGTH OF LAP.**Rules:**

$$\frac{\text{Knock-off Gear} \times \text{Cir. of 7 in. Roll} \times \text{Bevel Driven Gear}}{\text{Bevel Driving Gear} \times 36 \text{ in.}} = \text{No. of Yds. in Lap.}$$

Example:

$$\frac{55 \times 21.9912 \times 31}{19 \times 36 \text{ in.}} = 54.81 \text{ Yds.}$$

NOTE—With our latest gearing arrangement, the number of teeth in Knock-off Worm Gear corresponds to the number of yards in the lap.

{51}

INTERMEDIATE AND FINISHER LAPPERS.**DRAFT TABLE.**

Bottom Cone Change Gear	Cross Shaft Change Gear	Draft	Bottom Cone Change Gear	Cross Shaft Change Gear	Draft	Bottom Cone Change Gear	Cross Shaft Change Gear	Draft
55	35	7.08	48	42	5.15	41	49	3.77
54	36	6.75	47	43	4.92	40	50	3.60
53	37	6.45	46	44	4.71	39	51	3.44
52	38	6.16	45	45	4.50	38	52	3.29
51	39	5.89	44	46	4.31	37	53	3.14
50	40	5.63	43	47	4.12	36	54	3.00
49	41	5.38	42	48	3.94	35	55	2.86

{52}

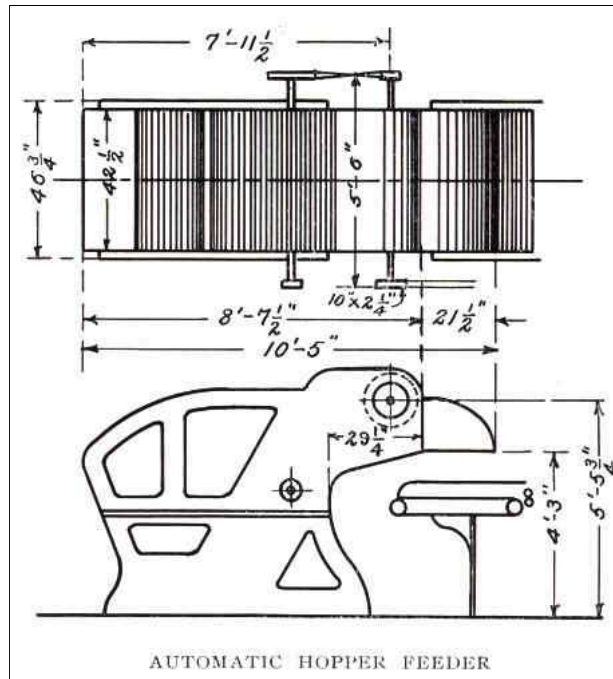

AUTOMATIC HOPPER FEEDER
AUTOMATIC HOPPER FEEDER

{53}

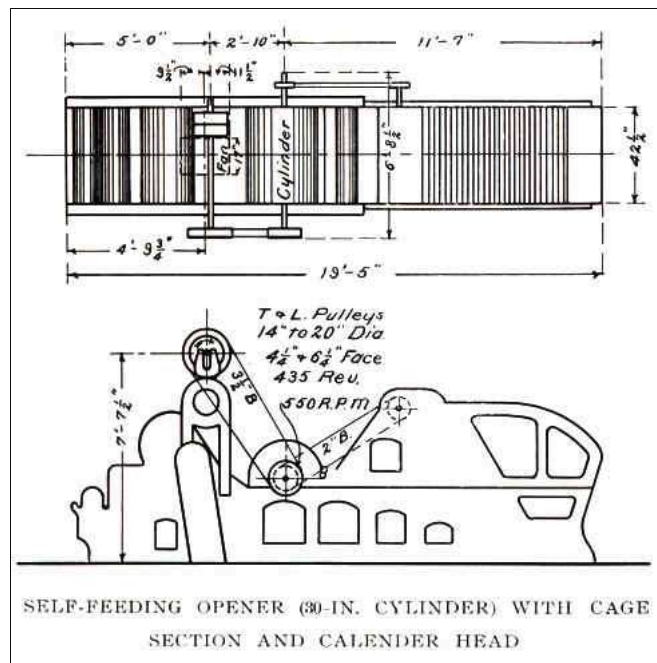

SELF-FEEDING OPENER (30-IN. CYLINDER) WITH CAGE SECTION AND CALENDER HEAD

SELF-FEEDING OPENER (30-IN. CYLINDER)
WITH CAGE SECTION AND CALENDER HEAD

{54}

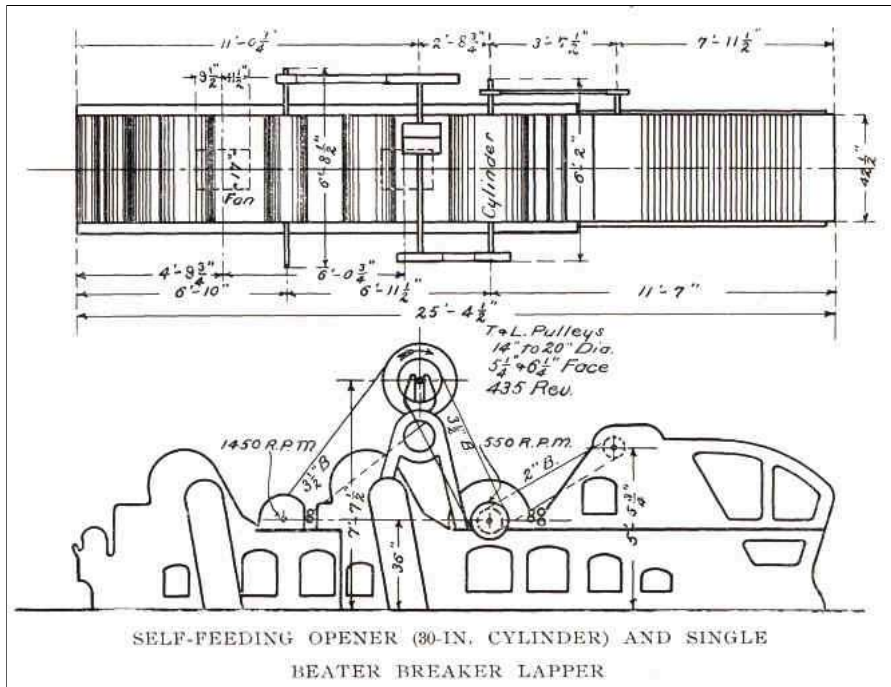

SELF-FEEDING OPENER (30-IN. CYLINDER) AND SINGLE BEATER BREAKER LAPPER

{55}

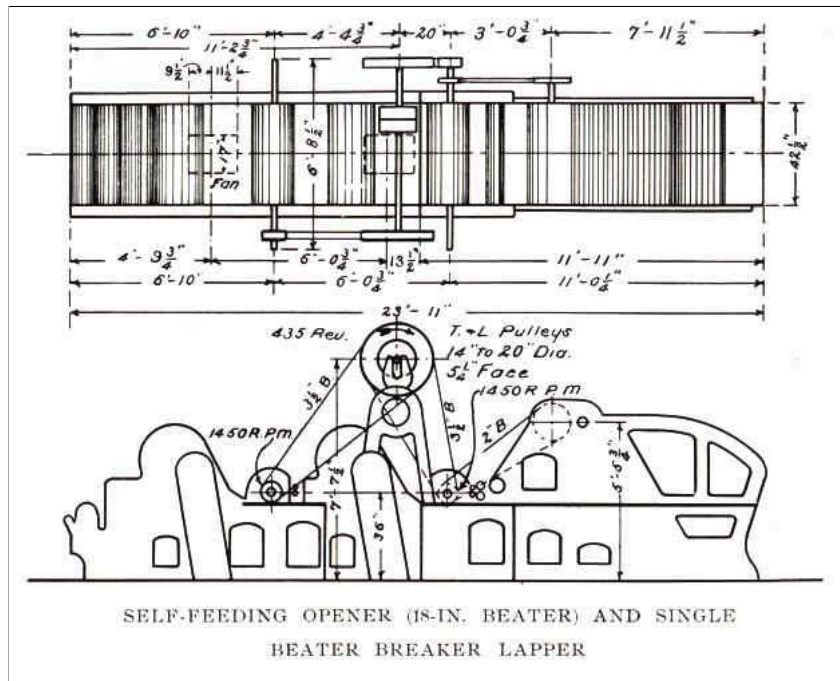

SELF-FEEDING OPENER (18-IN. BEATER) AND SINGLE BEATER BREAKER LAPPER

{56}

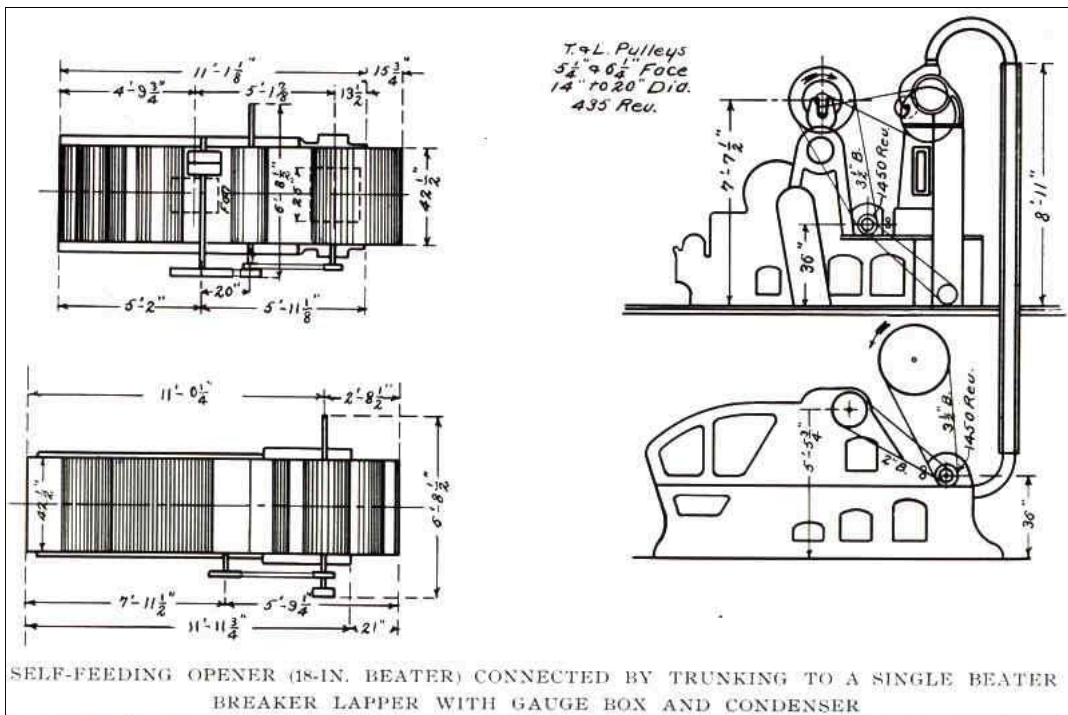

SELF-FEEDING OPENER (18-IN. BEATER) CONNECTED BY TRUNKING TO A SINGLE BEATER BREAKER LAPPER WITH GAUGE BOX AND CONDENSER

{57}

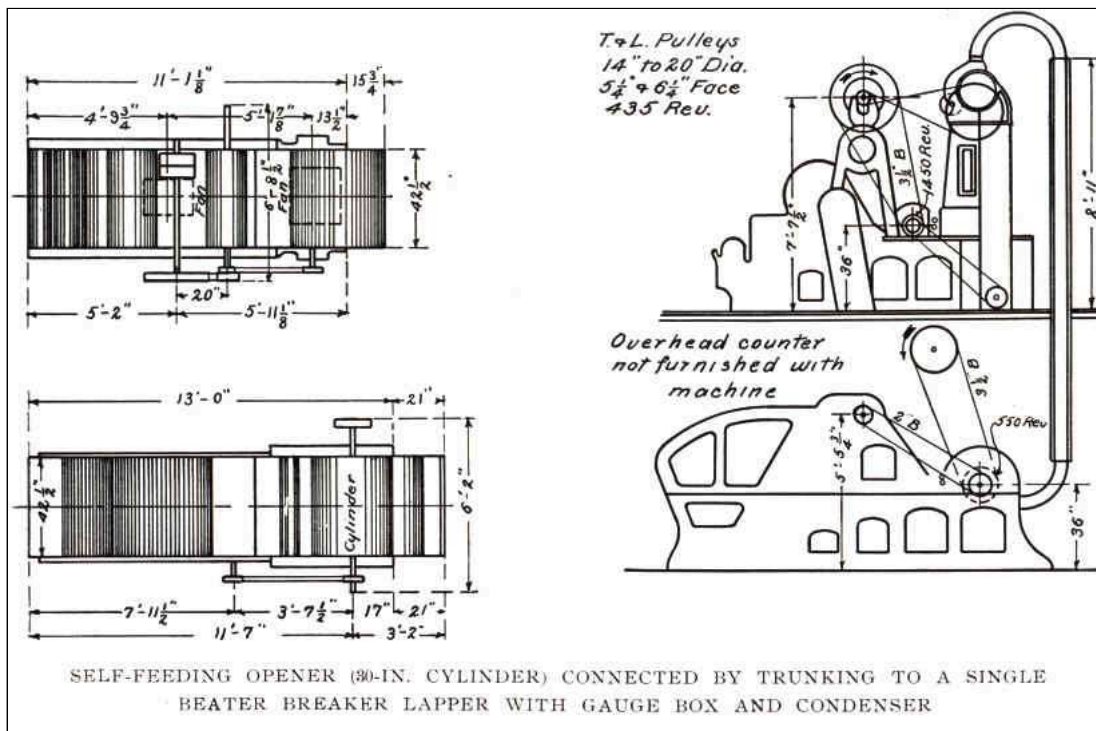

SELF-FEEDING OPENER (30-IN. CYLINDER) CONNECTED BY TRUNKING TO A SINGLE BEATER BREAKER LAPPER WITH GAUGE BOX AND CONDENSER

{58}

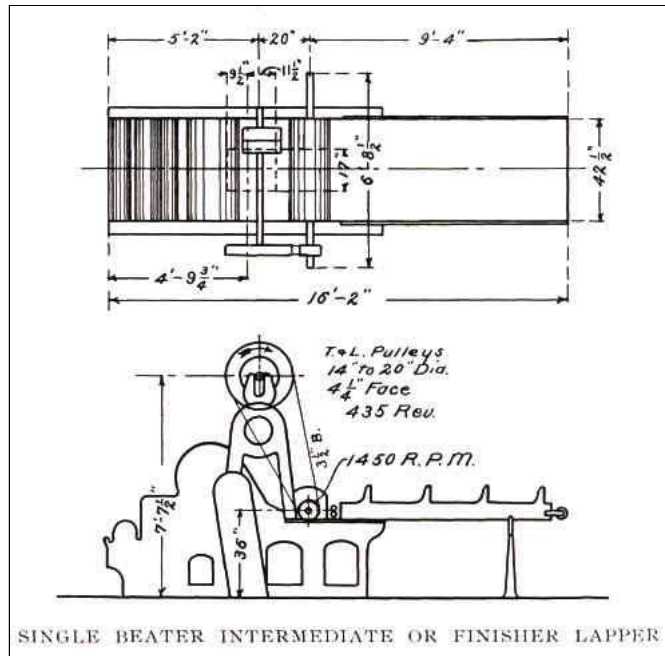

SINGLE BEATER INTERMEDIATE OR FINISHER LAPPER

{59}

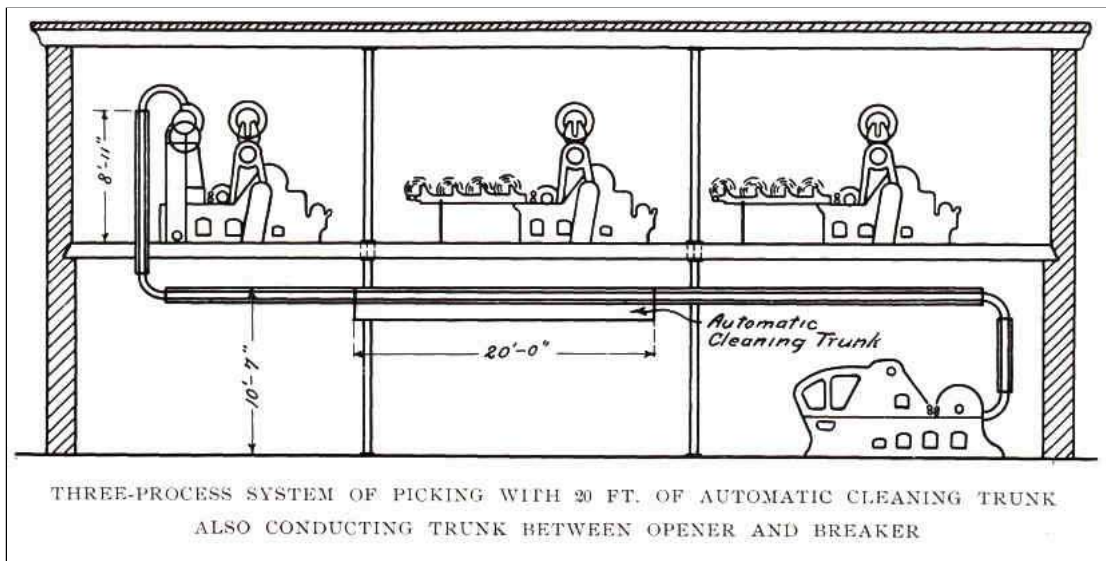

THREE-PROCESS SYSTEM OF PICKING WITH 20 FT. OF AUTOMATIC CLEANING TRUNK ALSO CONDUCTING TRUNK BETWEEN OPENER AND BREAKER

{60}

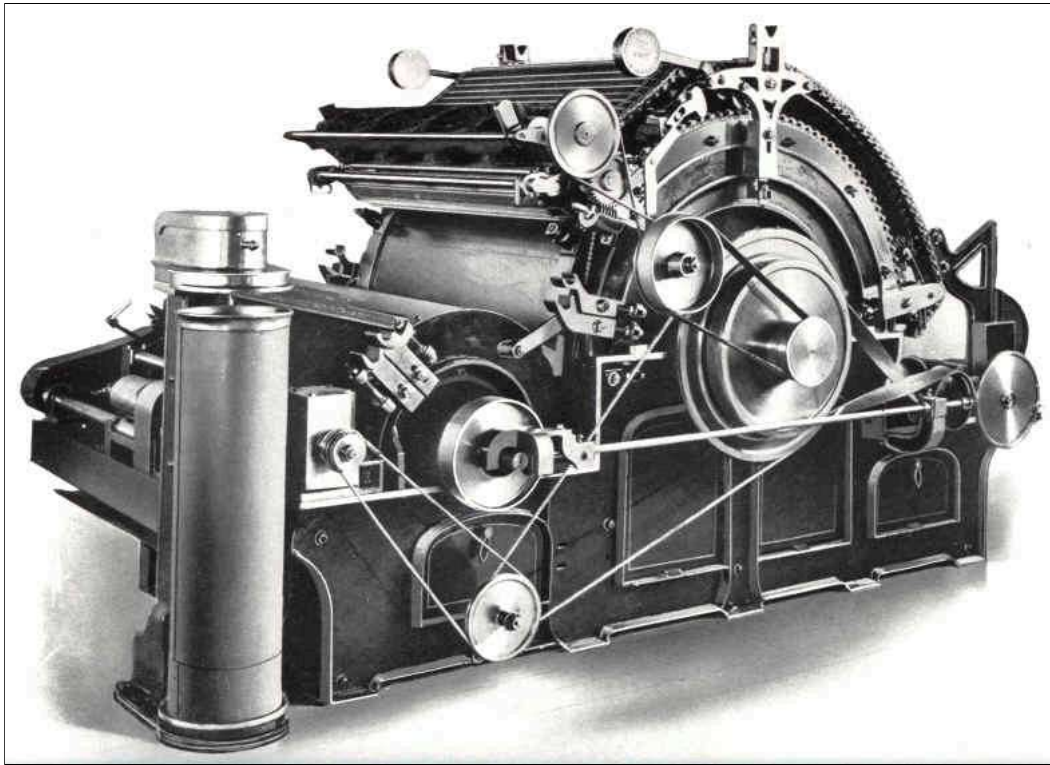

{61}

REVOLVING FLAT CARDS.

Our Cards are extensively used, and have won for themselves a high reputation for the quality and quantity of work they will do, the small percentage of waste made, and their durability and simplicity.

CHARACTERISTICS.

1. Rigid Bend, mathematically correct at all stages of wear of the wire.
2. Perfect concentricity of Flats to Cylinder. Cylinder Pedestals are adjustable.
3. Arrangements for adjusting Flats whereby accuracy to the thousandth part of an inch is obtained.
4. Better quality of yarn made from the same cotton, or equally good yarn made from cheaper cotton.
5. Card Clothing throughout is of best Hardened and Tempered Steel Wire, Plough Ground or Needle Pointed.
6. Patent Doffer Slow Motion, to facilitate piecing up of broken sliver.
7. Patent method of securing Clothing to the Flats; neatest, cleanest and most effective.
8. Patent Top Flat Grinding Arrangement for grinding from the working seating of the Flats.
9. Patent Flat Stripping Motion, which insures perfect stripping without damage to the Clothing on the Flats.
10. Back Bends or Circles for supporting Flats and preventing sagging and stretching of chains.

{62}

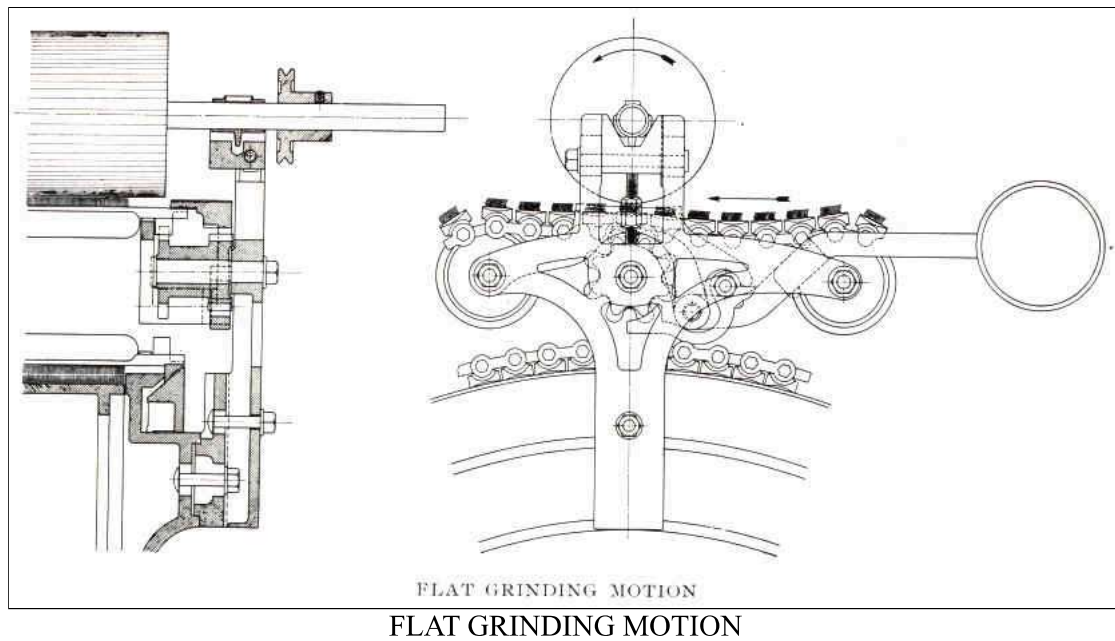

{63}

The following paragraphs briefly describe some of the points of advantage in the design and construction of our machines:

CYLINDERS AND DOFFERS are carefully balanced at a high speed and are ground after being turned, making a perfectly true surface for the Card Clothing.

GOOD SELVAGES—Both Cylinders and Doffers are clothed to the extreme edges, which prevents ragged selvages.

PROTECTION OF CLOTHING—The Doffers are provided with flanges to protect the Clothing, keep the edges firm and prevent the wire from being knocked down. Turned iron flanges on the Bends, and Segment Rings fixed to the inside of the lower part of the framing protect the edges of the Cylinders all the way round. The Doffers are made 1/8 in. wider than the Cylinders in order to keep the edges of the latter clean.

PREVENTION OF ACCUMULATION OF FLY—The Segment Rings which are fitted close to the edges of the Cylinder project in such a way as to form a circle two inches larger than the diameter of the Cylinder. The Underscreens are attached to these Segment Rings, and this arrangement makes it impossible for fly to collect inside the Screens or about the edges of the Cylinders and Doffers.

ELECTRICAL TESTS—All Bends and Flats are tested at our works by special electrical apparatus, and this method of testing gives greater accuracy than can be obtained in any other way. More accurate Bends and Flats make closer settings possible.

PERCENTAGE AND ALL CASING-OFF PLATES are made of steel, polished inside and out, and bent to conform to the surface of the cylinder. Each plate is set by gauge to the Cylinder, and the closing up of all air spaces makes the accumulation of fly and cloudy carding impossible.

ADJUSTMENTS—Convenient adjusting arrangements with setting screws and lock nuts are provided for the Knife Plates, Doffers and Licker-ins. These are all on the outside of the machine and are accessible and easily adjusted.

{64}

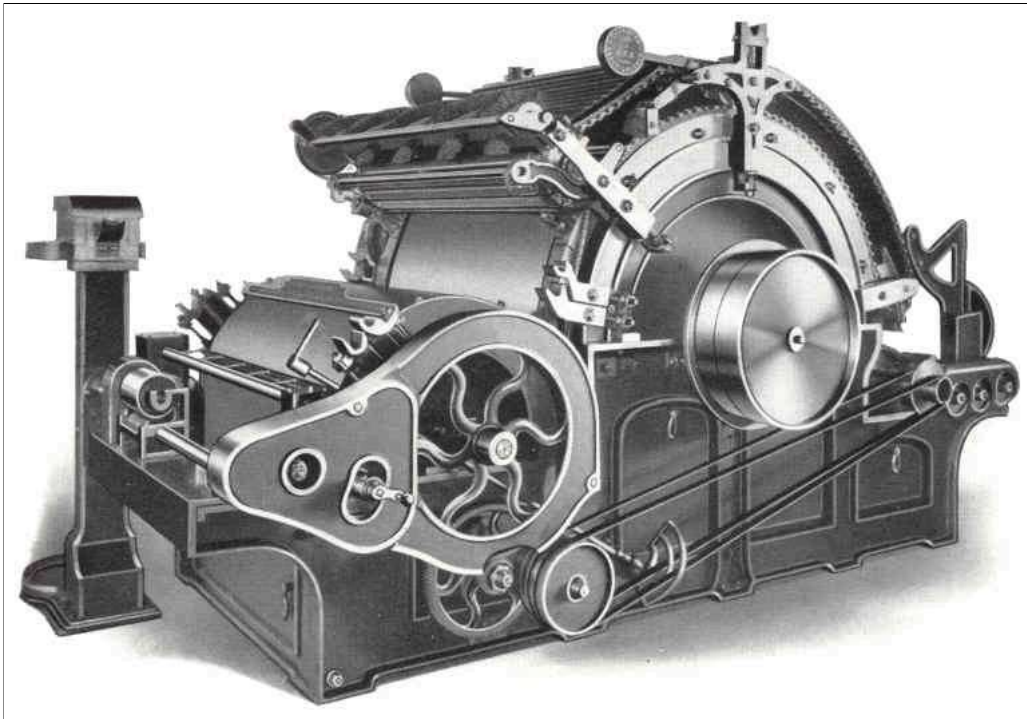

{65}

LICKER-IN SHIELDS—To prevent the accumulation of fly around the bearings and pedestals and the climbing of oil over the ends of the Licker-in onto the clothing, we supply stationary shields at each end.

UNDERSCREENS AND FEED PLATES—Our Underscreens are specially heavy and well constructed, and our Feed Plates are very carefully finished and fitted. We supply special Underscreens and Feed Plates for long staple cotton.

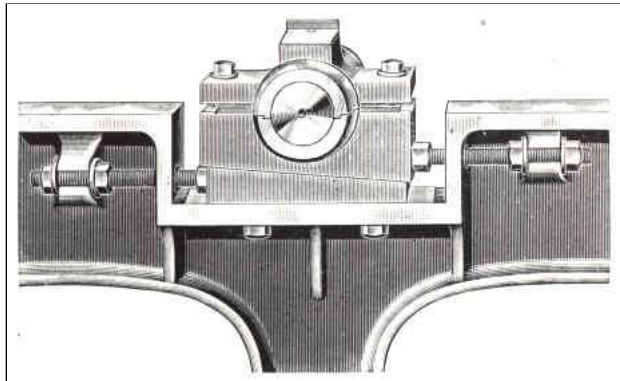

ADJUSTABLE CYLINDER PEDESTALS—The bearings for the Cylinders are made of phosphor bronze and the pedestals are adjustable either vertically or horizontally. This is a very important point, because the concentricity of the Cylinder with the Bends can be maintained as the bearings wear. The construction of our Card side is such that a very rigid support is given to the pedestals.

FLAT RELEASE—This is a very simple and convenient attachment to the Flat Driving Arrangement, which makes one of the worm gears loose on its shaft and enables the Flats to be easily turned by hand with a suitable wrench.

CONICAL BUSHINGS—The Cylinders are fastened onto the shafts by means of split conical bushings which are forced into place and prevent any possibility of the Cylinders working loose.

{66}

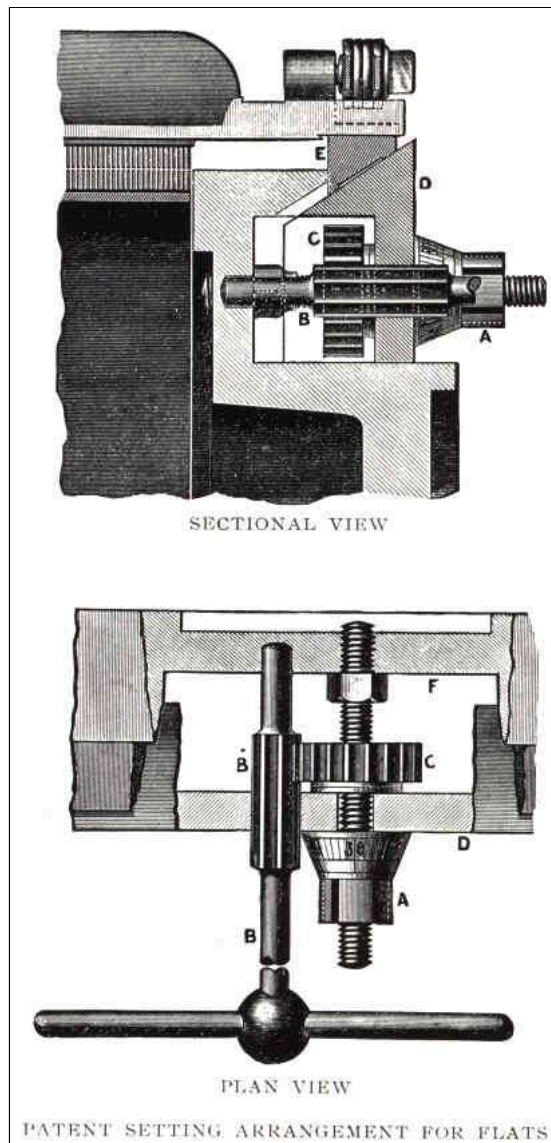

SECTIONAL VIEW

PLAN VIEW

PATENT SETTING ARRANGEMENT FOR FLATS

SECTIONAL VIEW

PLAN VIEW

PATENT SETTING ARRANGEMENT FOR FLATS

{67}

PATENT SETTING ARRANGEMENT FOR FLATS.

The cuts on [page 66](#) are sectional and plan views of this arrangement.

A—Index Nut which bears against outside of Rigid Bend D.

B—Setting Key with fluted teeth, which gear into the teeth on Nut C.

C—Toothed Steel Nut which bears against the inside of Rigid Bend D.

D—Rigid Conical Bend which is moved in or out.

E—Flexible Conical Bend which rests on D and carries the Flats.

As the Index Nuts A and the Toothed Nuts C are turned one way or the other, they move the Rigid Bend D in or out, and thus raise or lower the Flexible Bend E.

The Flats rest on the Flexible Bend E and are raised or lowered with it. Each division on the Index Nuts A represents 1/1000 part of an inch, and by turning these Nuts one division, the Flats are raised or lowered to this extent.

Our Patent Conical Concentric Bends have five setting points on each side of the machine. The Bends and Flats can be kept perfectly concentric with the Cylinder at every point until the Clothing is worn out. No other arrangement has secured such accuracy nor has any adjustment yet been invented which approaches this one for reliability and simplicity.

When the Flats are once set they remain set, and cannot be tampered with. Special wrenches are required for turning the Index Nuts A and Lock Nuts C, and if these wrenches are kept by the one who has charge of the settings, no unauthorized person can change same.

Close accurate settings enable our Card to do the finest quality of work and at the same time give the maximum production.

{68}

WILLIAMS PATENT STRIPPING MOTION.

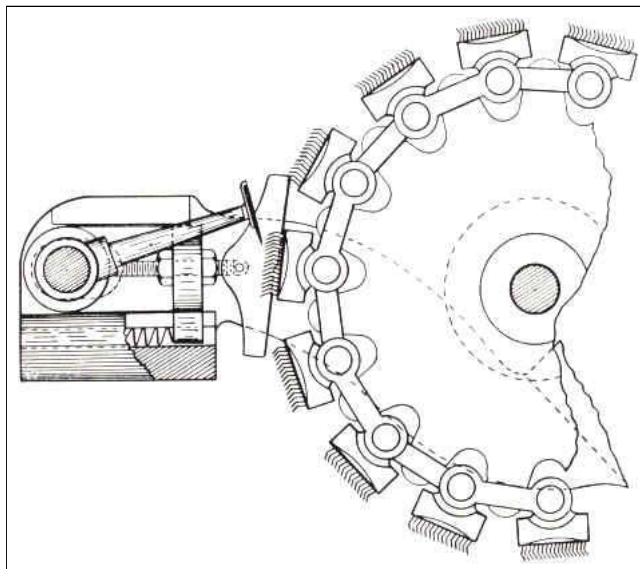

This Motion enables the Card to do better work and increases the life of the Flat clothing.

Perfect Flat Stripping can only be obtained with a Motion which keeps the Comb at an even and fixed distance from the wire clothing at all points over the entire width of the Flat. The Williams Patent Stripping Motion, for which we hold sole rights for America, meets this essential requirement and therefore does what no other Motion has succeeded in doing. In the old system, the Comb is kept at a fixed distance from the framing of the machine, which is correct as long as there is no variation in the position of the Flats as they pass under the Comb. In practice, it is impossible to {69} prevent a certain amount of tilting or raising of the Flats, due to the wearing of the chains and sprockets and also to dirt getting under the Flats. With the Williams system the stripping is perfectly done no matter what the tilting may be, and even if the Flats are forced away from their true position through any cause, the Comb follows the Flat and maintains its distance. There is no comb which will not catch and damage the wire if the setting becomes too close on account of the clearance not being kept uniform.

In the Williams Stripping Motion the Comb stock is mounted at each end in bearings which slide in guides away from or toward the Flats. The accurate setting of the Comb is maintained by means of shoes which press against the working seatings of the Flats and govern the position of the sliding Comb stock bearings. The shoes have adjusting screws to regulate the setting of the Comb, and the shape of the shoes is such as to allow for the heel of the flat. The sliding bearings of the Comb stock are pressed inward by springs which keep the shoes against the working seatings of the Flat. The Comb blade is given a receding motion which effectually strips all impurities from the wire. This action, together with the fact that it is impossible for the wire on the Flats to be forced into the Comb through the accumulation of dirt or fly on the blocks or Flat seatings, makes this Stripping Motion the most perfect on the market.

{70}

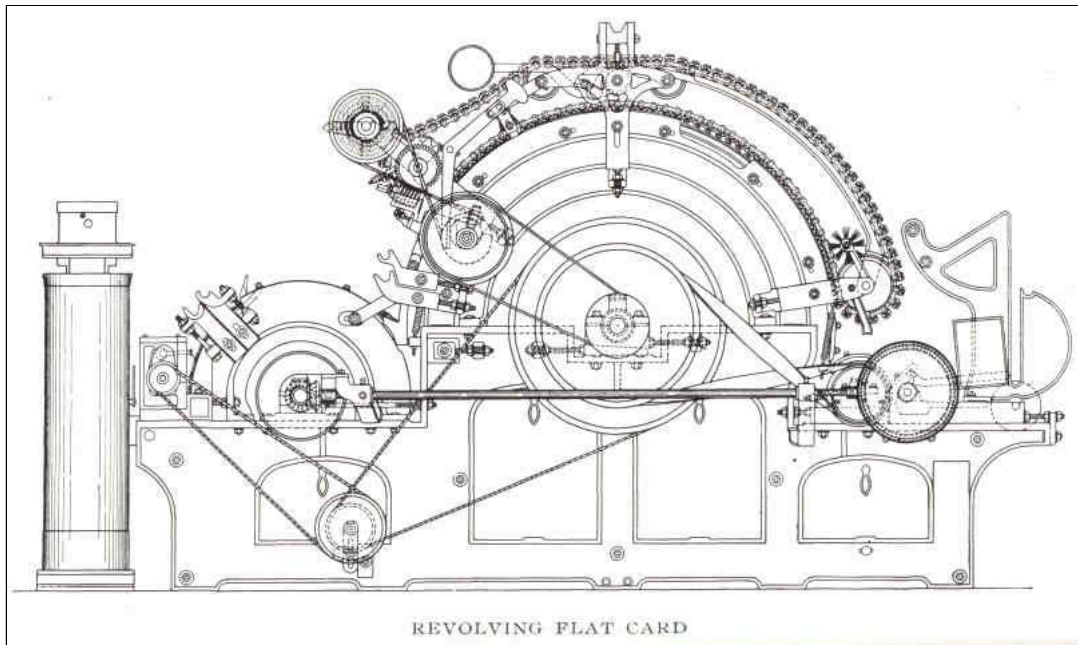

REVOLVING FLAT CARD
REVOLVING FLAT CARD

{71}

STANDARD DIMENSIONS.

Cylinder, 50 in. dia. on iron.

Doffer, 26 in. dia. on iron.

Licker-in, 9 in. dia., clothed with inserted metallic Saw Teeth.

110 Flats, 43 of which are working on the Cylinder at the same time.

HAND OF MACHINE—Cards are usually built Right Hand, i. e., with driving pulleys on right hand side when facing feed or lap. Left hand machines are built when specified.

DRIVING PULLEYS—20 in. dia., 3-1/8 in. face, T. & L. **SPEED**—Cylinder, 160 to 170 r. p. m., usually 165 r. p. m.

PRODUCTION—This is determined by the quality of carding required and the kind and grade of cotton used, and varies largely.

American	600 to 1,200 lbs.	in 60 hours.
Egyptian	400 to 650 lbs.	in 60 hours.
Sea Island	200 to 400 lbs.	in 60 hours.
Peeler	300 to 600 lbs.	in 60 hours.

FLOOR SPACE.

Length of Card over all (10-in. coiler) 10 ft. 4 in.

Length of Card over all (12-in. coiler) 10 ft. 5 in.

Width of Card, 40 in. wide on wire (40 in. to 41 in. lap) 5 ft. 6 in.

Width of Card, 45 in. wide on wire (45 in. to 46 in. lap) 5 ft. 11 in.

See [page 72](#) for floor plan.

{72}

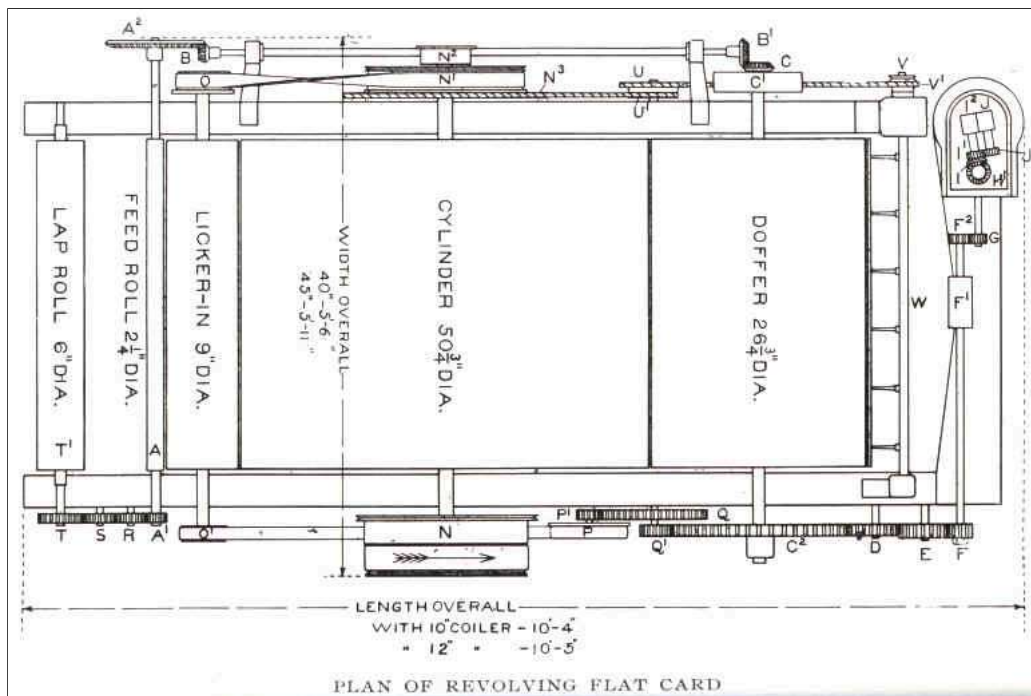

PLAN OF REVOLVING FLAT CARD

{73}

REVOLVING FLAT CARD.

ALPHABETICAL REFERENCES TO DRAWING.

- A Feed Roll, 2-1/4 in. dia.
- A¹ Feed Roll Spur Gear, 17 Teeth.
- A² Large Plate Bevel Gear, usually 120 Teeth.
- B Draft Change Gear, 10 to 30 Teeth
- B¹ Side Shaft Bevel Gear, 22 Teeth (or 34).
- C Doffer Bevel Gear 22 Teeth (or 24).
- C¹ Grinding Pulley, 11 in. dia., 2-1/4 in. face.
- C² Doffer Gear, 180 Teeth.
- D Disengaging Intermediate Gear, 51 Teeth.
- E Calender Intermediate Gear, 51 Teeth.
- F Calender Change Gear, 18 or 19 Teeth.
- F¹ Bottom Calender, 2-7/8 in. dia.
- F² Coiler Driving Gear, 24 or 25 Teeth.
- G Coiler Change Gear, 16 Teeth.
- G¹ Coiler Driving Bevel Gear, 20 Teeth.
- H¹ Coiler Top Upright Bevel Gear, 20 Teeth.
- I Coiler Calender Bevel Gear, 20 Teeth.
- I¹ 1st Coiler Calender Spur Gear, 20 Teeth.
- I² 1st Coiler Calender, 2 in. dia.

- J 2nd Coiler Calender, 2 in. dia.
- J¹ 2nd Coiler Calender Spur Gear, 20 Teeth.
- N Driving Pulley, 20 in. dia., 3-1/8 in. face; Band Pulley, 21-3/4 in. dia.
- N¹ Licker-in Driving Pulley, 19 in. dia., 2-1/4 in. face.
- N² Flat Driving Pulley, 6-1/2 in. dia., 3-1/4 in. face.
- N³ Comb Driving Band Pulley, 22 in. dia. for 5/16 in. dia. band.
- O Licker-in Driven Pulley, 7 in. dia., 2-1/4 in. face.
- O¹ Barrow Gear Driving Pulley, 6 in. dia., 2-1/8 in. face.
- P Barrow Gear Driven Pulley, 9 in. dia., 1-1/2 in. face.
- P¹ Barrow Spur Gear, usually 26 Teeth, also 24 and 28 Teeth.
- Q Doffer Lever Intermediate Gear, 104 Teeth.
- Q¹ Doffer Change Gear, 17 to 40 Teeth.
- R 1st Lap Roll Intermediate Gear, 40 Teeth.
- S 2nd Lap Roll Intermediate Gear, 40 Teeth.
- T Lap Roll Gear, 48 Teeth.
- T¹ Lap Roll, 6 in. dia.
- U Double Band Intermediate Pulley for Comb 9-3/8 in. dia.
- U¹ Double Band Intermediate Pulley for Comb 6 in. dia.
- V Comb Box Pulley 3-3/8 in. dia.
- V¹ Comb Box Pulley 4-1/8 in. dia.
- W Doffer Comb.

{74}

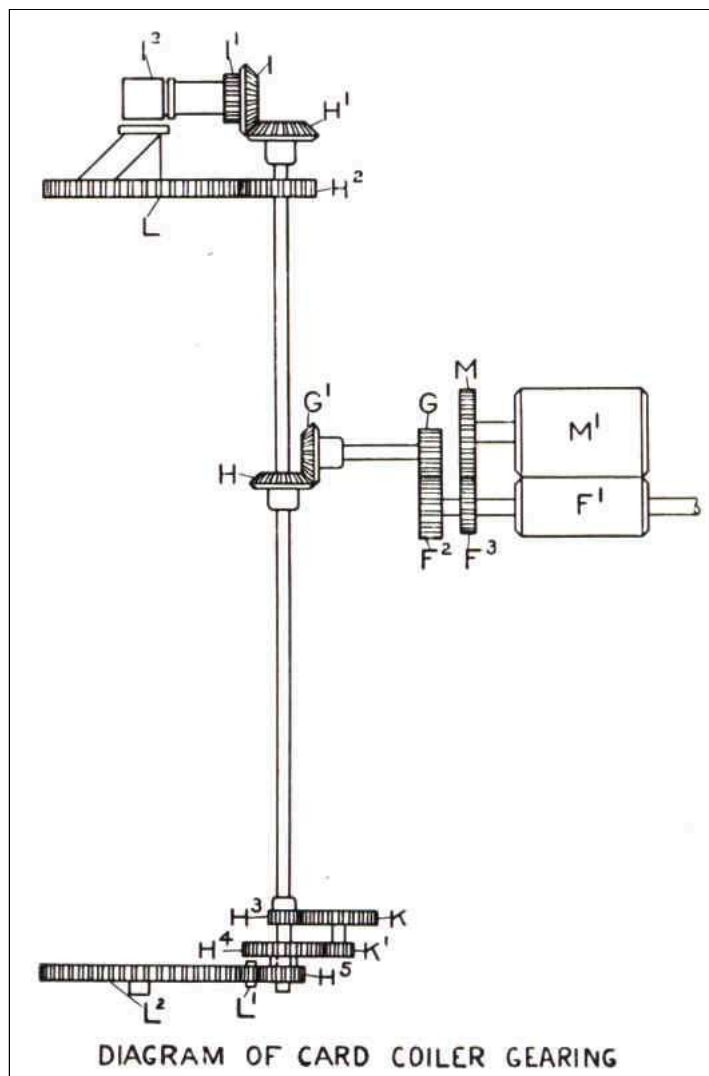

DIAGRAM OF CARD COILER GEARING

- F² Coil Driving Gear; 24 Teeth for 10-in. Coiler, 25 Teeth for 12-in. Coiler.
- F³ Top Calender Driving Gear, 23 Teeth.
- G Coiler Change Gear, 16 Teeth.
- G¹ Coiler Driving Bevel Gear, 20 Teeth.
- H Coiler Middle Upright Bevel Gear, 20 Teeth.
- H¹ Coiler Top Upright Bevel Gear, 20 Teeth.
- H² Tube Gear Driving Gear, 25 Teeth.
- H³ Upright Shaft Can Bottom Driving Gear. 15 Teeth.
- H⁴ Coiler Double Intermediate Gears, 44 Teeth.
- H⁵ Coiler Double Intermediate Gears, 15 Teeth.
- I Coiler Calender Bevel Gear, 20 Teeth.
- I¹ 1st Coiler Calender Spur Gear, 20 Teeth.
- I² 1st Coiler Calender, 2 in. dia.
- K Coiler Double Intermediate Gears, 44 Teeth.

- K¹ Coiler Double Intermediate Gears, 15 Teeth.
 L Tube Gear, 75 Teeth for 10-in. Coiler, 98 Teeth for 12-in. Coiler.
 L¹ Can Bottom Intermediate Gear; 17 Teeth for 10-in. Coiler; 22 Teeth for 12-in. Coiler.
 L² Can Bottom Gear, 84 Teeth.
 M Top Calender Gear, 34 Teeth.
 M¹ Top Calender, 4-1/4 in. dia.

{75}

REVOLVING FLAT CARDS.

DRAFT CALCULATIONS.

Rules:

$$\frac{T \times A^2 \times B^1 \times C^2 \times F^2 \times \text{dia. of } I^2}{A^1 \times C \times F \times G \times \text{dia. of } T^1} = \text{Draft Constant.}$$

$$\frac{\text{Draft Constant}}{\text{Draft Change Gear (B)}} = \text{Draft.}$$

$$\frac{\text{Draft Constant}}{\text{Draft required}} = \text{Draft Change Gear (B).}$$

Examples:

If Plate Bevel Gear (A²) = 120 T, Side Shaft Bevel Gear (B¹) = 22 T, Doffer Bevel Gear (C) = 22 T. All other gears standard.

$$\frac{48 \times 120 \times 22 \times 180 \times 24 \times 2}{17 \times 22 \times 19 \times 16 \times 6} = 1604.95 = \text{Draft Constant.}$$

If Draft Change Gear (B) = 18 T,

$$\frac{1604.95}{18} = 89.2 = \text{Draft.}$$

If Draft required = 100,

$$\frac{1604.95}{100} = 16 \text{ T} = \text{Draft Change Gear (B).}$$

PRODUCTION CALCULATIONS.

Rule:

$$\frac{\text{R. P. M. of Cylinder} \times \text{dia. of } N^1 \times \text{dia. of } O^1 \times P^1 \times Q^1}{\text{dia. of } O \times \text{dia. of } P \times Q \times C^2} = \text{R. P. M. of Doffer.}$$

Example:

If R. P. M. of Cylinder = 165, Barrow Spur Gear (P¹) = 26 T, Doffer Change Gear (Q¹) = 29 T. All other gears standard.

$$\frac{165 \times 19 \times 6 \times 26 \times 29}{7 \times 9 \times 104 \times 180} = 12.03 \text{ R. P. M. of Doffer.}$$

{76}

76

Rule:

$$\frac{\text{R. P. M. of Doffer} \times C^2 \times F^2 \times \text{Circum. of } I^2 \times \text{Wt. of Sliver in grains} \times 600 \text{ (min. in 10 hours)}}{F \times G \times 7,000 \text{ (grains in 1 lb.)} \times 36 \text{ (inches in 1 yd.)}} = \text{Lbs. in 10 hours.}$$

Example:

If R. P. M. of Doffer = 12. Sliver 60 grains per yd.
Five per cent. allowance for cleaning, stripping, etc.
All gears standard.

$$\frac{12 \times 180 \times 24 \times 6.283 \times 60 \times 600 \times .95}{19 \times 16 \times 7,000 \times 36} = 145 \text{ lbs. in 10 hours.}$$

Short rule for production in lbs. per 10 hours with standard gears and 5 per cent. allowance for cleaning, stripping, etc.

.202 x R. P. M. of Doffer x grains per yd. of Sliver = Lbs. in 10 hours.

To find the proper Doffer Change Gear for any required production, determine the proper R. P. M. of Doffer for the weight of Sliver in use from table on page 78, and then select the corresponding Doffer Change Gear by referring to table on page 77.

{77}

REVOLVING FLAT CARD.

DOFFER CHANGE GEAR TABLE.

Doffer Change Gear	Rev. per Min. of 26-in. Doffer based on 165 Rev. per Min. of Cylinder		
	Barrow Spur Gear		
	24 Teeth	26 Teeth	28 Teeth
17	6.51	7.05	7.59
18	6.89	7.46	8.04
19	7.27	7.88	8.49
20	7.66	8.29	8.93
21	8.04	8.71	9.38
22	8.42	9.12	9.83
23	8.80	9.54	10.27
24	9.19	9.95	10.72
25	9.57	10.37	11.17
26	9.95	10.78	11.61
27	10.34	11.20	12.06
28	10.72	11.61	12.50
29	11.10	12.03	12.95
30	11.48	12.44	13.40
31	11.87	12.86	13.84
32	12.25	13.27	14.29
33	12.63	13.68	14.74
34	13.02	14.10	15.18
35	13.40	14.51	15.63
36	13.78	14.93	16.08
37	14.16	15.34	16.52
38	14.55	15.76	16.97
39	14.93	16.17	17.42
40	15.31	16.59	17.86

NOTE

Licker-in Driving Pulley, 19 in. dia.

Licker-in Driven Pulley, 7 in. dia.

Barrow Gear Driving Pulley, 6 in. dia.

Barrow Gear Driven Pulley, 9 in. dia.

Doffer Lever Intermediate Gear, 104 Teeth.

Doffer Gear, 180 Teeth.

{78}

REVOLVING FLAT CARD.

PRODUCTION PER DAY OF TEN HOURS.

Doffer 26" Dia.	Weight in grains of one yard of Sliver												
	30	35	40	45	50	55	60	65	70	75	80	85	90
R. P. M.	Lbs.	Lbs.	Lbs.	Lbs.	Lbs.	Lbs.	Lbs.	Lbs.	Lbs.	Lbs.	Lbs.	Lbs.	Lbs.
6	36	42	48	55	61	67	73	79	85	91	97	103	109
6½	39	46	53	59	66	72	79	85	92	98	105	112	118
7	42	49	57	64	71	78	85	92	99	106	113	120	127
7½	45	53	61	68	76	83	91	98	106	114	121	129	136
8	48	57	65	73	81	89	97	105	113	121	129	137	145
8½	51	60	69	77	86	94	103	112	120	129	137	146	154
9	55	64	73	82	91	100	109	118	127	136	145	154	164
9½	58	67	77	86	96	106	115	125	134	144	153	163	173
10	61	71	81	91	101	111	121	131	141	151	162	172	182
10½	64	74	85	95	106	117	127	138	148	159	170	180	191
11	67	78	89	100	111	122	133	144	155	167	178	189	200
11½	70	81	93	105	116	128	139	151	163	174	186	197	209
12	73	85	97	109	121	133	145	157	170	182	194	206	218
12½	76	88	101	114	126	139	151	164	177	189	202	215	227
13	79	92	105	118	131	144	158	171	184	197	210	223	236
13½	82	95	109	123	136	150	164	177	191	204	218	232	245
14	85	99	113	127	141	156	170	184	198	212	226	240	254
14½	88	102	117	132	146	161	176	190	205	220	234	249	264
15	91	106	121	136	151	167	182	197	212	227	242	257	273
15½	94	110	125	141	157	172	188	203	219	235	250	266	282
16	97	113	129	145	162	178	194	210	226	242	258	275	291
16½	100	117	133	150	167	183	200	217	233	250	267	283	300
17	103	120	137	154	172	189	206	223	240	257	275	292	309
17½	106	124	141	159	177	194	212	230	247	265	283	300	318
18	109	127	145	164	182	200	218	236	254	273	291	309	327

NOTE—5 per cent. has been deducted in the above table for cleaning, stripping, etc.

{79}

REVOLVING FLAT CARD.

DRAFT TABLE.

Draft Change Gear	Plate Bevel Gear, 120 T. Side Shaft Bevel, 22 T. Doffer Bevel Gear, 22 T. Draft Constant, 1604.95	Plate Bevel Gear, 120 T. Side Shaft Bevel, 34 T. Doffer Bevel Gear, 24 T. Draft Constant, 2273.68	Plate Bevel Gear, 170 T. Side Shaft Bevel, 34 T. Doffer Bevel Gear, 24 T. Draft Constant, 3221.05
10	160.5		
11	145.9		
12	133.7	189.5	
13	123.5	174.9	
14	114.6	162.4	230.0
15	107.0	151.6	214.7
16	100.3	142.1	201.3
17	94.4	133.7	189.5
18	89.2	126.3	179.0
19	84.5	119.7	169.5
20	80.2	113.7	161.0
21	76.4	108.3	153.4
22	73.0	103.3	146.4
23	69.8	98.9	140.0
24	66.9	94.7	134.2
25	64.2	90.9	128.8
26	61.7	87.4	124.0
27	59.4	84.2	119.3
28	57.3	81.2	115.0
29	55.3	78.4	111.1
30	53.5	75.8	107.4

NOTE—The draft is figured between the 6 in. dia. Lap Roll and 2 in. dia. Coiler Calender Rolls.

DECIMAL EQUIVALENTS.

1 ounce = 437.5 grains	11 ounces = 4812.5 grains
2 ounces = 875 grains	11½ ounces = 5031.25 grains
3 ounces = 1312.5 grains	12 ounces = 5250 grains
4 ounces = 1750 grains	12½ ounces = 5468.75 grains
5 ounces = 2187.5 grains	13 ounces = 5687.5 grains
6 ounces = 2625 grains	13½ ounces = 5906.25 grains
7 ounces = 3062.5 grains	14 ounces = 6125 grains
8 ounces = 3500 grains	14½ ounces = 6343.75 grains
9 ounces = 3937.5 grains	15 ounces = 6562.5 grains
10 ounces = 4375 grains	15½ ounces = 6781.25 grains
10½ ounces = 4593.75 grains	16 ounces = 7000 grains

{80}

CARD CLOTHING.

The English system of numbering Card Clothing is now generally used by Cotton Mills. We give below the numbers and points per square foot:

Numbers	Pts. per Square Foot
80s	57,600
90s	64,800
100s	72,000
110s	79,200
120s	86,400
130s	93,600

The following numbers are generally used for Cylinders: Coarse, heavy work, 80s and 90s; medium to fine work, 100s and 110s; fine work, 120s and 130s.

Doffers are usually 10 numbers higher or finer than Cylinders.

There is considerable variation in the Clothing used for Tops. Some prefer thinner set than the Cylinders, others about the same as the Cylinders, and a few the same numbers as the Doffers.

{81}

{82}

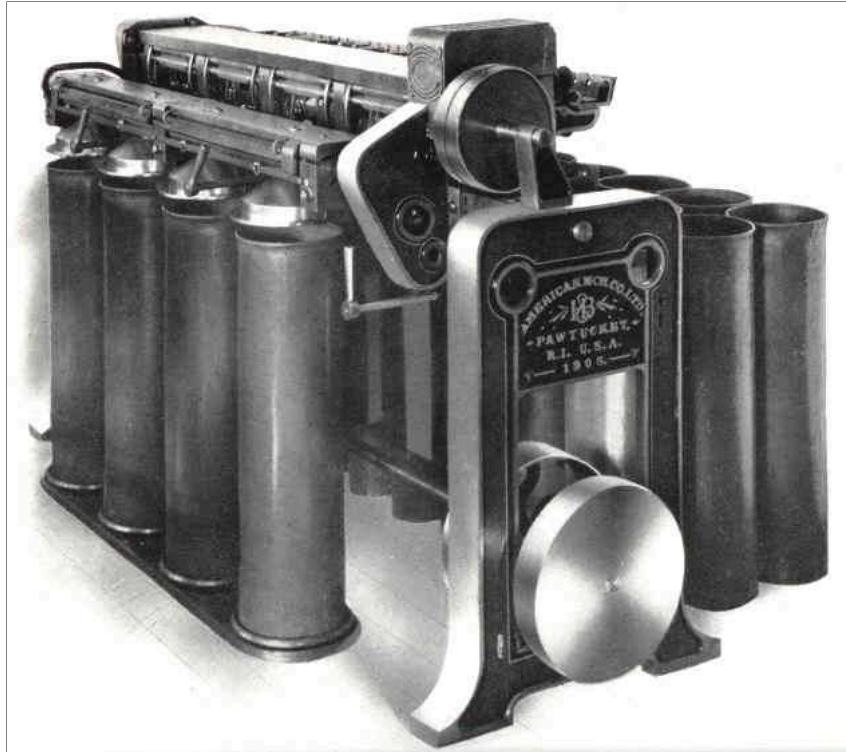

{83}

DRAWING FRAMES.

The Howard & Bullough Patent Electric Stop Motion Drawing Frame has proved one of the most successful machines ever invented, and there are large numbers of deliveries at work in every Cotton Spinning country.

We build both Electric and Mechanical Stop Motion Frames, but the great majority of our orders are for machines with Electric Stop Motions.

The quality of sliver produced by these machines cannot be surpassed; a great saving in waste "single" and roller laps is effected, and production is increased.

Machines stop:

- 1st—When sliver breaks at back or a can runs out.
- 2d—When top or bottom front roll laps up.
- 3d—When sliver breaks in front.
- 4th—When cans are full.
- 5th—When back electric roll or clearer laps up.

On account of the positive and quick action of the Electric Stop Motions, machines can be run at a much higher speed, in case of necessity, than Mechanical Stop Motion Frames.

The tops of Electric Stop Motion Frames, being free from the many small parts and projections which are a necessity on Mechanical Stop Motion Frames, are much more easily kept clean, and "fly" is not carried into the sliver, besides which a great many delicate and troublesome Mechanical Stop Motion parts are done away with.

{84}



{85}

FRAMING AND CONSTRUCTION—The machines are built with low, rigid framing. Can tables set into or on top of the floor.

BOTTOM FLUTED ROLLS are made in one length and are irregularly fluted so as to prevent cutting of top rolls. The usual diameters are 1-3/8 in. front, 1-1/8 in. second, third and fourth lines.

TOP ROLLS are usually 1 in. dia. on iron. The front line can have Loose Boss or Loose Ends; the latter are now in extensive use and are generally preferred.

ROLLER STANDS are made with separate adjustable slides or bearings, so arranged that the top and bottom rolls move together when setting for different lengths of staple. The Roller Stands and Slides have brasses cast in them for roller bearings.

CALENDER ROLLS are made of steel, turned, ground and polished.

DRAFT GEARING—All Draft and Roller Gears are cut. Changes of Draft are very easily made, and the gearing is well protected with polished covers.

COILERS are made for cans 36 ins. long, 9, 10, 11 or 12 ins. dia. as required.

TENSION—Our fine pitch gearing for the take-up of the sliver between the fluted rolls and the Calender rolls enables a nice adjustment to be made for either ordinary or metallic rolls, and reduces the stretching, sagging and breakage of the sliver, preventing stoppage and waste.

TRUMPETS—These are made separate from the calender plates and can easily be taken out. This method is an advantage over the old style, as trumpets wear in time and when worn do not sufficiently condense the sliver. With this system they can easily be replaced.

BACK GUIDES for both Electric and Mechanical Stop Motion Frames are designed so as to separate the slivers and keep kinks from going into the rolls, thus preventing lumpy and uneven work.

{86}

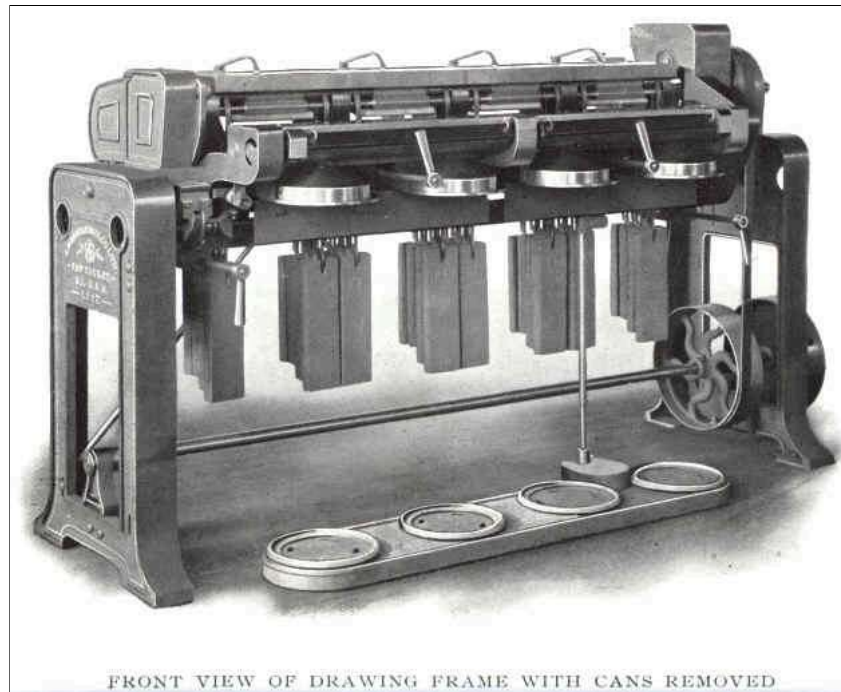

FRONT VIEW OF DRAWING FRAME WITH CANS REMOVED

{87}

CLEARERS—Both top and bottom rolls have Clearers. We apply a patented and very successful Clearer to the Calender rolls which prevents fly from sticking to them and being carried in to the sliver.

WEIGHT RELIEVING MOTION—This is applied to all frames for taking the pressure off the rolls when the frames are stopped.

All rolls are weighted separately. Usual weights are 20 lbs. front line; 18 lbs. second line; 16 lbs. third line; 14 lbs. fourth line.

TRAVERSE MOTION is applied to all frames with leather covered top rolls.

METALLIC TOP AND BOTTOM ROLLS—The front bottom roll is usually 1-3/8 in. dia., and the other three lines of bottom rolls as well as the top rolls, all 1-1/8 in. dia.

Front and second lines are usually 32 pitch; third line 24 pitch and back line 16 pitch. The top rolls have Loose Ends. Weights usually 14 lbs. on all lines.

ERMEN TOP CLEARERS—The cloth of these Clearers revolves over 2 rolls (one of which is positively driven) and comes in contact with all the top rolls. This revolving clearer is placed inside of our top clearer cover, and is stripped by a Comb through an opening in the top of the cover. This clearer meets with great favor in fine mills, where combed long staple cotton is worked.

DRIVING PULLEY AND SPEED—The Driving Pulley on the Bottom Shaft is usually 16 in. dia., 3 in. or 4 in. face and can be placed at either end of the frame. The usual speed of this shaft is 250 r. p. m., which gives a calculated speed of 363 r. p. m. of Front Roll. One rev. of shaft equals 1-5/11 of Front Roll.

{88}

FLOOR PLANS OF DRAWING FRAMES.

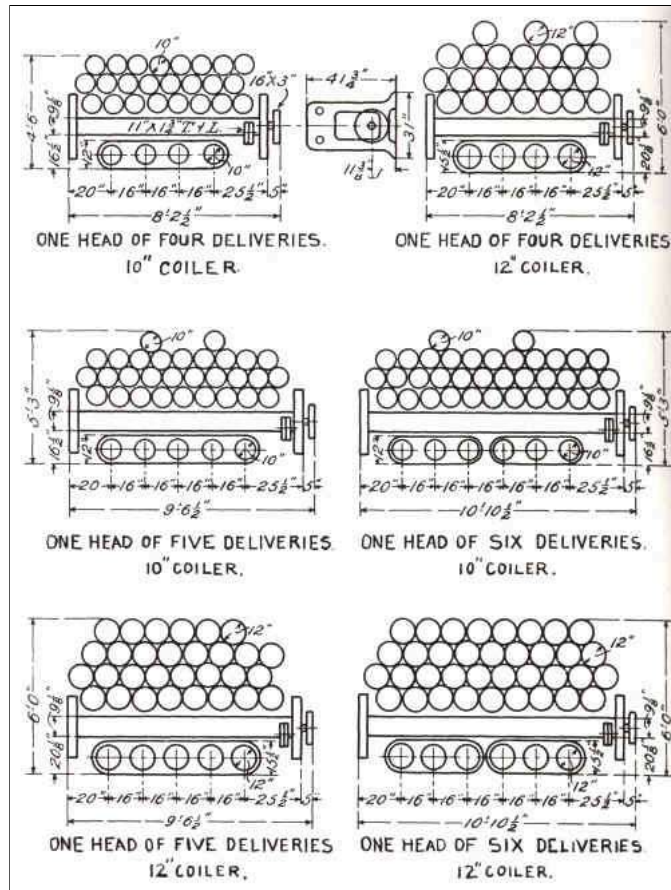

{89}

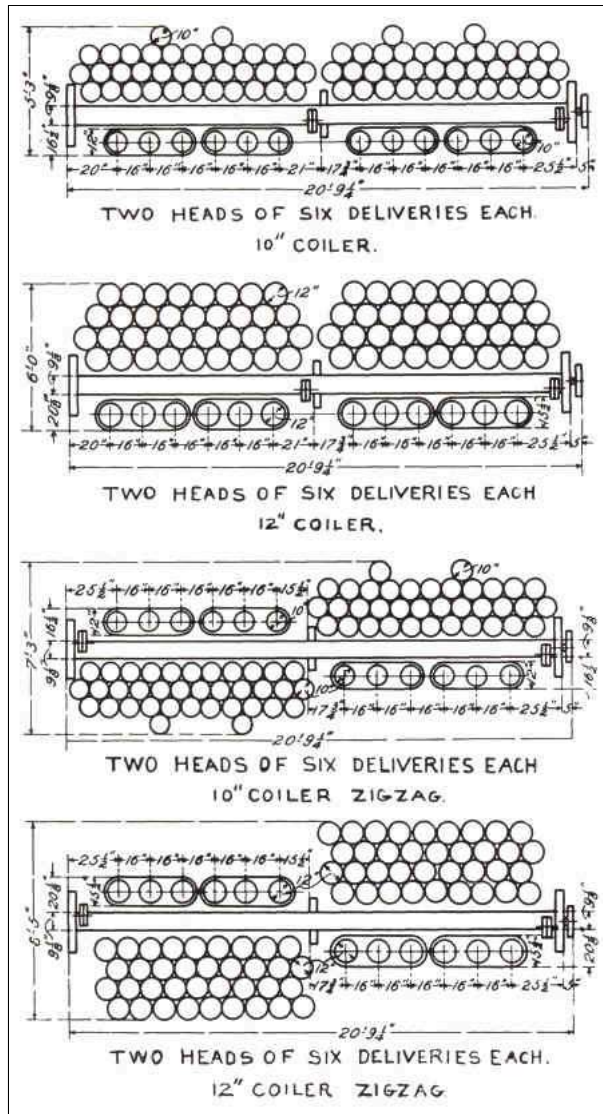

{90}

LENGTHS OF DRAWING FRAMES, 16-IN. GAUGE.

Number of Heads per Frame	Number of Deliveries per Head							
	2	3	4	5	6	7	8	
1	5'-6 1/2"	6'-10 1/2"	8'-2 1/2"	9'-6 1/2"	10'-10 1/2"	12'-2 1/2"	13'-6 1/2"	
2	10'-1 1/4"	12'-9 1/4"	15'-5 1/4"	18'-1 1/4"	20'-9 1/4"	23'-5 1/4"	26'-1 1/4"	
3	14'-8"	18'-8"	22'-8"	26'-8"	30'-8"	34'-8"	38'-8"	
4	19'-2 3/4"	24'-6 3/4"	29'-10 3/4"	35'-2 3/4"	40'-6 3/4"	45'-10 3/4"	51'-2 3/4"	
5	23'-9 1/2"	30'-5 1/2"	37'-1 1/2"	43'-9 1/2"	50'-5 1/2"	57'-1 1/2"	63'-9 1/2"	
6	28'-4 1/4"	36'-4 1/4"	44'-4 1/4"	52'-4 1/4"	60'-4 1/4"	68'-4 1/4"	76'-4 1/4"	
7	32'-11"	42'-8"	51'-7"	60'-11"	70'-8"	79'-7"	88'-11"	
8	37'-5 3/4"	48'-1 3/4"	58'-9 3/4"	69'-5 3/4"	80'-1 3/4"	90'-9 3/4"	101'-5 3/4"	
Add for each Additional Head	4'-6 3/4"	5'-10 3/4"	7'-2 3/4"	8'-6 3/4"	9'-10 3/4"	11'-2 3/4"	12'-6 3/4"	

Above lengths are over all, including Driving Pulley.

For widths, see Floor Plans, [pages 88 and 89](#)

Drawing Frames are usually made with 4, 5 or 6 deliveries per head or table, and 2, 3 or 4 heads per frame, but can be made with more or less deliveries per head, and more or less heads per frame.

{91}

DRAWING FRAMES.

PRODUCTION PER DAY OF TEN HOURS.

	R. P. M. of 1 1/2" dia. Front Roll	Weight in grains of one yard of Sliver													
		35	40	45	50	55	60	65	70	75	80	85	90	95	100
		Lbs.	Lbs.	Lbs.	Lbs.	Lbs.	Lbs.	Lbs.	Lbs.	Lbs.	Lbs.	Lbs.	Lbs.	Lbs.	Lbs.
Common Rolls	250	75	85	96	106	117	128	138	149	160	170	181	192	202	213
	275	82	94	105	117	129	141	152	164	176	187	199	211	223	234
	300	89	102	115	128	141	153	165	179	192	204	217	230	243	256
	325	97	111	125	138	152	166	180	194	208	222	235	249	263	277
	350	104	119	134	149	164	179	194	209	224	239	253	268	283	298
	375	112	128	144	160	176	192	208	224	240	256	272	288	304	320
	400	119	136	153	170	187	204	222	239	256	273	290	307	324	341
	425	127	145	163	181	199	217	235	253	272	290	308	326	344	362
	450	134	153	173	192	211	230	249	268	288	307	326	345	364	383
	Metallic Rolls	250	99	113	127	141	155	169	183	197	211	225	239	253	267
275		108	124	139	155	170	186	201	217	232	248	263	279	294	310
300		118	135	152	169	186	203	220	236	253	270	287	304	321	338
325		128	146	165	183	201	220	238	256	274	293	311	329	348	366
350		138	158	177	197	217	236	256	276	296	315	335	355	374	394
375		148	169	190	211	232	253	274	295	317	338	359	380	401	422
400		158	180	203	225	248	270	293	315	338	360	383	405	428	450
425		167	191	215	239	263	287	311	335	359	383	407	431	455	479
450		177	203	228	253	279	304	329	355	380	405	431	456	481	507

NOTE—In the above table 20 per cent. has been deducted for stops, cleaning, etc.

{92}

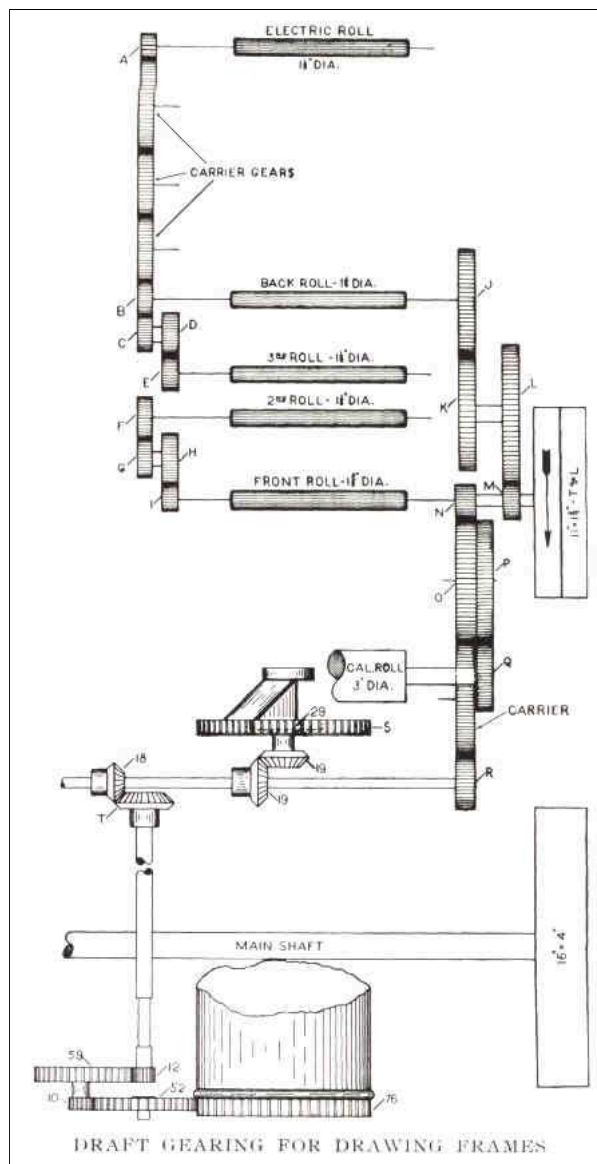

DRAFT GEARING FOR DRAWING FRAMES

{93}

DRAWING FRAMES.

ALPHABETICAL REFERENCES TO DIAGRAM.

- A Electric Roll Gear, 24 Teeth for Common Rolls, 20 Teeth for Metallic Rolls.
- B Off End Back Roll Gear. 24 Teeth for Common Rolls, 29 Teeth for Metallic Rolls.
- *C Small Double Intermediate, driving 3d Roll.
- D Large Double Intermediate, driving 3d Roll, 40 Teeth for Common Rolls, 36 Teeth for Metallic Rolls.
- E Off End 3d Roll Gear, 24 Teeth.
- *F Off End 2d Roll Gear.
- *G Small Double Intermediate, driving 2d Roll.
- *H Large Double Intermediate, driving 2d Roll.
- I Off End Front Roll Gear, 20 Teeth.
- J Back Roll Gear, 45 to 80 Teeth.
- K Draft Change Gear, 45 to 70 Teeth.
- *L Crown Gear.

- *M Front Roll Gear.
 N Front Roll Calender Driving Gear, 16 Teeth for Common Rolls, 19 Teeth for Metallic Rolls.
 O and P Double Intermediate Gear, 52 and 91 Teeth for 10-in. Coiler, 62 and 108 Teeth for 12-in. Coiler.
 Q Calender Roll Gear, 58, 59, 60 Teeth for Common Rolls, 52, 53, 54 Teeth for Metallic Rolls.
 R Coiler Horizontal Shaft Gear, 21 to 26 Teeth (driven by O through Carrier Gear).
 S Tube Wheel, 75 Teeth for 10-in. Coiler, 98 Teeth for 122 in. Coiler.
 T Coiler Vertical Shaft, Top Bevel Gear, 32 Teeth for 10 in. Coiler, 37 Teeth for 12-in. Coiler.

NOTE—For teeth on gears marked * refer to table on [page 96](#).

{94}

DRAWING FRAMES.

DRAFT CALCULATIONS.

Rules:

$$\frac{A \times J \times L \times N \times P \times \text{dia. of Calender Roll}}{B \times M \times O \times Q \times \text{dia. of Electric Roll}} = \text{Draft Constant}$$

$$\frac{\text{Draft Constant}}{\text{Draft Change Gear (K)}} = \text{Draft.}$$

$$\frac{\text{Draft Constant}}{\text{Draft required}} = \text{Draft Change Gear (K).}$$

Examples:

If Common Rolls and 10-in. Coilers. Back Roll Gear (J) = 68 T. Crown Gear (L) = 98 T. Front Roll Gear (M) = 22 T.

$$\frac{24 \times 68 \times 98 \times 16 \times 91 \times 3}{24 \times 22 \times 52 \times 59 \times 1\frac{1}{8} \text{ in.}} = 383.34 \text{ Draft Constant.}$$

If Draft Change Gear (K) = 64 T.

$$\frac{383.34}{64} = 5.99 = \text{Draft.}$$

If Draft required = 5.48

$$\frac{383.34}{5.48} = 70 \text{ T.} = \text{Draft Change Gear (K).}$$

The above figures are for Total Draft up to and including the 3-in. dia. Calender Rolls. When Graduated Pitch Metallic Rolls are used, and it is desired to figure drafts between them, the following equivalents are approximately correct:

- 1-3/8-in. dia. Roll, 32 pitch, taken as 11/6-in. or 1.83-in. dia.
 1-1/4-in. dia. Roll, 32 pitch, taken as 10/6-in. or 1.67-in. dia.
 1-1/8-in. dia. Roll, 32 pitch, taken as 9/6-in. or 1.50-in. dia.
 1-in. dia. Roll, 32 pitch, taken as 8/6-in. or 1.33-in. dia.
 1-1/8-in. dia. Roll, 16 pitch, taken as 10/6-in. or 1.67-in. dia.
 1-in dia. Roll, 16 pitch, taken as 9/6-in. or 1.50-in. dia.

{95}

PRODUCTION CALCULATIONS

Rule:

$$\frac{\text{R. P. M. of Front Roll} \times \text{N} \times \text{P} \times \text{Circum. of Cal. Roll} \times \text{Wt. of Sliver in grains} \times 600}{\text{O} \times \text{Q} \times 7,000 \text{ (grains in 1 lb.)} \times 36 \text{ (inches in 1 yd.)}} = \text{Lbs. in 10 hours.}$$

Examples:

If *Common Rolls*, R. P. M. of 1 $\frac{3}{8}$ -in. Front Roll = 350, Front Roll Calender Driving Gear (N) = 16 T., Double Intermediate Gear (O) = 52 T. and (P) = 91 T., Calender Roll Gear (Q) = 59 T., Circum. of 3-in. Cal. Roll = 9.425 in. Wt. of Sliver per yd. = 60 grains. Twenty per cent. allowance for stops, etc. 10-in. Coiler.

$$\frac{350 \times 16 \times 91 \times 9.425 \times 60 \times 600 \times .80}{52 \times 59 \times 7,000 \times 36} = 179 \text{ lbs in 10 hours.}$$

If *Metallic Rolls*, R. P. M. of 1 $\frac{3}{8}$ -in. Front Roll = 350, Front Roll Calender Driving Gear (N) = 19 T., Double Intermediate Gear (O) = 52 T. and (P) = 91 T., Calender Roll Gear (Q) = 53 T., Circum. of 3-in. Cal. Roll = 9.425 in. Wt. of Sliver per yd. = 60 grains. Twenty per cent. allowance for stops, etc. 10-in. Coiler.

$$\frac{350 \times 19 \times 91 \times 9.425 \times 60 \times 600 \times .80}{52 \times 53 \times 7,000 \times 36} = 236 \text{ lbs. in 10 hours.}$$

The greater production with Metallic Rolls over Common Rolls for a given number of revs. is due to the meshing of the flutes, which increases the effective circum. of the rolls about 33 per cent. This accounts for the difference in the gears driving the Calender Rolls.

Short rules for production in 10 hours based on 20 per cent. allowance for stops, etc., and 1-3/8 in. dia. front bottom roll.

Common Rolls—.852 x R. P. M. of Front Roll x Wt. of Sliver in grains = Lbs. in 10 hours.

Metallic Rolls—1.126 x R. P. M. of Front Roll x Wt. of Sliver in grains = Lbs. in 10 hours.

{96}

DRAWING FRAMES.

GEARING COMBINATIONS, DRAFT CONSTANTS AND DRAFTS FOR MACHINES WITH 1-3/8-IN. FRONT ROLL.

		Number of Teeth in Gears							Draft Constant with 10-in. Coiler	Total Draft with 10-in. Coiler	Draft Constant with 12-in. Coiler	Total Draft with 12-in. Coiler	
		C	F	G	H	J	K	L					M
Common Rolls		36	29	30	38	45	68	94	26	205.90	3.03	204.95	3.01
		36	29	30	38	45	63	94	26	205.90	3.27	204.95	3.25
		36	30	29	40	45	59	94	26	205.90	3.49	204.95	3.47
		36	30	29	40	45	55	94	26	205.90	3.74	204.95	3.73
		36	30	26	40	48	67	98	22	270.60	4.04	269.35	4.02
		36	30	26	40	48	63	98	22	270.60	4.30	269.35	4.28
		36	34	26	40	48	60	98	22	270.60	4.50	269.35	4.48
		36	34	26	40	48	57	98	22	270.60	4.75	269.35	4.73
		36	34	24	40	48	54	98	22	270.60	5.01	269.35	4.99
		36	34	24	40	48	51	98	22	270.60	5.30	269.35	5.28
		36	36	24	40	68	70	98	22	383.34	5.48	381.58	5.45
		36	36	24	40	68	67	98	22	383.34	5.72	381.58	5.70
		36	38	24	40	68	64	98	22	383.34	5.99	381.58	5.96
		36	38	24	40	68	61	98	22	383.34	6.28	381.58	6.25
		36	38	24	40	68	59	98	22	383.34	6.50	381.58	6.47
		36	38	24	40	68	57	98	22	383.34	6.73	381.58	6.70
Metallic Rolls (Graduated Pitch)		33	26	32	40	48	66	94	26	200.22	3.04	199.30	3.02
		33	26	32	40	48	61	94	26	200.22	3.28	199.30	3.26
		33	26	32	40	48	57	94	26	200.22	3.51	199.30	3.50
		33	26	32	40	48	53	94	26	200.22	3.78	199.30	3.76
		33	28	32	40	53	68	98	22	272.40	4.01	271.14	3.99
		33	28	32	40	53	64	98	22	272.40	4.26	271.14	4.24
		31	28	30	40	53	60	98	22	272.40	4.54	271.14	4.52
		31	28	30	40	53	57	98	22	272.40	4.78	271.14	4.76
		31	30	30	40	53	54	98	22	272.40	5.04	271.14	5.02
		31	30	30	40	66	64	98	22	339.20	5.30	337.64	5.28
		31	32	30	40	66	61	98	22	339.20	5.56	337.64	5.54
		31	32	30	40	66	59	98	22	339.20	5.75	337.64	5.73
		31	33	30	40	66	56	98	22	339.20	6.06	337.64	6.03
		31	33	30	40	66	54	98	22	339.20	6.28	337.64	6.25
		31	33	30	40	66	52	98	22	339.20	6.52	337.64	6.49
		31	33	28	40	66	50	98	22	339.20	6.78	337.64	6.75

The above constant and drafts are figured up to and including the 3-in. Calender Rolls. Draft Gear K is the usual change gear.

When making extreme draft changes the best results will be obtained by following the above arrangements of gearing.

{97}

TABLE FOR NUMBERING CARD OR DRAWING SLIVERS.

Grains per Yard	Hank	Grains per Yard	Hank	Grains per Yard	Hank	Grains per Yard	Hank
30	.278	48	.174	66	.126	84	.099
31	.269	49	.170	67	.124	85	.098
32	.260	50	.167	68	.122	86	.097
33	.252	51	.163	69	.121	87	.096
34	.245	52	.160	70	.119	88	.095
35	.238	53	.157	71	.117	89	.094
36	.232	54	.154	72	.116	90	.093
37	.225	55	.151	73	.114	91	.092
38	.219	56	.149	74	.113	92	.091
39	.214	57	.146	75	.111	93	.090
40	.208	58	.144	76	.110	94	.089
41	.203	59	.141	77	.108	95	.088
42	.198	60	.139	78	.107	96	.087
43	.194	61	.137	79	.105	97	.086
44	.189	62	.134	80	.104	98	.085
45	.185	63	.132	81	.103	99	.084
46	.181	64	.130	82	.102	100	.083
47	.177	65	.128	83	.100		

8.333/Wt. in grains of 1 yd. of Sliver = Hank.
 8.333/Hank = Wt. in grains of 1 yd. of Sliver.
 100/Wt. in grains of 12 yds. of Sliver = Hank.
 Refer to *Table of Dividends*, [page 233](#).

{98}

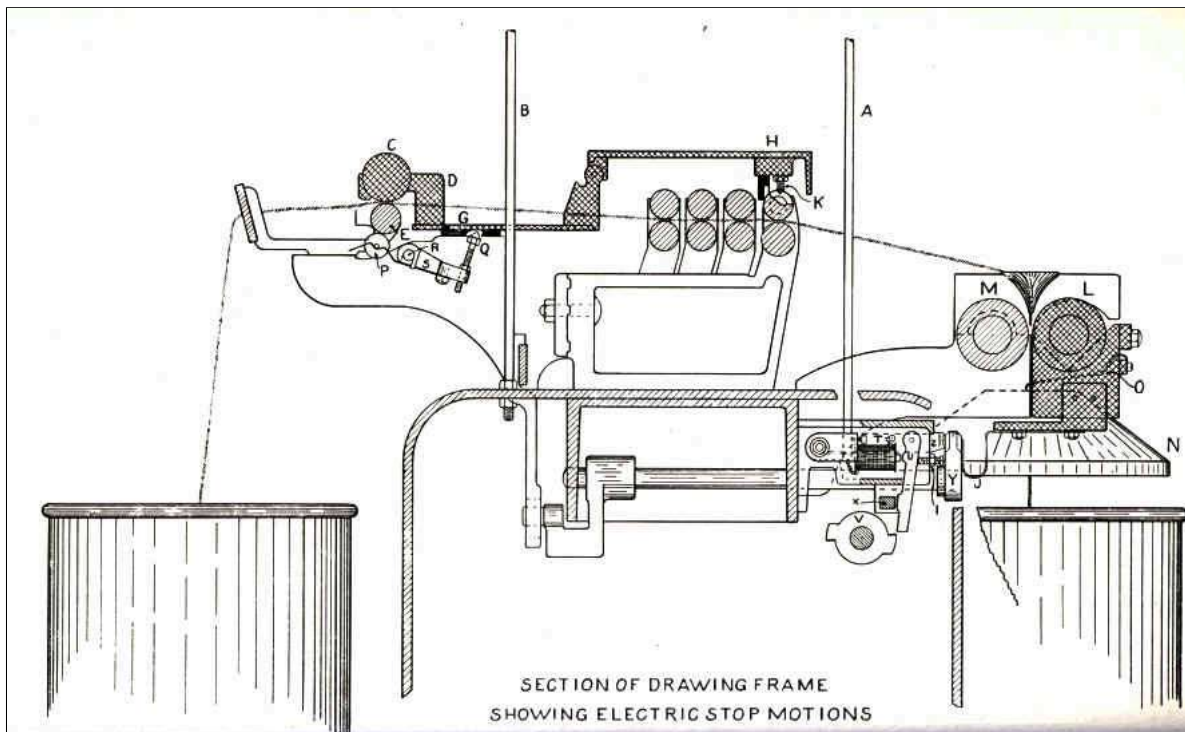

SECTION OF DRAWING FRAME

{99}

EXPLANATION OF ELECTRIC STOP MOTIONS.

Our improved Magneto or Dynamo for producing current to operate the Stop Motions is designed on the "Induction" principle, so that the current is generated in the stationary winding, and no brushes or collectors are needed. This type of machine is very simple, requires little attention, and gives a steady current, no matter how much dirt, lint or oil collects on same.

The Drawing Frame is divided into two parts by means of insulations (indicated by the solid black portions of cut on [opposite page](#)). One part, shown with double cross lines, is connected to the Magneto through the down-rod A, and the other part through the down-rod B.

It will be seen that in the case of each Stop Motion the parts are kept from touching each other by cotton passing between them (cotton being a non-conductor of electricity) or are brought into contact with each other by rollers lapping up or by the pressure of the cotton in the full cans.

The machine stops when the electric circuit is completed, allowing the current to flow through Magnet T, which attracts finger U into engagement with Revolving Clutch V, and by a mechanical arrangement shifts the belt on to the loose pulley.

As the frame stops, the part X forces the finger U away from the Clutch, and the current is broken by the piece Y which moves out of contact with the spring Z. When the frame is running, Y is in contact with both the springs Z and J. As the machine stops, the movement of Y takes it out of contact with Z, but J should always press against Y.

{100}

STOP MOTION No. 1—C is the top electric roll which rests in Cap Bar D, and E is the bottom electric roll. As long as the sliver remains between the rolls they are kept apart and there is no circuit. When the sliver breaks or a can runs out the rolls come together and the frame knocks off.

STOP MOTION No.2—The Top Clearer Cover H has a screw K on the under side. If the cotton laps around the top or bottom front roll, the top roll is lifted and comes in contact with screw K, which completes the circuit and the machine stops.

STOP MOTION No. 3—The cotton sliver prevents the calender rolls L and M from touching each other. If the sliver breaks, the rolls touch and the machine stops instantly.

STOP MOTION No. 4—When the cans at the front are full and cotton presses against the coiler top N, it is lifted into contact with the spring O, and the circuit is completed, stopping the machine.

STOP MOTION No.5—The Underclearer P presses against the bottom electric roll E. In case the cotton laps around E or P, the screw Q is lifted and touches the Back Plate G, completes the circuit and the frame knocks off.

{101}

{102}

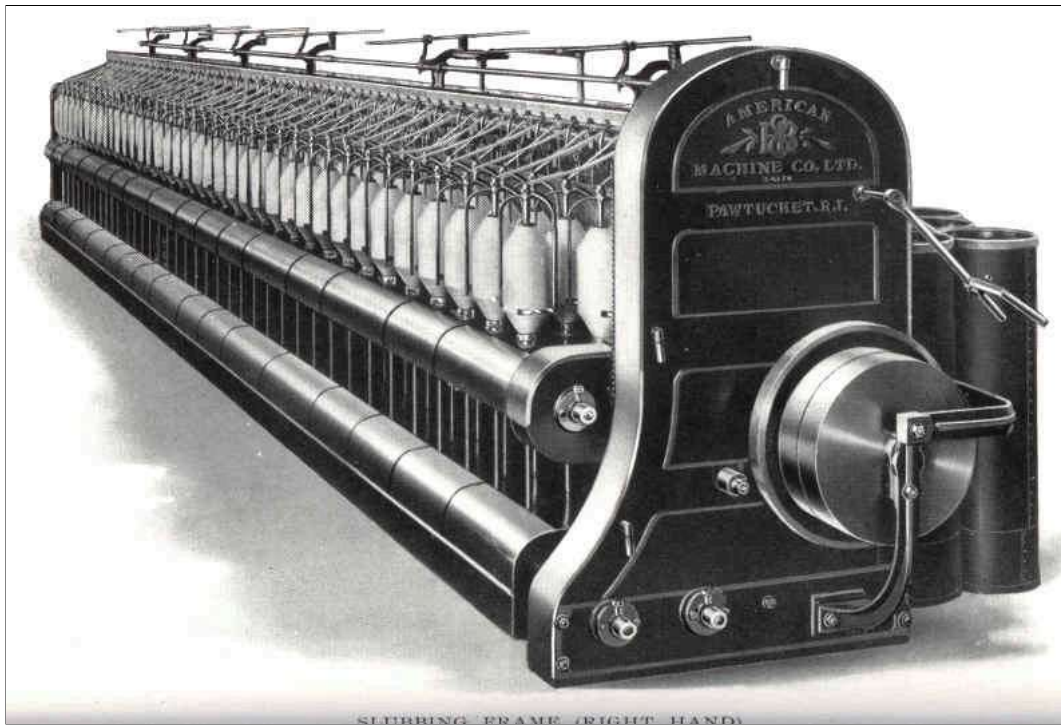

SLUBBING FRAME (RIGHT HAND)

{103}

SLUBBING, INTERMEDIATE, ROVING AND JACK FRAMES.

These frames are so well known to the users of Cotton Machinery that no general description is necessary. They have extra heavy framing, are made entirely by special tools, and all parts are exact duplicates. They are of superior construction and finish, and will stand the highest speeds without vibration or breakage. They contain many valuable patented improvements, some of which are described below.

PATENT SWING—Well supported and with one (large) Carrier Gear only.

IMPROVED DIFFERENTIAL MOTION—This motion effects a great saving in power, wear and tear, and gives more accurate winding and consequently evener and better work. See [page 106](#).

IMPROVED LAY GEARING dispenses with all bevel change gears, gives two change places instead of one, is simple and convenient, and allows free access to the main gearing. See [page 109](#).

IMPROVED METHOD OF LIFTING AND LOWERING BOTTOM CONE DRUM—Both ends of the cone are raised or lowered together from the front of the machine. The belt is kept at a uniform tension from one end of the cone to the other. A patent locking device secures the cone in its proper working position, after doffing, preventing all movement or vibration.

IMPROVED METHOD OF TIGHTENING THE CONE BELT does away with frequent taking-up. When slack, the belt may be tightened in a few moments by means of a Quadrant Bracket. Over 5 in. of stretch can be taken care of without re-piecing. A great saving is effected in labor, stoppages and cone belts.

WINDING BACK THE RACK AND CONE BELT is done from the front of the machine.

IMPROVED SYSTEM OF BALANCING THE TOP OR BOBBIN RAIL—This rail, with its gearing, collars, bobbins, etc., is now supported under its center of gravity by a set of levers, thus relieving the slides and racks of this weight. This system prevents friction and wear of slides, also the tendency to dwell at the changes of the traverse both top and bottom.

{104}

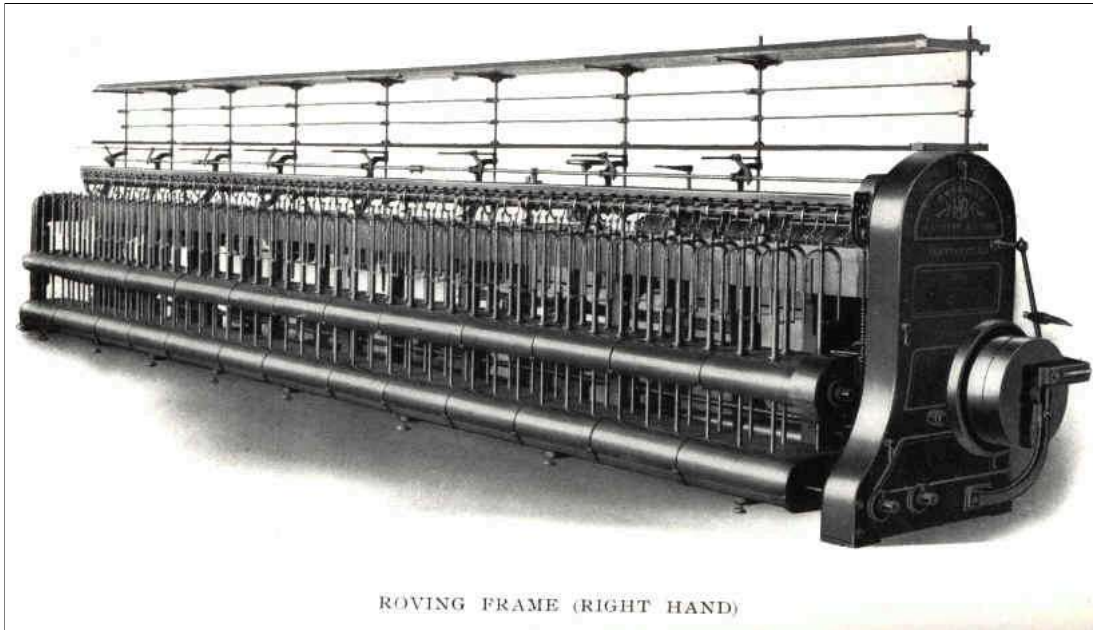

ROVING FRAME (RIGHT HAND)

{105}

If slides wear, the Long Collars tilt forward, the top rail, spindles, bobbins and flyers vibrate, causing bad work and loss of production. This is prevented by our improved system.

PATENT REVERSING AND LET-OFF MOTION entirely prevents the roving running over the ends on the changes. The speed of the bobbin changes simultaneously with the reversal of the lifting rail and thus overcomes the liability of stretching the roving.

FULL BOBBIN STOP MOTION is very effective in its action and prevents overfilling the bobbins. The frame cannot be started after the completion of a set until doffed and the rack has been wound back.

IMPROVED TOP CLEARERS—These are made of polished steel, very light and easy to clean. The hinging is so arranged that any clearer can be easily removed.

LONG COLLARS OR BOLSTERS are fastened in a vertical position by an improved method which prevents their working loose. They are bored throughout their entire length, thus reducing the liability of dirt accumulating inside and causing the spindles to bind.

PATENT RECESSED SELF-LUBRICATING SPINDLE FOOT—This has proved one of the most successful inventions, and is in extensive use. It ensures constant lubrication, prevents wear, and is easily kept clean.

BEARINGS INLAID WITH BRASS—All Bobbin and Spindle Shaft Bearings, Roller Stands and Slides are inlaid with brass.

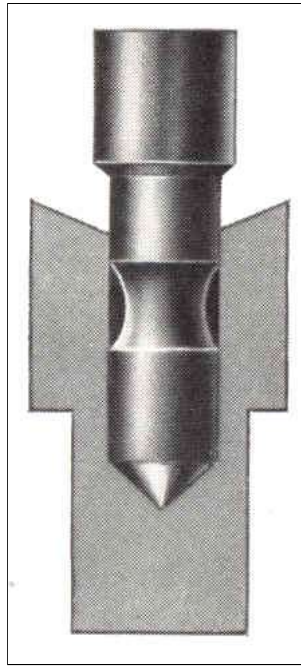

DRIVING ENDS OF BOBBIN AND SPINDLE SHAFTS are case hardened and are in short lengths, so that they can be easily taken out even when frames are placed end to end with narrow passages between them. This is a great convenience, as it avoids the necessity of having to remove a great many shaft gears. The shafts can be lifted out with the gears on them.

AUTOMATIC PANEL LOCKING ARRANGEMENT prevents the frame from being started if any of the gearing end panels are not in place.

{106}

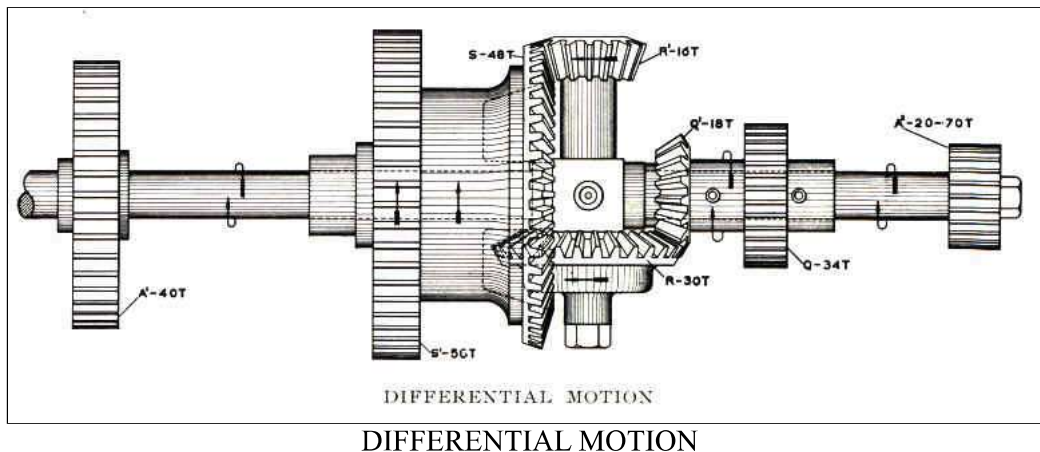

{107}

IMPROVED DIFFERENTIAL MOTION.

All the gears on the Jack Shaft revolve in the same direction as the shaft itself. This reduces considerably the work the cone belt has to do, saves power, and gives more accurate winding and evener and better work.

A^1 (40 teeth) drives the Spindle Shafts and S^1 (50 teeth) drives the Bobbin Shafts. The gears on the Spindle and Bobbin Shafts are alike, i. e., they have the same number of teeth.

As the cut shows the number of teeth in all the gears of the Differential, it will readily be seen that if Q and Q^1 are held stationary, the speed of S^1 will be retarded 1 rev. for every 5 revs. the Jack Shaft makes, and the spindles and bobbins will be running at the same speed, no winding taking place. Winding is produced by the bobbins running faster than the

spindles, therefore Q, which is driven from the bottom cone through carrier gears, must revolve. Its speed changes as the bobbins increase in diameter, being governed by the position of the cone belt, which is shifted slightly as each layer is put on the bobbins.

{108}

CASING-OFF PLATES—The Front Casing-off Plates for Bobbin and Spindle Shafts are made of polished steel and are circular in shape. They are light, strong, cannot be broken, and are easily kept clean.

IMPROVED CAP BARS—Cast-iron Cap Bars give trouble on account of the fingers being twisted, and frequent breakages. The illustrations show the construction of our improved Cap Bar, which entirely obviates these difficulties. Figure 1 is a back view of our Cap Bar applied to a machine with four spindles in a box, and Figure 2 an end view of same. Figures 3, 4 and 5 show enlarged details.

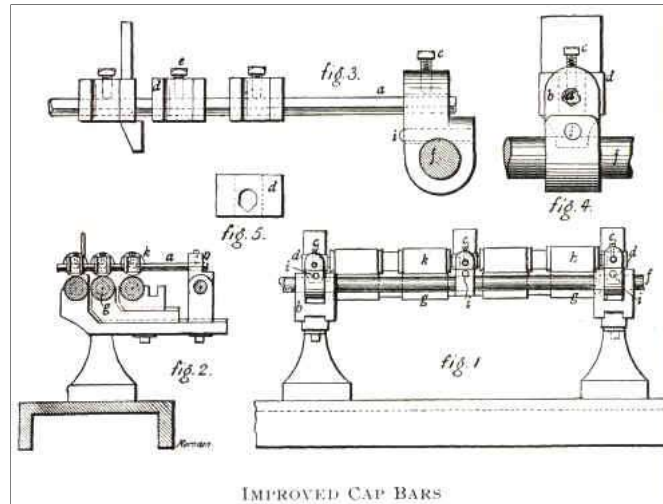

IMPROVED CAP BARS

The Cap Bars are fastened to the Roller Stands by brackets which are independent of the slides, and consequently the rolls can be set without moving the Cap Bars. When resetting the rolls it is only necessary to adjust the nebs for the middle and back lines, as the front nebs do not have to be disturbed.

{109}

IMPROVED LAY GEARING.

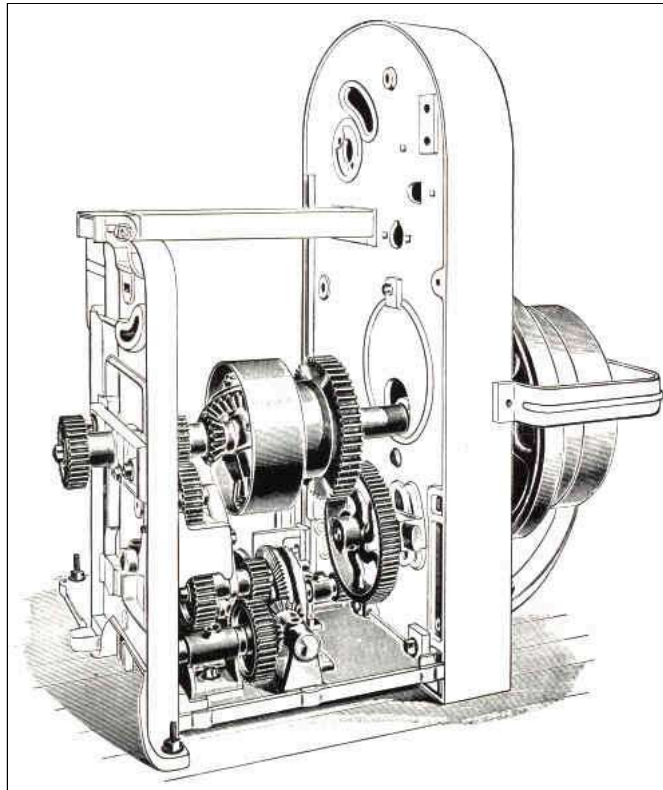

To facilitate making changes in the Lay Gears, we have provided two change places instead of one. Formerly it was the practice to change the gear on the end of the Reversing Shaft or the one between the Reversing Bevels.

In order to bring the change gears into a more convenient position and at the same time increase the range, we have introduced two additional spur gears. One of these is now the regular change gear, and is on a stud carried by an adjustable Quadrant Bracket. The short shaft carrying the bevel gears is now in a horizontal position instead of vertical.

{110}

Besides providing for two change places, this improvement dispenses with the Back Cross Rail and allows free access to the main gearing. Any part of the gearing can be taken out and replaced with ease.

There is no longer any necessity of changing any bevel gears. There are two spur gear changes, either of which may be used and which give a very wide range. The entire arrangement is very simple and convenient.

USUAL ROLLER WEIGHTS.			
	Front	Middle	Back
Slubbing Frame, single boss rolls	18	14	10
Intermediate Frame, single boss rolls	14	10	8
Roving Frame, single boss rolls	10	8	6
Roving Frame, double boss rolls	18	14	12

STANDARD DIMENSIONS.				
	Slub.	Inter.	Rov.	Jack
Dia. of Spindles	$\frac{3}{4}$	$\frac{3}{4}$	$\frac{5}{8}$	$\frac{5}{8}$
Dia. of Long Collars	$1\frac{1}{8}$	$1\frac{1}{8}$	1	1
Dia. of Bobbin Gear Tops	$1\frac{1}{4}$	$1\frac{1}{4}$	$1\frac{1}{8}$	$1\frac{1}{8}$
Dia. of Front Bottom Roll	$1\frac{1}{4}$	$1\frac{1}{4}$	$1\frac{1}{8}$	$1\frac{1}{8}$
Dia. of Middle Bottom Roll	1	1	1	1
Dia. of Back Bottom Roll	$1\frac{1}{4}$	$1\frac{1}{4}$	$1\frac{1}{8}$	$1\frac{1}{8}$
Dia. of Top Rolls on iron	1	1	1	1

Other sizes of Spindles, Long Collars, Bobbin Gear Tops and Rolls will be supplied when necessary.

DRIVING PULLEYS are usually 16 in. dia., 3 in. face.

SPEEDS—See [pages 111](#) and [112](#).

PRODUCTION—See [pages 113 to 117](#).

{111}

SPEED TABLE.

SLUBBING AND INTERMEDIATE FRAMES

R. P. M. of Driving Pulley	R. P. M. of Spindles	R. P. M. of Driving Pulley	R. P. M. of Spindles	R. P. M. of Driving Pulley	R. P. M. of Spindles
300	523.80	395	689.68	490	855.55
305	532.54	400	698.41	495	864.28
310	541.27	405	707.14	500	873.01
315	550.00	410	715.87	505	881.73
320	558.73	415	724.60	510	890.46
325	567.46	420	733.33	515	899.19
330	576.19	425	742.06	520	907.92
335	584.92	430	750.79	525	916.65
340	593.65	435	759.52	530	925.38
345	602.38	440	768.25	535	934.11
350	611.11	445	776.98	540	942.84
355	619.84	450	785.71	545	951.57
360	628.57	455	794.44	550	960.30
365	637.30	460	803.17	555	969.03
370	646.03	465	811.90	560	977.76
375	654.76	470	820.63	565	986.49
380	663.49	475	829.36	570	995.22
385	672.22	480	838.09	575	1003.95
390	680.95	485	846.82	580	1012.68

One rev. of Driving Pulley = 1.746 revs. of Spindles.

USUAL SPEEDS.

	Size of Bobbin	Revs. of Spindles	Revs. of Driving Pulley
Slubbing Frame . . .	12 x 6	630	361
Slubbing Frame . . .	11 x 5½	700	401
Slubbing Frame . . .	10 x 5¼	750	430
Intermediate Frame .	10 x 5	850	487
Intermediate Frame .	9 x 4¾	950	544
Intermediate Frame .	9 x 4⅝	1000	573

{112}

SPEED TABLE.

ROVING AND JACK FRAMES.

R. P. M. of Driving Pulleys	R. P. M. of Spindles	R. P. M. of Driving Pulley	R. P. M. of Spindles	R. P. M. of Driving Pulley	R. P. M. of Spindles
336	908.10	412	1113.51	488	1318.92
340	918.92	416	1124.32	492	1329.73
344	929.73	420	1135.13	496	1340.54
348	940.54	424	1145.94	500	1351.35
352	951.35	428	1156.75	504	1362.16
356	962.16	432	1167.56	508	1372.97
360	972.97	436	1178.37	512	1383.78
364	983.78	440	1189.18	516	1394.59
368	994.59	444	1200.00	520	1405.41
372	1005.40	448	1210.81	524	1416.22
376	1016.21	452	1221.62	528	1427.03
380	1027.02	456	1232.43	532	1437.84
384	1037.83	460	1243.24	536	1448.65
388	1048.64	464	1254.05	540	1459.46
392	1059.45	468	1264.86	544	1470.27
396	1070.27	472	1275.67	548	1481.08
400	1081.08	476	1286.48	552	1491.89
404	1091.89	480	1297.30	556	1502.70
408	1102.70	484	1308.11	560	1513.51

One rev. of Driving Pulley = 2.7027 revs. of Spindles.

USUAL SPEEDS.

	Size of Bobbin	Revs. of Spindles	Revs. of Driving Pulley
Roving Frame	8 x 4	1050	388
Roving Frame	8 x 3 $\frac{3}{8}$	1100	408
Roving Frame	7 x 3 $\frac{1}{2}$	1150	426
Roving Frame	7 x 3 $\frac{1}{4}$	1200	520
Jack Frame	6 x 3 $\frac{1}{4}$	1250	463
Jack Frame	6 x 3	1300	481
Jack Frame	6 x 2 $\frac{3}{4}$	1350	500
Jack Frame	6 x 2 $\frac{1}{2}$	1400	518

{113}

SLUBBING FRAMES.

PRODUCTION PER DAY OF TEN HOURS.

Size of Bobbin . . .		12 x 6 in.				11 x 5½ in.			
Cotton on Full Bobbin		44-oz.				32-oz.			
Revs. of Spindle .		630				700			
Revs. of Pulley . .		361				401			
Dia. of Bot. Front Roll .		1¼-in.				1¼-in.			
Hank Roving	Twist per In.	Revs. Front Roll	Sets per Day	Hanks per Day	Lbs. per Day	Revs. Front Roll	Sets per Day	Hanks per Day	Lbs. per Day
.20	.54	297	20.51	11.28	56.40				
.25	.60	267	17.24	11.85	47.41				
.30	.66	243	14.59	12.03	40.11	270	18.69	11.21	37.38
.35	.71	226	12.55	12.08	34.52	251	16.45	11.52	32.90
.40	.76	211	10.88	11.97	29.93	234	14.54	11.63	29.08
.45	.80	201	9.60	11.83	26.39	223	13.02	11.71	26.04
.50	.85	189	8.44	11.61	23.21	210	11.60	11.60	23.20
.55	.89	180	7.54	11.40	20.72	200	10.47	11.52	20.94
.60	.93	173	6.77	11.17	18.61	192	9.49	11.38	18.98
.65	.97	165	6.11	10.92	16.80	184	8.64	11.23	17.28
.70	1.00	160	5.59	10.75	15.36	178	7.95	11.13	15.90
.75	1.04	154	5.09	10.49	13.99	171	7.28	10.92	14.56
.80	1.07	150	4.69	10.31	12.89	166	6.75	10.80	13.50
.85	1.11	145	4.30	10.05	11.82	160	6.22	10.57	12.44
.90	1.14	141	3.99	9.87	10.97	156	5.79	10.42	11.58
.95	1.17	137	3.71	9.69	10.20	152	5.41	10.28	10.82
1.00	1.20	134	3.46	9.52	9.52	148	5.06	10.12	10.12
1.05	1.23	145	4.74	9.95	9.48
1.10	1.26	141	4.45	9.79	8.90
1.15	1.29	138	4.19	9.64	8.38
1.20	1.31	136	3.98	9.55	7.96

NOTE—The above table is based on ordinary twist, 1.20 x square root of hank, with an allowance of 15 minutes per set for doffing and stops.

{114}

**INTERMEDIATE FRAMES.
PRODUCTION PER DAY OF TEN HOURS.**

Size of Bobbin . . .		10 x 5 In.				9 x 4 ⁵ / ₈ In.			
Cotton on Full Bobbin		24-oz.				18-oz.			
Revs. of Spindle .		850				950			
Revs. of Pulley .		487				544			
Dia. of Bot. Front Roll .		1 ¹ / ₄ -in.				1 ¹ / ₄ -in.			
Hank Roving	Twist per in.	Revs. Front Roll	Sets per Day	Hanks per Day	Lbs. per Day	Revs. Front Roll	Sets per Day	Hanks per Day	Lbs. per Day
.60	.93	223	13.40	12.06	20.10				
.65	.97	223	12.33	12.03	18.50				
.70	1.00	216	11.46	12.03	17.19				
.75	1.04	208	10.67	12.00	16.00				
.80	1.07	202	9.89	11.87	14.84				
.85	1.11	195	9.18	11.70	13.77				
.90	1.14	190	8.60	11.61	12.90	212	11.60	11.75	13.05
.95	1.17	185	8.07	11.50	12.11	207	10.95	11.70	12.32
1.00	1.20	180	7.59	11.39	11.39	202	10.35	11.64	11.64
1.05	1.23	176	7.15	11.27	10.73	197	9.80	11.53	11.03
1.10	1.26	172	6.75	11.14	10.13	192	9.28	11.43	10.44
1.15	1.29	168	6.37	10.99	9.56	187	8.81	11.40	9.91
1.20	1.31	165	6.07	10.83	9.11	184	8.42	11.36	9.47
1.25	1.34	161	5.75	10.79	8.63	180	8.00	11.25	9.00
1.30	1.37	158	5.45	10.63	8.18	176	7.62	11.13	8.56
1.35	1.39	156	5.21	10.56	7.82	174	7.30	11.08	8.21
1.40	1.42	152	4.96	10.42	7.44	170	6.96	10.96	7.83
1.45	1.44	150	4.75	10.34	7.13	168	6.68	10.90	7.52
1.50	1.47	147	4.52	10.17	6.78	164	6.39	10.79	7.19
1.55	1.49	145	4.34	10.09	6.51	162	6.14	10.71	6.91
1.60	1.52	142	4.14	9.94	6.21	159	5.88	10.59	6.62
1.65	1.54	140	3.98	9.85	5.97	157	5.66	10.51	6.37
1.70	1.56	139	3.83	9.78	5.75	155	5.46	10.44	6.14
1.75	1.59	152	5.23	10.29	5.88
1.80	1.61	150	5.05	10.22	5.68
1.90	1.65	147	4.71	10.07	5.30
2.00	1.70	142	4.39	9.88	4.94
2.10	1.74	139	4.11	9.70	4.62
2.20	1.78	136	3.87	9.57	4.35
2.30	1.82	133	3.64	9.41	4.09
2.40	1.86	130	3.43	9.26	3.86
2.50	1.90	127	3.24	9.13	3.65

NOTE—The above table is based on ordinary twist, 1.20 x square root of hank, with an allowance of 15 minutes per set for doffing and stops.

{115}

ROVING FRAMES.

PRODUCTION PER DAY OF TEN HOURS

Size of Bobbin . . .		8 x 4 in.				8 x 3½ in.			
Cotton on Full Bobbin		14-oz.				12-oz.			
Revs. of Spindle .		1,050				1,100			
Revs. of Pulley . .		388				408			
Dia. of Bot. Front Roll		1⅛-in.				1⅛-in.			
Hank Roving	Twist per In.	Revs. Front Roll	Sets per Day	Hanks per Day	Lbs. per Day	Revs. Front Roll	Sets per Day	Hanks per Day	Lbs. per Day
1.20	1.31	227	10.99	11.53	9.61				
1.30	1.37	217	10.02	11.40	8.77				
1.40	1.42	209	9.22	11.30	8.07				
1.50	1.47	202	8.50	11.16	7.44	212	9.92	11.16	7.44
1.60	1.52	195	7.87	11.01	6.88	205	9.21	11.06	6.91
1.70	1.56	190	7.33	10.91	6.42	200	8.61	10.98	6.46
1.80	1.61	185	6.82	10.73	5.96	193	8.03	10.84	6.02
1.90	1.65	180	6.38	10.62	5.59	189	7.53	10.74	5.65
2.00	1.70	175	5.96	10.42	5.21	183	7.05	10.58	5.29
2.10	1.74	171	5.60	10.29	4.90	179	6.64	10.46	4.98
2.20	1.78	167	5.28	10.16	4.62	175	6.27	10.34	4.70
2.30	1.82	163	4.98	10.03	4.36	171	5.92	10.21	4.44
2.40	1.86	160	4.71	9.89	4.12	167	5.61	10.08	4.20
2.50	1.90	156	4.45	9.75	3.90	164	5.31	9.95	3.98
2.60	1.93	154	4.24	9.65	3.71	161	5.07	9.88	3.80
2.70	1.97	151	4.03	9.50	3.52	159	4.81	9.75	3.61
2.80	2.01	148	3.83	9.38	3.35	155	4.58	9.60	3.43
2.90	2.04	146	3.66	9.28	3.20	153	4.38	9.54	3.29
3.00	2.08	143	3.48	9.15	3.05	150	4.18	9.39	3.13
3.10	2.11	141	3.34	9.05	2.92	148	4.00	9.30	3.00
3.20	2.15	138	3.19	8.93	2.79	145	3.83	9.18	2.87
3.30	2.18	136	3.06	8.84	2.68	143	3.67	9.11	2.76
3.40	2.21	134	2.94	8.74	2.57	141	3.53	9.01	2.65
3.50	2.24	133	2.82	8.65	2.47	139	3.40	8.93	2.55
3.75	2.32	128	2.56	8.40	2.24	134	3.09	8.70	2.32
4.00	2.40	124	2.34	8.20	2.04	130	2.82	8.48	2.12
4.25	2.47	120	2.15	8.00	1.88	128	2.59	8.25	1.94
4.50	2.55	117	1.97	7.74	1.72	122	2.38	8.06	1.79
4.75	2.62	113	1.83	7.60	1.60	119	2.21	7.88	1.66
5.00	2.68	111	1.70	7.45	1.49	116	2.06	7.75	1.55
5.25	2.75	113	1.92	7.56	1.44
5.50	2.81	111	1.80	7.43	1.35
5.75	2.88	108	1.68	7.24	1.26
6.00	2.94	106	1.58	7.14	1.19

NOTE—The above table is based on ordinary twist, 1.20 x square root of hank, with an allowance of 15 minutes per set for doffing and stops.

{116}

ROVING FRAMES. PRODUCTION PER DAY OF TEN HOURS.

Size of Bobbin		7 x 3½ In.				7 x 3⅛ In.			
Cotton on Full Bobbin		10-oz.				9-oz.			
Revs. of Spindle . . .		1,150				1,200			
Revs. of Pulley . . .		426				520			
Dia. of Bot. Front Roll .		1⅛-in.				1⅛-in.			
Hank Rov-ing	Twist per In.	Revs. Front Roll	Sets per Day	Hanks per Day	Lbs. per Day	Revs. Front Roll	Sets per Day	Hanks per Day	Lbs. per Day
2.00	1.70	191	8.47	10.58	5.29				
2.25	1.80	181	7.36	10.35	4.60				
2.50	1.90	171	6.45	10.08	4.08				
2.75	1.99	164	5.72	9.85	3.58				
3.00	2.08	156	5.10	9.57	3.19				
3.25	2.16	151	4.60	9.36	2.88				
3.50	2.24	145	4.17	9.14	2.61	152	4.76	9.38	2.68
3.75	2.32	140	3.80	8.98	2.38	146	4.34	9.15	2.44
4.00	2.40	136	3.47	8.68	2.17	142	3.97	8.92	2.23
4.25	2.47	132	3.20	8.50	2.00	137	3.66	8.76	2.08
4.50	2.54	128	2.96	8.33	1.85	134	3.39	8.60	1.91
4.75	2.60	125	2.75	8.17	1.72	131	3.16	8.46	1.78
5.00	2.68	121	2.55	7.95	1.59	127	2.98	8.25	1.65
5.25	2.75	118	2.38	7.82	1.49	123	2.73	8.09	1.54
5.50	2.81	116	2.23	7.70	1.40	121	2.56	7.92	1.44
5.75	2.88	113	2.09	7.53	1.31	118	2.40	7.76	1.35
6.00	2.94	111	1.97	7.38	1.23	115	2.25	7.62	1.27
6.25	3.00	108	1.86	7.25	1.16	113	2.14	7.50	1.20
6.50	3.06	106	1.76	7.15	1.10	111	2.02	7.41	1.14
6.75	3.12	104	1.66	7.02	1.04	109	1.91	7.22	1.07
7.00	3.17	103	1.58	6.93	.99	107	1.82	7.14	1.02
7.25	3.23	101	1.50	6.82	.94	105	1.73	7.03	.97
7.50	3.29	99	1.43	6.68	.89	103	1.64	6.90	.92
7.75	3.34	102	1.57	6.82	.88
8.00	3.39	100	1.50	6.72	.84
8.50	3.50	97	1.37	6.53	.77
9.00	3.60	94	1.27	6.39	.71
9.50	3.70	92	1.17	6.27	.66
10.00	3.79	90	1.09	6.10	.61

NOTE—The above table is based on ordinary twist, 1.20 x square root of hank, with an allowance of 15 minutes per set for doffing and stops.

{117}

JACK FRAMES.

PRODUCTION PER DAY OF TEN HOURS.

Size of Bobbin		6 x 3 In.				6 x 2½ In.			
Cotton on Full Bobbin		7-oz.				5-oz.			
Revs. of Spindle . .		1,300				1,400			
Revs. of Pulley . .		481				518			
Dia. of Bot. Roll Front		1⅛-in.				1⅛-in.			
Hank Roving	Twist per In.	Revs. Front Roll	Sets per Day	Hanks per Day	Lbs. per Day	Revs. Front Roll	Sets per Day	Hanks per Day	Lbs. per Day
5.00	2.68	137	3.96	8.65	1.73				
5.25	2.75	134	3.71	8.51	1.62				
5.50	2.81	131	3.48	8.36	1.52				
5.75	2.88	128	3.27	8.22	1.43				
6.00	2.94	125	3.08	8.10	1.35				
6.25	3.00	123	2.92	8.00	1.28				
6.50	3.06	120	2.76	7.87	1.21				
6.75	3.12	118	2.62	7.76	1.15				
7.00	3.17	116	2.49	7.63	1.09				
7.25	3.23	114	2.37	7.54	1.04				
7.50	3.29	112	2.25	7.39	.985				
7.75	3.34	110	2.16	7.32	.945				
8.00	3.39	109	2.06	7.21	.901	117	3.03	7.58	.947
8.50	3.50	105	1.89	7.03	.827	113	2.78	7.39	.869
9.00	3.60	102	1.74	6.85	.761	110	2.57	7.23	.803
9.50	3.70	99	1.61	6.69	.704	107	2.38	7.07	.744
10.00	3.79	97	1.50	6.56	.656	105	2.22	6.94	.694
10.50	3.89	95	1.39	6.38	.608	102	2.06	6.76	.644
11.00	3.98	92	1.30	6.26	.569	100	1.93	6.63	.603
11.50	4.07	91	1.22	6.14	.534	97	1.81	6.50	.566
12.00	4.16	89	1.15	6.04	.508	95	1.70	6.36	.531
12.50	4.24	87	1.08	5.91	.473	93	1.61	6.29	.503
13.00	4.33	85	1.02	5.80	.446	91	1.52	6.18	.475
13.50	4.41	83	.97	5.72	.424	90	1.44	6.08	.450
14.00	4.49	82	.92	5.64	.403	88	1.37	5.99	.428
15.00	4.65	79	.83	5.45	.363	85	1.24	5.82	.388
16.00	4.80	77	.75	5.25	.328	83	1.12	5.60	.350
17.00	4.95	74	.69	5.13	.302	80	1.03	5.47	.322
18.00	5.09	72	.63	4.97	.276	78	.95	5.35	.297
19.00	5.23	70	.58	4.83	.254	76	.88	5.23	.275
20.00	5.37	69	.54	4.72	.236	74	.81	5.06	.253
21.00	5.50	72	.76	5.00	.238
22.00	5.63	70	.71	4.89	.222
23.00	5.75	69	.66	4.74	.206
24.00	5.88	67	.62	4.66	.194
25.00	6.00	66	.58	4.53	.181

NOTE—The above table is based on ordinary twist, 1.20 x square root of hank, with an allowance of 15 minutes per set for doffing and stops.

{118}

FLOOR PLANS OF SPEEDERS.

SLUBBING FRAME R.H.
 INTER, FRAME R.H.
 ROVING FRAME R.H.

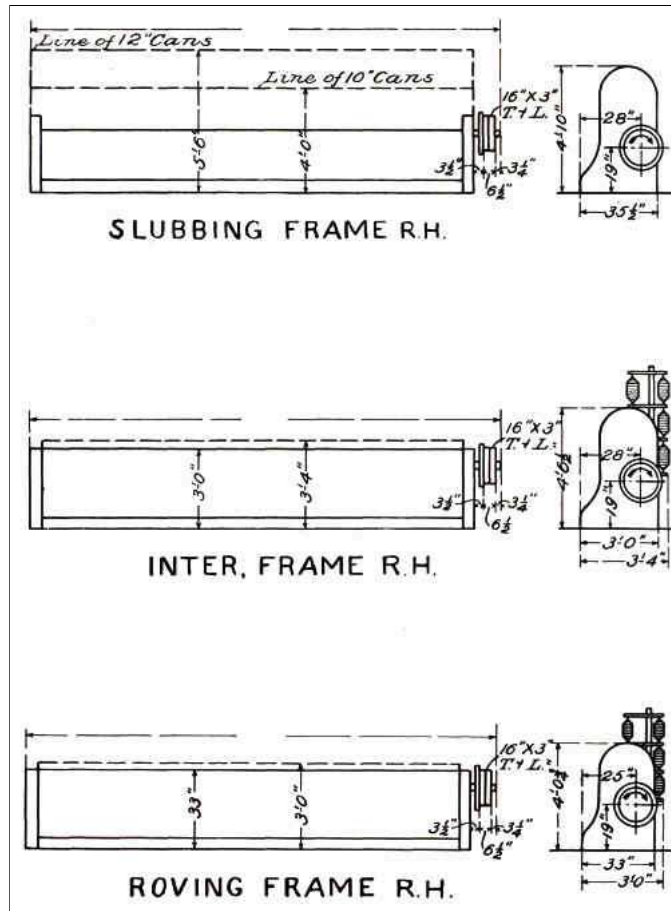

NOTE—The HAND of a speeder is determined by the end on which the driving pulley is located when facing the spindles.

{119}

LENGTHS OVER ALL OF SLUBBING FRAMES.

Space	8 In.	8 $\frac{3}{4}$ In.	9 $\frac{3}{4}$ In.	10 $\frac{3}{4}$ In.
Gauge	4 Spindles in 16 In.	4 Spindles in 17 $\frac{1}{2}$ In.	4 Spindles in 19 $\frac{1}{2}$ In.	4 Spindles in 21 $\frac{1}{2}$ In.
Size of Bobbin	10 x 5 $\frac{1}{4}$ In.	11 x 5 $\frac{1}{2}$ In.	12 x 6 In.	12 x 6 In.
No. of Spindles	Ft. In.	Ft. In.	Ft. In.	Ft. In.
40	16-4	17- 7	19- 3	20-11
42	17-0	18- 3 $\frac{3}{4}$	20- 0 $\frac{3}{4}$	21- 9 $\frac{3}{4}$
44	17-8	19- 0 $\frac{1}{2}$	20-10 $\frac{1}{2}$	22- 8 $\frac{1}{2}$
46	18-4	19- 9 $\frac{1}{4}$	21- 8 $\frac{1}{4}$	23- 7 $\frac{1}{4}$
48	19-0	20- 6	22- 6	24- 6
50	19-8	21- 2 $\frac{3}{4}$	23- 3 $\frac{3}{4}$	25- 4 $\frac{3}{4}$
52	20-4	21-11 $\frac{1}{2}$	24- 1 $\frac{1}{2}$	26- 3 $\frac{1}{2}$
54	21-0	22- 8 $\frac{1}{4}$	24-11 $\frac{1}{4}$	27- 2 $\frac{1}{4}$
56	21-8	23- 5	25- 9	28- 1
58	22-4	24- 1 $\frac{3}{4}$	26- 6 $\frac{3}{4}$	28-11 $\frac{3}{4}$
60	23-0	24-10 $\frac{1}{2}$	27- 4 $\frac{1}{2}$	29-10 $\frac{1}{2}$
62	23-8	25- 7 $\frac{1}{4}$	28- 2 $\frac{1}{4}$	30- 9 $\frac{1}{4}$
64	24-4	26- 4	29- 0	31- 8
66	25-0	27- 0 $\frac{3}{4}$	29- 9 $\frac{3}{4}$	32- 6 $\frac{3}{4}$
68	25-8	27- 9 $\frac{1}{2}$	30- 7 $\frac{1}{2}$	33- 5 $\frac{1}{2}$
70	26-4	28- 6 $\frac{1}{4}$	31- 5 $\frac{1}{4}$	34- 4 $\frac{1}{4}$
72	27-0	29- 3	32- 3	35- 3
74	27-8	29-11 $\frac{3}{4}$	33- 0 $\frac{3}{4}$	36- 1 $\frac{3}{4}$
76	28-4	30- 8 $\frac{1}{2}$	33-10 $\frac{1}{2}$	37- 1 $\frac{1}{2}$
78	29-0	31- 5 $\frac{1}{4}$	34- 8 $\frac{1}{4}$	37-11 $\frac{1}{4}$
80	29-8	32- 2	35- 6	38-10
82	30-4	32-10 $\frac{3}{4}$	36- 3 $\frac{3}{4}$	39- 8 $\frac{3}{4}$
84	31-0	33- 7 $\frac{1}{2}$	37- 1 $\frac{1}{2}$	40- 7 $\frac{1}{2}$
86	31-8	34- 4 $\frac{1}{4}$	37-11 $\frac{1}{4}$	41- 6 $\frac{1}{4}$
88	32-4	35- 1	38- 9	42- 5
90	33-0	35- 9 $\frac{3}{4}$	39- 6 $\frac{3}{4}$	43- 3 $\frac{3}{4}$
92	33-8	36- 6 $\frac{1}{2}$	40- 4 $\frac{1}{2}$	44- 2 $\frac{1}{2}$
94	34-4	37- 3 $\frac{1}{4}$	41- 2 $\frac{1}{4}$	45- 1 $\frac{1}{4}$
96	35-0	38- 0	42- 0	46- 0
98	35-8	38- 8 $\frac{3}{4}$	42- 9 $\frac{3}{4}$	46-10 $\frac{3}{4}$
100	36-4	39- 5 $\frac{1}{2}$	43- 7 $\frac{1}{2}$	47- 9 $\frac{1}{2}$

NOTE—If the projection of fender bracket be taken into account, add 2 inches to the above lengths.

{120}

LENGTHS OVER ALL OF INTERMEDIATE FRAMES.

Space	6 In.	6½ In.	7 In.
Gauge	6 Spindles in 18 In.	6 Spindles in 19½ In.	6 Spindles in 21 In.
Size of Bobbin	9 x 4 ¹/₈ In.	9 x 4 ⁵/₈ In.	10 x 5 In.
No. of Spindles	Ft. In.	Ft. In.	Ft. In.
72	21-0	22-6	24-0
74	21-6	23-0½	24-7
76	22-0	23-7	25-2
78	22-6	24-1½	25-9
80	23-0	24-8	26-4
82	23-6	25-2½	26-11
84	24-0	25-9	27-6
86	24-6	26-3½	28-1
88	25-0	26-10	28-8
90	25-6	27-4½	29-3
92	26-0	27-11	29-10
94	26-6	28-5½	30-5
96	27-0	29-0	31-0
98	27-6	29-6½	31-7
100	28-0	30-1	32-2
102	28-6	30-7½	32-9
104	29-0	31-2	33-4
106	29-6	31-8½	33-11
108	30-0	32-3	34-6
110	30-6	32-9½	35-1
112	31-0	33-4	35-8
114	31-6	33-10½	36-3
116	32-0	34-5	36-10
118	32-6	34-11½	37-5
120	33-0	35-6	38-0
122	33-6	35-0½	38-7
124	34-0	36-7	39-2
126	34-6	37-1½	39-9
128	35-0	37-8	40-4
130	35-6	38-2½	40-11
132	36-0	38-9	41-6
134	36-6	39-3½	42-1
136	37-0	39-10	42-8
138	37-6	40-4½	43-3

NOTE—If the projection of fender bracket be taken into account add 2 inches to the above lengths.

{121}

LENGTHS OVER ALL OF ROVING FRAMES.

Space	5 In.	5 ¹ / ₈ In.	5 ¹ / ₄ In.	5 ¹ / ₂ In.
Gauge	8 Spindles in 20 In.	8 Spindles in 20 ¹ / ₂ In.	8 Spindles in 21 In.	8 Spindles in 22 In.
Size of Bobbin	7x3 ¹/₄ In.	7x3 ¹/₂ In.	8x3 ⁵/₈ In.	8x4 In.
No. of Spindles	Ft. In.	Ft. In.	Ft. In.	Ft. In.
100	23-10	24-4 ¹ / ₄	24-10 ¹ / ₂	25-11
102	24-3	24-9 ¹ / ₈	25-3 ¹ / ₄	26-4 ¹ / ₂
104	24-8	25-2 ¹ / ₂	25-9	26-10
106	25-1	25-7 ¹ / ₈	26-2 ¹ / ₄	27-3 ¹ / ₂
108	25-6	26-0 ¹ / ₄	26-7 ¹ / ₂	27-9
110	25-11	26-5 ¹ / ₈	27-0 ¹ / ₄	28-2 ¹ / ₂
112	26-4	26-11	27-6	28-8
114	26-9	27-4 ¹ / ₂	27-11 ¹ / ₂	29-1 ¹ / ₂
116	27-2	27-9 ¹ / ₄	28-4 ¹ / ₂	29-7
118	27-7	28-2 ¹ / ₂	28-9 ¹ / ₄	30-0 ¹ / ₂
120	28-0	28-7 ¹ / ₂	29-3	30-6
122	28-5	29-0 ¹ / ₂	29-8 ¹ / ₄	30-11 ¹ / ₂
124	28-10	29-5 ¹ / ₄	30-1 ¹ / ₂	31-5
126	29-3	29-10 ¹ / ₂	30-6 ¹ / ₄	31-10 ¹ / ₂
128	29-8	30-4	31-0	32-4
130	30-1	30-9 ¹ / ₈	31-5 ¹ / ₄	32-9 ¹ / ₂
132	30-6	31-2 ¹ / ₄	31-10 ¹ / ₂	33-3
134	30-11	31-7 ¹ / ₈	32-3 ¹ / ₄	33-8 ¹ / ₂
136	31-4	32-0	32-9	34-2
138	31-9	32-5 ¹ / ₂	33-2 ¹ / ₄	34-7 ¹ / ₂
140	32-2	32-10 ¹ / ₄	33-7 ¹ / ₂	35-1
142	32-7	33-3 ¹ / ₈	34-0 ¹ / ₄	35-6 ¹ / ₂
144	33-0	33-9	34-6	36-0
146	33-5	34-2 ¹ / ₈	34-11 ¹ / ₂	36-5 ¹ / ₂
148	33-10	34-7 ¹ / ₄	35-4 ¹ / ₂	37-11
150	34-3	35-0 ¹ / ₂	35-9 ¹ / ₄	37-4 ¹ / ₂
152	34-8	35-5 ¹ / ₂	36-3	37-10
154	35-1	35-10 ¹ / ₂	36-8 ¹ / ₂	38-3 ¹ / ₂
156	35-6	36-3 ¹ / ₈	37-1 ¹ / ₂	38-9
158	35-11	36-8 ¹ / ₂	37-6 ¹ / ₄	39-2 ¹ / ₂
160	36-4	37-2	38-0	39-8
162	36-9	37-7 ¹ / ₂	38-5 ¹ / ₂	40-1 ¹ / ₂
164	37-2	38-0 ¹ / ₄	38-10 ¹ / ₂	40-7
166	37-7	38-5 ¹ / ₂	39-3 ¹ / ₄	41-0 ¹ / ₂
168	38-0	38-10 ¹ / ₂	39-9	41-6
170	38-5	39-3 ¹ / ₂	40-2 ¹ / ₄	41-11 ¹ / ₂
172	38-10	39-8 ¹ / ₄	40-7 ¹ / ₂	42-5
174	39-3	40-1 ¹ / ₂	41-0 ¹ / ₄	42-10 ¹ / ₂
176	39-8	40-7	41-6	43-4
178	40-1	41-0 ¹ / ₄	41-11 ¹ / ₄	43-9 ¹ / ₂
180	40-6	41-5 ¹ / ₄	42-4 ¹ / ₂	44-3
182	40-11	41-10 ¹ / ₂	42-9 ¹ / ₄	44-8 ¹ / ₂
184	41-4	42-3 ¹ / ₂	43-3	45-2
186	41-9	42-8 ¹ / ₂	43-8 ¹ / ₄	45-7 ¹ / ₂

NOTE—If the projection of fender bracket be taken into account, add 2 inches to the above lengths.

If double boss rolls, the number of spindles must divide by four.

{122}

LENGTHS OVER ALL OF JACK FRAMES.

Space	4 In.	4 1/4 In.	4 1/2 In.	4 3/4 In.
Gauge	8 Spindles in 16 In.	8 Spindles in 17 In.	8 Spindles in 18 In.	8 Spindles in 19 In.
Size of Bobbin	6 x 2 1/2 In.	6 x 2 3/4 In.	6 x 3 In.	6 x 3 1/4 In.
No. of Spindles	Ft. In.	Ft. In.	Ft. In.	Ft. In.
140	26-4	27-9 1/2	29-3	30-8 1/2
142	26-8	28-1 3/4	29-7 1/2	31-1 1/4
144	27-0	28-6	30-0	31-6
146	27-4	28-10 1/2	30-4 1/2	31-10 1/2
148	27-8	29-2 1/2	30-9	32-3 1/2
150	28-0	29-6 1/4	31-1 1/2	32-8 1/4
152	28-4	29-11	31-6	33-1
154	28-8	30-3 1/4	31-10 1/2	33-5 1/4
156	29-0	30-7 1/2	32-3	33-10 1/2
158	29-4	30-11 1/4	32-7 1/2	34-3 1/4
160	29-8	31-4	33-0	34-8
162	30-0	31-8 1/4	33-4 1/2	35-0 3/4
164	30-4	32-0 1/2	33-9	35-5 1/2
166	30-8	32-4 3/4	34-1 1/2	35-10 1/4
168	31-0	32-9	34-6	36-3
170	31-4	33-1 1/4	34-10 1/2	36-7 3/4
172	31-8	33-5 1/2	35-3	37-0 1/2
174	32-0	33-9 3/4	35-7 1/2	37-5 1/4
176	32-4	34-2	36-0	37-10
178	32-8	34-6 1/4	36-4 1/2	38-2 3/4
180	33-0	34-10 1/2	36-9	38-7 1/2
182	33-4	35-2 3/4	37-1 1/2	39-0 3/4
184	33-8	35-7	37-6	39-5
186	34-0	35-11 1/4	37-10 1/2	39-9 3/4
188	34-4	36-3 1/2	38-3	40-2 1/2
190	34-8	36-7 3/4	38-7 1/2	40-7 1/4
192	35-0	37-0	39-0	41-0
194	35-4	37-4 1/2	39-4 1/2	41-4 3/4
196	35-8	37-8 1/2	39-9	41-9 1/2
198	36-0	38-0 1/4	40-1 1/2	42-2 1/4
200	36-4	38-5	40-6	42-7
202	36-8	38-9 1/4	40-10 1/2	42-11 1/4
204	37-0	39-1 1/2	41-3	43-4 1/2
206	37-4	39-5 3/4	41-7 1/2	43-9 1/4
208	37-8	39-10	42-0	44-2
210	38-0	40-2 1/4	42-4 1/2	44-6 3/4
212	38-4	40-6 1/2	42-9	44-11 1/2
214	38-8	40-10 3/4	43-1 1/2	45-4 1/4
216	39-0	41-3	43-6	45-9
218	39-4	41-7 1/2	43-10 1/2	46-1 3/4
220	39-8	41-11 1/2	44-3	46-6 1/2
222	40-0	42-3 1/4	44-7 1/2	46-11 1/4
224	40-4	42-8	45-0	47-4
226	40-8	43-0 1/4	45-4 1/2	47-8 1/2
228	41-0	43-4 1/2	45-9	48-1 1/2

NOTE—If the projection of fender bracket be taken into account, add 2 inches to the above lengths.

If double boss rolls, the number of spindles must divide by four.

{123}

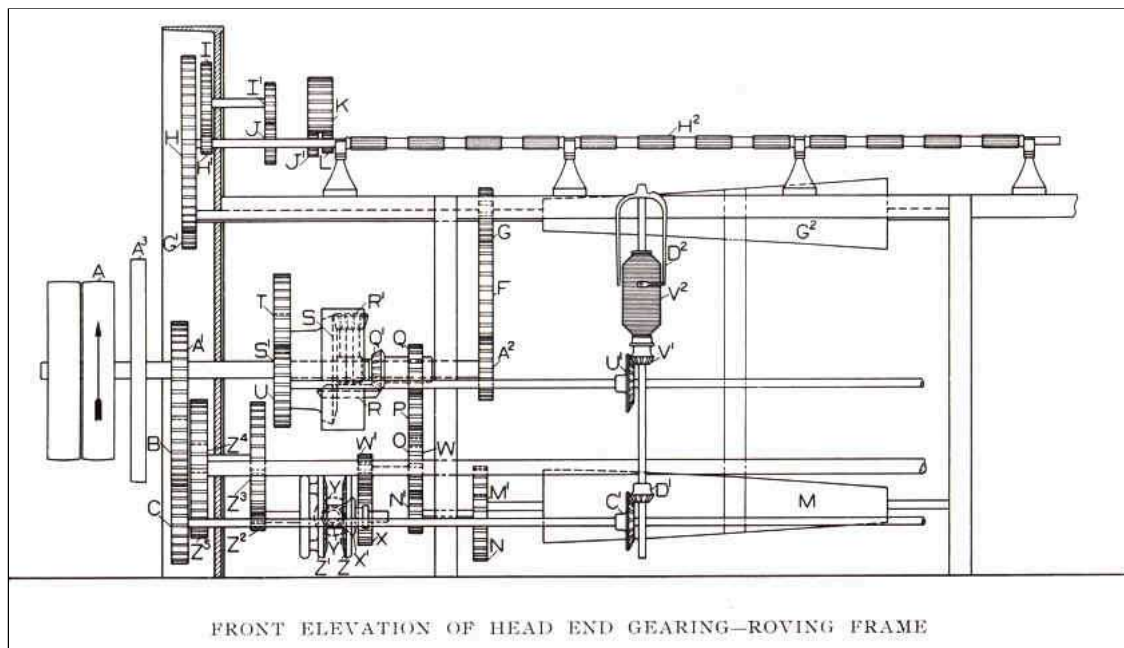

FRONT ELEVATION OF HEAD END GEARING—ROVING FRAME

{124}

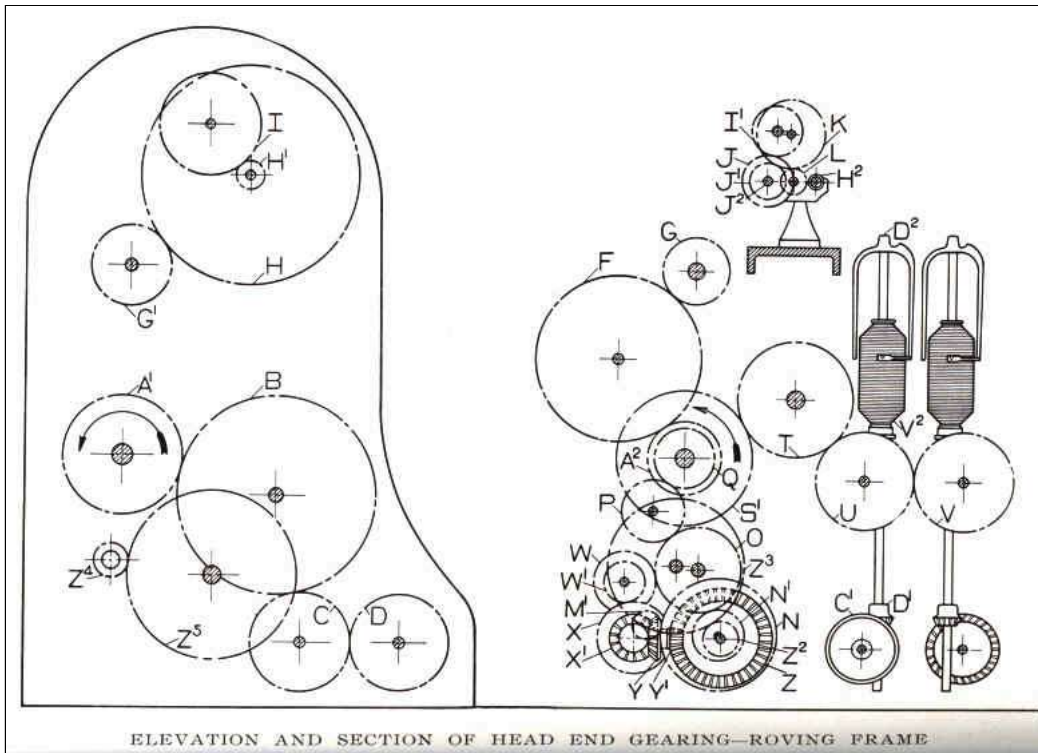

ELEVATION AND SECTION OF HEAD END GEARING—ROVING FRAME

ELEVATION AND SECTION OF HEAD END GEARING—ROVING FRAME

{125}

ROVING FRAMES.

ALPHABETICAL REFERENCES TO DRAWINGS

	Slub. and Inter.	Roving and Jack
A Driving Pulley, 16 in. dia. x 3 in. face
A ¹ Spindle Shaft Driving Gear	40 T.	40 T.
A ² Twist Gear, 20 to 70 T.
A ³ Balance Wheel
B Spindle Shaft Intermediate Gear	75 T.	70 T.
C End Back Spindle Shaft Gear	42 T.	37 T.
C ¹ Spindle Shaft Skew Bevel Gear	55 T.	55 T.
D End Front Spindle Shaft Gear	42 T.	37 T.
D ¹ Spindle Bevel Gear	30 T.	22 T.
D ² Flyer
F Back Intermediate Gear, 128, 120, 112, 104, 96, 88, 80 and 72 T.
G Middle Top Cone Shaft Gear, 32, 40, 48 and 56 T.
G ¹ End Top Cone Shaft Gear	48 T.	44 T.
G ² Top Cone, driving Bottom Cone
H Large Front Roll Gear	130 T.	130 T.
H ¹ Small Front Roll Gear	20 T.	18 and 20 T.
H ² Front Roll, usually	1½ in. dia.	1½ in. dia.
I Crown Gear	80 T.	82 and 120 T.
I ¹ Draft Gear, 30 to 67 T.
J Back Roll Gear	52 T.	52 and 60 T.
J ¹ Middle Roll Driving Gear	30 T.	27 T.
J ² Back Roll, usually	1½ in. dia.	1½ in. dia.
K Broad Top Intermediate Gear	70 T.	70 T.
L Middle Roll Gear	20 T.	20 T.
M Bottom Cone
M ¹ Bottom Cone Shaft Gear, 14 to 36 T.: 16, 17 and 18 T. regular

{126}

ROVING FRAMES-CONTINUED.**ALPHABETICAL REFERENCES TO DRAWINGS.**

	Slub. and Inter.	Roving and Jack
N Fender Gear	68 T.	68 T.
N ¹ Fender Shaft Gear	44 T.	30 T.
O Fender Intermediate Gear	56 T.	56 T.
P Differential Motion Intermediate Gear	44 T.	36 T.
Q Differential Spur Gear	34 T.	34 T.
Q ¹ Differential Bevel Gear	18 T.	18 T.
R Jack Large Bevel Gear	30 T.	30 T.
R ¹ Jack Small Bevel Gear	16 T.	16 T.
S Bell Gear Bevel Gear	48 T.	48 T.
S ¹ Bell Gear	50 T.	50 T.
T Swing Gear	37 T.	42 T.
U Back Bobbin Shaft Gear	42 T.	37 T.
U ¹ Back Bobbin Shaft Skew Bevel Gear	55 T.	55 T.
V Front Bobbin Shaft Gear	42 T.	37 T.
V ¹ Bobbin Bevel Gear	30 T.	22 T.
V ² Bobbin
W Swivel Bracket Gear	31 T.	31 T.
W ¹ Lay Change Gear, 12 to 30 T.
X Gear on Stud Bevel Gear	44 T.	44 T.
X ¹ Bevel Gear driving Horizontal Bevel Gear	22 T.	22 and 15 T.
Y Horizontal Bevel Gear	22 T.	22 and 30 T.
Y ¹ Bevel Gear, driving Reversing Bevel Gear, 12 to 30 T.	15 T.	15 and 13 T.
Z Reversing Bevel Gear, short hub	70 T.	70 T.
Z ¹ Reversing Bevel Gear, long hub	70 T.	70 T.
Z ² Reversing Shaft Change Gear, 14 to 22 T.
Z ³ Gear, driven by Reversing Shaft Change Gear	68 T.	96, 80 & 68 T.
Z ⁴ Lifting Shaft Driving Gear	13 T.	13 T.
Z ⁵ Lifting Shaft Gear	57 T.	73 T.

{127}

SLUBBING, INTERMEDIATE, ROVING AND JACK FRAMES.

DRAFT CALCULATIONS.

Rules:

$$\frac{J \times I \times \text{dia. of Front Roll}}{H^1 \times \text{dia. of Back Roll}} = \text{Draft Constant.}$$

$$\frac{\text{Draft Constant}}{\text{Draft Change Gear (I}^1)} = \text{Draft.}$$

$$\frac{\text{Draft Constant}}{\text{Draft required}} = \text{Draft Change Gear (I}^1).$$

Examples:

If Front and Back Rolls, $1\frac{1}{8}$ in. dia. Back Roll Gear (J) = 52 T. Crown Gear (I) = 80 T. Small Front Roll Gear (H¹) = 20 T.

$$\frac{52 \times 80 \times 1\frac{1}{8}}{20 \times 1\frac{1}{8}} = 208 = \text{Draft Constant.}$$

If Draft Change Gear (I¹) = 50 T,

$$\frac{208}{50} = 4.16 = \text{Draft.}$$

If Draft required = 4.00,

$$\frac{208}{4.00} = 52 \text{ T} = \text{Draft Change Gear (I}^1).$$

TWIST CALCULATIONS.

Rules:

$$\frac{H \times G \times A^1 \times C^1}{G^1 \times C \times D^1 \times \text{Circum. of Front Roll}} = \text{Twist Constant.}$$

$$\frac{\text{Twist Constant}}{\text{Twist Change Gear (A}^2)} = \text{Twist per Inch.}$$

$$\frac{\text{Twist Constant}}{\text{Twist per Inch required}} = \text{Twist Change Gear (A}^2).$$

Examples:

Take twist combination No. 3 on page 131.

Circum. of $1\frac{1}{4}$ in. Front Roll = 3.9270 in.

$$\frac{130 \times 40 \times 40 \times 55}{48 \times 42 \times 30 \times 3.9270} = 48.17 = \text{Twist Constant.}$$

If Twist Change Gear (A^2) = 45 T,

$$\frac{48.17}{45} = 1.07 = \text{Twist per Inch.}$$

If Twist per Inch required = 1.34,

$$\frac{48.17}{1.34} = 36 \text{ T} = \text{Twist Change Gear } (A^2).$$

LAY CALCULATIONS.

Rules:

$$\frac{Z^2 \times Z^2 \times Z \times Y \times X \times W \times Q^1 \times R^1 \times S^1 \times U^1}{Z^4 \times Z^2 \times Y^1 \times X^1 \times Q \times R \times S \times U \times V^1 \times 6\frac{1}{3}} = \text{Lay Constant.}$$

$$\frac{\text{Lay Constant}}{\text{Lay Change Gear } (W^1)} = \text{Laps per Inch on Bobbin.}$$

$$\frac{\text{Lay Constant}}{\text{Laps per Inch required}} = \text{Lay Change Gear } (W^1).$$

NOTE—The distance traversed by the top rail for one revolution of the Lifting Shaft is $6\frac{1}{3}$ in.

Examples:

Take Lay Combination No. 1 on page 134, and Reversing Shaft Change Gear (Z^2) = 16 T.

$$\frac{57 \times 68 \times 70 \times 22 \times 44 \times 31 \times 18 \times 16 \times 50 \times 55}{13 \times 16 \times 18 \times 22 \times 34 \times 30 \times 48 \times 42 \times 30 \times 6\frac{1}{3}} = 200.4 = \text{Lay Constant.}$$

If Lay Change Gear (W^1) = 24 T,

$$\frac{200.4}{24} = 8.35 = \text{Laps per Inch on Bobbin.}$$

If Laps per Inch required = 9.5,

$$\frac{200.4}{9.5} = 21 \text{ T} = \text{Lay Change Gear } (W^1).$$

The following table may be used in calculating the required Laps per Inch on Bobbin for any given hank roving:

{129}

1 hank or below, $7.5 \times$ square root of hank = Laps per Inch

1 hank to 2 hanks, $8.5 \times$ square root of hank = Laps per Inch

2 hanks to 3 hanks, $9.5 \times$ square root of hank = Laps per Inch

3 hanks to 4 hanks, $10.0 \times$ square root of hank = Laps per Inch

4 hanks and above, $10.5 \times$ square root of hank = Laps per Inch

Good results are obtained by using $9.3 \times$ square root of hank.

TAPER AND TENSION CALCULATIONS.

It is difficult to give hard and fast rules for figuring the Taper and Tension Gears, as the required number of teeth on these gears is affected by the kind of stock, length of staple, amount of twist, temperature and humidity.

PRODUCTION CALCULATIONS.

Rule:

$$\frac{840 \text{ (yds. in 1 hank)} \times 36 \text{ (inches in 1 yd.)} \times \text{Twist per inch} \times \text{hank} \times \text{Minutes required for 1 set.}}{\text{weight of bobbin in lbs.}} = \text{R. P. M. of Spindles}$$

Allowing 15 min. per set for doffing, etc.,

$$\frac{600 \text{ (Min. in 10 hours)}}{\text{Min. per set} + 15 \text{ (for doffing, etc.)}} = \text{Sets in 10 hours.}$$

Sets in 10 hours x weight of bobbin in lbs. = lbs. in 10 hours.

Example:

If 4.00 hank, Twist per Inch 2.40, Spindle Speed 1,150, bobbin 7 x 3½ in., weight of bobbin 10 oz. or $\frac{10}{16}$ lbs.

$$\frac{840 \times 36 \times 2.40 \times 4.00 \times 10}{1,150 \times 16} = 157.8 \text{ min. for 1 set.}$$

$$\frac{600}{157.8 + 15} = 3.47 \text{ sets in 10 hours.}$$

$$3.47 \times \frac{10}{16} = 2.17 \text{ lbs. per spindle in 10 hours.}$$

{130}

SLUBBING, INTERMEDIATE, ROVING AND JACK FRAMES.

DRAFT TABLES.

Front Roll Gear, 20 T. Back Roll Gear, 52 T. Crown Gear, 80 T Draft Constant, 208		Front Roll Gear, 18 T. Back Roll Gear, 52 T. Crown Gear, 82 T. Draft Constant, 236.9		Front Roll Gear, 20 T. Back Roll Gear, 60 T. Crown Gear, 120 T. Draft Constant, 359	
Draft Gear	Draft	Draft Gear	Draft	Draft Gear	Draft
67	3.11	67	3.54	67	5.37
66	3.15	66	3.59	66	5.45
65	3.20	65	3.64	65	5.54
64	3.25	64	3.70	64	5.63
63	3.30	63	3.75	63	5.71
62	3.36	62	3.82	62	5.81
61	3.41	61	3.88	61	5.90
60	3.47	60	3.95	60	6.00
59	3.53	59	4.02	59	6.10
58	3.59	58	4.08	58	6.21
57	3.65	57	4.16	57	6.32
56	3.71	56	4.23	56	6.43
55	3.78	55	4.31	55	6.55
54	3.85	54	4.39	54	6.67
53	3.93	53	4.47	53	6.79
52	4.00	52	4.56	52	6.92
51	4.08	51	4.65	51	7.06
50	4.16	50	4.74	50	7.20
49	4.25	49	4.84	49	7.35
48	4.33	48	4.94	48	7.50
47	4.43	47	5.04	47	7.66
46	4.52	46	5.15	46	7.83
45	4.62	45	5.26	45	8.00
44	4.73	44	5.38		
43	4.84	43	5.51		
42	4.95	42	5.64		
41	5.07	41	5.78		
40	5.20	40	5.92		
39	5.33	39	6.07		
38	5.47	38	6.23		
37	5.62	37	6.40		
36	5.78	36	6.58		
35	5.94	35	6.77		
34	6.12	34	6.97		
33	6.30	33	7.18		
32	6.50	32	7.40		
31	6.71	31	7.64		
30	6.93	30	7.90		

NOTE-The above is for front and back rolls the same dia.

{131}

SLUBBING, INTERMEDIATE, ROVING AND JACK FRAMES.

KEY TO TWIST TABLES.(See [pages 132 and 133](#) for complete Twist Tables.)

Twist Combination . .	No. 1	No. 2	No. 3	No. 4	No. 5	No. 6	No. 7	No. 8	No. 9	No. 10	No. 11	No. 12	No. 13	No. 14
Twist Constant . .	38.53	57.80	48.17	67.43	65.07	81.34	97.60	113.87	147.74	72.30	90.38	108.46	126.53	164.17
Diameter of Front Roll, In. . . .	1¼	1¼	1¼	1¼	1¼	1¼	1¼	1¼	1¼	1⅝	1⅝	1⅝	1⅝	1⅝
G Middle Top Cone Gear	32	48	40	56	32	40	48	56	56	32	40	48	56	56
H Large Front Roll Gear	130	130	130	130	130	130	130	130	138	130	130	130	130	138
G ¹ End Top Cone Gear	48	48	48	48	44	44	44	44	36	44	44	44	44	36
A ¹ Spindle Shaft Driving Gear . .	40	40	40	40	40	40	40	40	40	40	40	40	40	40
C & D End Spindle Shaft Gear . .	42	42	42	42	37	37	37	37	37	37	37	37	37	37
C ¹ Spindle Shaft Skew Bevel Gear	55	55	55	55	55	55	55	55	55	55	55	55	55	55
D ¹ Spindle Bevel Gear	30	30	30	30	22	22	22	22	22	22	22	22	22	22

Combinations Nos. 1, 2, 3 and 4 are for Slubbing and Intermediate Frames with 1-1/4-inch dia. Front Roll.

Combinations Nos. 5, 6, 7, 8 and 9 are for Roving and Jack Frames with 1-1/4-inch dia. Front Roll.

Combinations Nos. 10, 11, 12, 13 and 14 are for Roving and Jack Frames with 1-1/8-inch dia. Front Roll.

{132}

SLUBBING, INTERMEDIATE, ROVING AND JACK FRAMES—TWIST TABLES.(See [page 131](#) for key to these tables.)

Twist Comb.	No. 1	No. 2	No. 3	No. 4	No. 5	No. 6	No. 7	Twist Comb.
Twist Constant	38.53	57.80	48.17	67.43	65.07	81.34	97.60	Twist Constant
Twist Gear	1½-inch Diameter Front Roll Turns of Twist per Inch							Twist Gear
70	.55	.83	.69	.96	.98	1.16	1.39	70
69	.56	.84	.70	.98	.94	1.18	1.41	69
68	.57	.85	.71	.99	.95	1.20	1.44	68
67	.57	.86	.72	1.01	.97	1.21	1.46	67
66	.58	.88	.73	1.02	.98	1.23	1.48	66
65	.59	.89	.74	1.04	1.00	1.25	1.50	65
64	.60	.90	.75	1.05	1.02	1.27	1.52	64
63	.61	.92	.76	1.07	1.03	1.29	1.55	63
62	.62	.93	.78	1.09	1.05	1.31	1.57	62
61	.63	.95	.79	1.10	1.07	1.33	1.60	61
60	.64	.96	.80	1.12	1.09	1.35	1.63	60
59	.65	.98	.82	1.14	1.10	1.38	1.66	59
58	.66	1.00	.83	1.16	1.12	1.40	1.68	58
57	.68	1.01	.84	1.18	1.14	1.43	1.71	57
56	.69	1.03	.86	1.20	1.16	1.45	1.74	56
55	.70	1.05	.88	1.23	1.18	1.48	1.77	55
54	.71	1.07	.89	1.25	1.20	1.51	1.81	54
53	.73	1.09	.91	1.27	1.23	1.54	1.84	53
52	.74	1.11	.93	1.30	1.25	1.57	1.88	52
51	.76	1.13	.94	1.32	1.28	1.60	1.92	51
50	.77	1.16	.96	1.35	1.30	1.63	1.95	50
49	.79	1.18	.98	1.38	1.33	1.66	1.99	49
48	.80	1.20	1.00	1.40	1.35	1.69	2.03	48
47	.82	1.23	1.02	1.43	1.38	1.73	2.08	47
46	.84	1.26	1.05	1.47	1.41	1.77	2.12	46
45	.86	1.28	1.07	1.50	1.45	1.81	2.17	45
44	.88	1.31	1.09	1.53	1.48	1.85	2.22	44
43	.90	1.34	1.12	1.57	1.51	1.89	2.27	43
42	.92	1.38	1.15	1.61	1.55	1.94	2.32	42
41	.94	1.41	1.17	1.65	1.59	1.99	2.38	41
40	.96	1.44	1.20	1.69	1.63	2.04	2.44	40
39	.99	1.48	1.23	1.73	1.67	2.09	2.50	39
38	1.01	1.52	1.27	1.77	1.71	2.14	2.57	38
37	1.04	1.56	1.30	1.82	1.76	2.20	2.64	37
36	1.07	1.61	1.34	1.87	1.81	2.26	2.71	36
35	1.10	1.65	1.38	1.92	1.86	2.32	2.79	35
34	1.13	1.70	1.42	1.98	1.91	2.39	2.87	34
33	1.17	1.75	1.46	2.04	1.97	2.47	2.96	33
32	1.20	1.81	1.50	2.11	2.03	2.55	3.05	32
31	1.24	1.86	1.55	2.17	2.10	2.63	3.15	31
30	1.28	1.93	1.61	2.25	2.17	2.71	3.26	30
29	1.33	1.99	1.66	2.33	2.24	2.81	3.37	29
28	1.38	2.06	1.72	2.41	2.32	2.91	3.49	28
27	1.43	2.14	1.78	2.50	2.41	3.02	3.62	27
26	1.48	2.22	1.85	2.59	2.50	3.13	3.76	26
25	1.54	2.31	1.93	2.70	2.60	3.26	3.91	25
24	1.61	2.41	2.01	2.81	2.71	3.39	4.07	24
23	1.67	2.51	2.09	2.93	2.83	3.54	4.25	23
22	1.75	2.63	2.19	3.06	2.96	3.70	4.44	22
21	1.83	2.75	2.29	3.21	3.10	3.88	4.65	21
20	1.93	2.89	2.41	3.37	3.26	4.07	4.88	20

{133}

SLUBBING, INTERMEDIATE, ROVING AND JACK FRAMES-TWIST TABLES.

(See [page 131](#) for key to these tables.)

Twist Comb.	No. 8	No. 9	No. 10	No. 11	No. 12	No. 13	No. 14	Twist Comb.
Twist Constant	113.87	147.74	72.30	90.38	108.46	126.53	164.17	Twist Constant
Twist Gear	1½" Front Roll Twist per Inch		1½" Front Roll Twist per Inch				Twist Gear	
70	1.63	2.11	1.03	1.29	1.55	1.81	2.34	70
69	1.65	2.14	1.05	1.31	1.57	1.83	2.38	69
68	1.67	2.17	1.06	1.33	1.59	1.86	2.42	68
67	1.70	2.21	1.08	1.35	1.62	1.89	2.45	67
66	1.73	2.24	1.10	1.37	1.64	1.92	2.49	66
65	1.75	2.27	1.11	1.39	1.67	1.95	2.53	65
64	1.78	2.31	1.13	1.41	1.69	1.98	2.57	64
63	1.81	2.35	1.15	1.43	1.72	2.01	2.61	63
62	1.84	2.39	1.17	1.46	1.75	2.04	2.65	62
61	1.87	2.43	1.19	1.48	1.78	2.07	2.69	61
60	1.90	2.47	1.21	1.51	1.81	2.11	2.74	60
59	1.93	2.51	1.23	1.53	1.84	2.14	2.79	59
58	1.96	2.55	1.25	1.56	1.87	2.18	2.83	58
57	2.00	2.59	1.27	1.59	1.90	2.22	2.88	57
56	2.03	2.64	1.29	1.61	1.94	2.26	2.93	56
55	2.07	2.69	1.31	1.64	1.97	2.30	2.99	55
54	2.11	2.74	1.34	1.67	2.01	2.34	3.04	54
53	2.15	2.79	1.36	1.70	2.05	2.39	3.10	53
52	2.19	2.84	1.39	1.74	2.09	2.43	3.16	52
51	2.23	2.90	1.42	1.77	2.13	2.48	3.22	51
50	2.28	2.96	1.45	1.81	2.17	2.53	3.28	50
49	2.33	3.02	1.48	1.84	2.21	2.58	3.35	49
48	2.38	3.08	1.51	1.88	2.26	2.64	3.42	48
47	2.43	3.14	1.54	1.92	2.31	2.69	3.49	47
46	2.48	3.21	1.57	1.96	2.36	2.75	3.57	46
45	2.53	3.29	1.61	2.01	2.41	2.81	3.65	45
44	2.59	3.36	1.64	2.05	2.46	2.87	3.73	44
43	2.65	3.44	1.68	2.10	2.52	2.94	3.82	43
42	2.71	3.52	1.72	2.15	2.58	3.01	3.91	42
41	2.78	3.61	1.76	2.20	2.64	3.09	4.00	41
40	2.85	3.70	1.81	2.26	2.71	3.16	4.10	40
39	2.92	3.79	1.85	2.32	2.78	3.24	4.21	39
38	3.00	3.89	1.90	2.38	2.85	3.33	4.32	38
37	3.08	4.00	1.95	2.44	2.93	3.42	4.44	37
36	3.16	4.11	2.01	2.51	3.01	3.51	4.56	36
35	3.25	4.22	2.07	2.58	3.10	3.61	4.69	35
34	3.35	4.35	2.13	2.66	3.19	3.72	4.83	34
33	3.46	4.48	2.19	2.74	3.29	3.83	4.97	33
32	3.56	4.62	2.26	2.82	3.39	3.95	5.13	32
31	3.68	4.77	2.33	2.91	3.50	4.08	5.29	31
30	3.80	4.92	2.41	3.01	3.61	4.22	5.47	30
29	3.93	5.10	2.49	3.12	3.74	4.36	5.66	29
28	4.07	5.28	2.58	3.23	3.87	4.52	5.86	28
27	4.22	5.48	2.68	3.35	4.02	4.69	6.08	27
26	4.38	5.69	2.78	3.48	4.17	4.87	6.31	26
25	4.56	5.92	2.89	3.62	4.34	5.06	6.57	25
24	4.75	6.16	3.01	3.77	4.52	5.27	6.84	24
23	4.95	6.43	3.14	3.93	4.71	5.50	7.14	23
22	5.18	6.72	3.29	4.11	4.93	5.75	7.46	22
21	5.42	7.05	3.44	4.30	5.16	6.02	7.82	21
20	5.70	7.39	3.61	4.52	5.42	6.33	8.21	20

{134}

**SLUBBING, INTERMEDIATE, ROVING AND JACK FRAMES.
LAY GEARING AND CONSTANTS.**

Lay Combination	No. 1	No. 2	No. 3	No. 4	No. 5	No. 6	No. 7	No. 8	No. 9
* Z ² Lifting Shaft Gear	57	57	57	57	73	73	73	73	73
Z ⁴ Lifting Shaft Driving Gear	13	13	13	13	13	13	13	13	13
* Z ³ Gear, driven by Z ²	68	68	68	80	68	80	80	68	80
* Z ² Reversing Shaft Change Gear									
Z ¹ Reversing Bevel Gears	70	70	70	70	70	70	70	70	70
* Y ¹ Bevel Gear driving Z ¹ and Z ²	18	15	15	15	15	15	13	15	18
* Y Horizontal Bevel Gear	22	22	22	22	22	22	22	30	30
* X ¹ Bevel Gear driving Y	22	22	22	22	22	22	22	15	15
X Spur Gear on Stud with X ¹	44	44	44	44	44	44	44	44	44
* W ¹ Lay Change Gear									
W Swivel Bracket Gear	31	31	31	31	31	31	31	31	31
Q Differential Spur Gear	34	34	34	34	34	34	34	34	34
Q ¹ Differential Bevel Gear	18	18	18	18	18	18	18	18	18
R Jack Large Bevel Gear	30	30	30	30	30	30	30	30	30
R ¹ Jack Small Bevel Gear	16	16	16	16	16	16	16	16	16
S Bell Gear Bevel Gear	48	48	48	48	48	48	48	48	48
S ¹ Bell Gear	50	50	50	50	50	50	50	50	50
* C Bobbin Shaft Gear	42	42	37	37	37	37	37	37	37
U ¹ Bobbin Shaft Skew Bevel Gear	55	55	55	55	55	55	55	55	55
* V ¹ Bobbin Bevel Gear	30	30	22	22	22	22	22	22	22

There are two change gears in the lay combination, the Reversing Shaft Change Gear Z² and the Lay Change Gear W¹. Although we have given the full list of Lay Gearing in the above table, only the gears marked * are variable, the others being the same for all frames. The regular change gear is W¹ and the table on the next page gives lay constants for a range of Reversing Shaft Change Gears Z² from 14 to 22 inclusive. To find the correct lay constant select the proper {135} Lay Gearing Combination from the nine given above, note the number of teeth on the Reversing Shaft Change Gear Z² and take the constant which corresponds in the table below. For example, the lay constant for a frame with gearing like No.4 combination and a 16 T. Reversing Shaft Change Gear is 437.9. This divided by the number of teeth on the Lay Change Gear W¹ will give the laps per inch on the bobbin.

TABLE OF LAY CONSTANTS FOR GEARING COMBINATIONS No.1, No.9 AND REVERSING SHAFT CHANGE GEARS 14 TO 22 T.

Nos.	14	15	16	17	18	19	20	21	22
1	229.0	213.7	200.4	118.6	178.1	168.7	160.3	152.7	145.7
2	274.8	256.5	240.4	225.3	213.7	202.5	192.4	183.2	174.9
3	425.4	397.0	372.2	350.3	330.8	313.4	297.7	283.6	270.7
4	500.4	467.1	437.9	412.1	389.2	368.7	350.3	333.6	318.5
5	544.8	508.4	476.7	448.6	423.7	401.4	381.3	363.2	346.7
6	640.9	598.2	560.8	527.8	498.5	472.2	448.6	427.3	407.8
7	739.5	690.2	647.1	609.0	575.2	544.9	517.6	493.0	470.6
8	1089.5	1016.9	953.3	897.3	847.4	802.8	762.7	726.3	693.3
9	1479.0	1380.4	1294.1	1218.0	1150.3	1089.8	1035.3	986.0	941.2

{136}

ROVING TABLE.

FOR NUMBERING BY THE WEIGHT, IN GRAINS, OF 12 YARDS; AND SHOWING TWIST PER INCH.

(Square Root X 1. 20)

Grains Weight	Hank Roving	Square Root	Twist per Inch	Grains Weight	Hank Roving	Square Root	Twist per Inch
400.00	.25	.500	.60	147.06	.68	.825	.99
384.61	.26	.510	.61	144.93	.69	.831	1.00
370.37	.27	.520	.62	142.86	.70	.837	1.00
357.14	.28	.529	.63	140.85	.71	.843	1.01
344.83	.29	.539	.65	138.89	.72	.849	1.02
333.33	.30	.548	.66	135.99	.73	.854	1.02
322.58	.31	.557	.67	135.14	.74	.860	1.03
312.50	.32	.566	.68	133.33	.75	.866	1.04
303.03	.33	.574	.69	131.58	.76	.872	1.05
294.12	.34	.583	.70	129.87	.77	.874	1.05
285.71	.35	.592	.71	128.21	.78	.883	1.06
277.78	.36	.600	.72	126.58	.79	.889	1.07
270.27	.37	.608	.73	125.00	.80	.894	1.07
263.16	.38	.616	.74	123.46	.81	.900	1.08
256.41	.39	.624	.75	121.95	.82	.906	1.09
250.00	.40	.632	.76	120.48	.83	.911	1.09
243.90	.41	.640	.77	119.05	.84	.917	1.10
238.10	.42	.648	.78	117.65	.85	.922	1.11
232.56	.43	.656	.79	116.28	.86	.927	1.11
227.27	.44	.663	.80	114.94	.87	.933	1.12
222.22	.45	.671	.80	113.64	.88	.938	1.13
217.39	.46	.678	.81	112.36	.89	.943	1.13
212.77	.47	.686	.82	111.11	.90	.949	1.14
208.33	.48	.693	.83	109.89	.91	.954	1.14
204.08	.49	.700	.84	108.70	.92	.959	1.15
200.00	.50	.707	.85	107.53	.93	.964	1.16
196.08	.51	.714	.86	106.38	.94	.970	1.16
192.31	.52	.721	.87	105.26	.95	.975	1.17
188.68	.53	.728	.87	104.17	.96	.980	1.18
185.19	.54	.735	.88	103.09	.97	.985	1.18
181.82	.55	.742	.89	102.04	.98	.990	1.19
178.57	.56	.748	.90	101.01	.99	.995	1.19
175.44	.57	.755	.91	100.00	1.00	1.000	1.20
172.41	.58	.762	.91	98.04	1.02	1.010	1.21
169.49	.59	.768	.92	96.15	1.04	1.020	1.22
166.67	.60	.775	.93	94.34	1.06	1.030	1.24
163.93	.61	.781	.94	92.59	1.08	1.039	1.25
161.29	.62	.787	.94	90.91	1.10	1.049	1.26
158.73	.63	.794	.95	89.29	1.12	1.058	1.27
156.25	.64	.800	.96	87.72	1.14	1.068	1.28
153.85	.65	.806	.97	86.21	1.16	1.077	1.29
151.52	.66	.812	.97	84.75	1.18	1.086	1.30
149.25	.67	.819	.98	83.33	1.20	1.095	1.31

{137}

ROVING TABLE—CONTINUED.

FOR NUMBERING BY THE WEIGHT, IN GRAINS, OF 12 YARDS; AND SHOWING TWIST PER INCH

(Square Root X 1.20)

Grains Weight	Hank Roving	Square Root	Twist per Inch	Grains Weight	Hank Roving	Square Root	Twist per Inch
81.97	1.22	1.105	1.33	48.08	2.08	1.442	1.73
80.05	1.24	1.114	1.34	47.62	2.10	1.449	1.74
79.37	1.26	1.122	1.35	47.17	2.12	1.456	1.75
78.12	1.28	1.131	1.36	46.73	2.14	1.463	1.76
76.92	1.30	1.140	1.37	46.30	2.16	1.470	1.76
75.76	1.32	1.149	1.38	45.87	2.18	1.476	1.77
74.63	1.34	1.158	1.39	45.45	2.20	1.483	1.78
73.53	1.36	1.166	1.40	45.05	2.22	1.490	1.79
72.46	1.38	1.175	1.41	44.64	2.24	1.497	1.80
71.43	1.40	1.183	1.42	44.25	2.26	1.503	1.80
70.42	1.42	1.192	1.43	43.86	2.28	1.510	1.81
69.44	1.44	1.200	1.44	43.48	2.30	1.517	1.82
68.49	1.46	1.208	1.45	43.10	2.32	1.523	1.83
67.57	1.48	1.217	1.46	42.74	2.34	1.530	1.84
66.67	1.50	1.225	1.47	42.37	2.36	1.536	1.84
65.79	1.52	1.233	1.48	42.02	2.38	1.543	1.85
64.94	1.54	1.241	1.49	41.67	2.40	1.549	1.86
64.10	1.56	1.249	1.50	41.32	2.42	1.556	1.87
63.29	1.58	1.257	1.51	40.98	2.44	1.562	1.87
62.50	1.60	1.265	1.52	40.65	2.46	1.568	1.88
61.73	1.62	1.273	1.53	40.32	2.48	1.575	1.89
60.98	1.64	1.281	1.54	40.00	2.50	1.581	1.90
60.24	1.66	1.288	1.55	39.68	2.52	1.587	1.90
59.52	1.68	1.296	1.56	39.37	2.54	1.594	1.91
58.82	1.70	1.304	1.56	39.06	2.56	1.600	1.92
58.14	1.72	1.311	1.57	38.76	2.58	1.606	1.93
57.47	1.74	1.319	1.58	38.46	2.60	1.612	1.93
56.82	1.76	1.327	1.59	38.17	2.62	1.619	1.94
56.18	1.78	1.334	1.60	37.88	2.64	1.625	1.95
55.56	1.80	1.342	1.61	37.59	2.66	1.631	1.96
54.95	1.82	1.349	1.62	37.31	2.68	1.637	1.96
54.35	1.84	1.356	1.63	37.04	2.70	1.643	1.97
53.76	1.86	1.364	1.64	36.76	2.72	1.649	1.98
53.19	1.88	1.371	1.65	36.50	2.74	1.655	1.99
52.63	1.90	1.378	1.65	36.23	2.76	1.661	1.99
52.08	1.92	1.386	1.66	35.97	2.78	1.667	2.00
51.55	1.94	1.393	1.67	35.71	2.80	1.673	2.01
51.02	1.96	1.400	1.68	35.46	2.82	1.679	2.01
50.51	1.98	1.407	1.69	35.21	2.84	1.685	2.02
50.00	2.00	1.414	1.70	34.97	2.86	1.691	2.03
49.50	2.02	1.421	1.71	34.72	2.88	1.697	2.04
49.02	2.04	1.428	1.71	34.48	2.90	1.703	2.04
48.54	2.06	1.435	1.72	34.25	2.92	1.709	2.05

{138}

Grains Weight	Hank Roving	Square Root	Twist per In.	Grains Weight	Hank Roving	Square Root	Twist per In.
34.01	2.94	1.715	2.06	14.29	7.00	2.646	3.17
33.78	2.96	1.721	2.07	14.08	7.10	2.665	3.20
33.56	2.98	1.726	2.07	13.89	7.20	2.683	3.22
33.33	3.00	1.732	2.08	13.70	7.30	2.702	3.24
33.26	3.10	1.761	2.11	13.51	7.40	2.720	3.26
31.25	3.20	1.789	2.15	13.33	7.50	2.739	3.29
30.30	3.30	1.817	2.18	13.16	7.60	2.757	3.31
29.41	3.40	1.844	2.21	12.99	7.70	2.775	3.33
28.57	3.50	1.871	2.24	12.82	7.80	2.793	3.35
27.78	3.60	1.897	2.28	12.66	7.90	2.811	3.37
27.03	3.70	1.924	2.31	12.50	8.00	2.828	3.39
26.32	3.80	1.949	2.34	12.35	8.10	2.846	3.42
25.64	3.90	1.975	2.37	12.20	8.20	2.864	3.44
25.00	4.00	2.000	2.40	12.05	8.30	2.881	3.46
24.39	4.10	2.025	2.43	11.90	8.40	2.898	3.48
23.81	4.20	2.049	2.46	11.76	8.50	2.915	3.50
23.26	4.30	2.074	2.49	11.63	8.60	2.933	3.52
22.73	4.40	2.098	2.52	11.49	8.70	2.950	3.54
22.22	4.50	2.121	2.55	11.36	8.80	2.966	3.56
21.74	4.60	2.145	2.57	11.24	8.90	2.983	3.58
21.28	4.70	2.168	2.60	11.11	9.00	3.000	3.60
20.83	4.80	2.191	2.63	10.99	9.10	3.017	3.62
20.41	4.90	2.214	2.66	10.87	9.20	3.033	3.64
20.00	5.00	2.236	2.68	10.75	9.30	3.050	3.66
19.61	5.10	2.258	2.71	10.64	9.40	3.066	3.68
19.23	5.20	2.280	2.74	10.53	9.50	3.082	3.70
18.87	5.30	2.302	2.76	10.42	9.60	3.098	3.72
18.52	5.40	2.324	2.79	10.31	9.70	3.114	3.74
18.18	5.50	2.345	2.81	10.20	9.80	3.130	3.76
17.86	5.60	2.366	2.84	10.10	9.90	3.146	3.78
17.54	5.70	2.387	2.86	10.00	10.00	3.162	3.79
17.24	5.80	2.408	2.89	9.99	11.00	3.317	3.98
16.95	5.90	2.429	2.91	8.33	12.00	3.464	4.16
16.67	6.00	2.449	2.94	7.69	13.00	3.606	4.33
16.39	6.10	2.470	2.96	7.14	14.00	3.742	4.49
16.13	6.20	2.490	2.99	6.67	15.00	3.873	4.65
15.87	6.30	2.510	3.01	6.25	16.00	4.000	4.80
15.62	6.40	2.530	3.04	5.88	17.00	4.123	4.95
15.38	6.50	2.550	3.06	5.56	18.00	4.243	5.09
15.15	6.60	2.569	3.08	5.26	19.00	4.359	5.23
14.93	6.70	2.588	3.11	5.00	20.00	4.472	5.37
14.71	6.80	2.608	3.13	4.76	21.00	4.582	5.50
14.49	6.90	2.627	3.15	4.57	22.00	4.690	5.63
					23.00	4.796	5.75
					24.00	4.899	5.88
					25.00	5.000	6.00

{139}

{140}

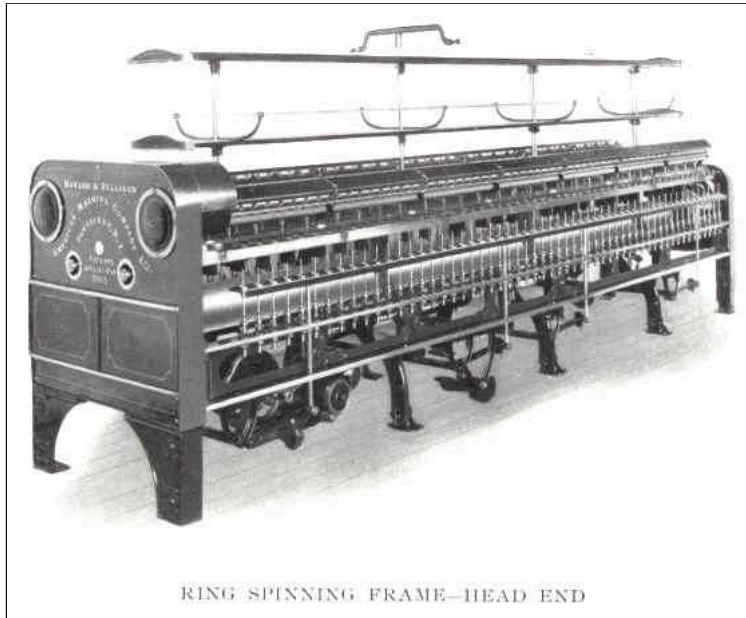

RING SPINNING FRAME—HEAD END

RING SPINNING FRAME—HEAD END

{141}

RING SPINNING FRAMES.

The introduction of these machines was preceded by a careful study of what had already been done in Spinning Frame design.

Our Improved Ring Spinning Frames are made from entirely new patterns, and not only combine the best features previously brought out in such machines, but also many new ideas and improvements which have proved of great benefit to both manufacturers and spinners.

Although these frames were only introduced a few years ago, they are very extensively used, and the demand is steadily increasing. All parts are machined and most of them are made by specially designed tools.

We give below a description of the construction and chief points of advantage of these machines.

LOW FRAMING AND CONSTRUCTION—The Frames are built very low, are extra heavy in all their principal parts, and are designed and constructed so as to stand high speeds without vibration, thus preserving the spindles, ensuring light running and reducing the cost of repairs.

SPINDLE RAILS—These are of the box pattern, specially heavy, and designed to prevent springing, twisting and vibration.

LIFTING RODS—The Lifting Rods, as will be seen in the several illustrations, do not have any foot castings attached to them. They can therefore be easily taken out, cleaned and put back without the necessity of readjustment. These rods are accurately turned and finished by a special process to prevent sticking. The Wave Shaft Arms are designed so that the Ring Rails can be easily leveled by means of adjusting screws.

CREELS—The Creels are constructed with large diameter supporting rods so as to ensure rigidity, reduce vibration and prevent stretching the roving.

{142}

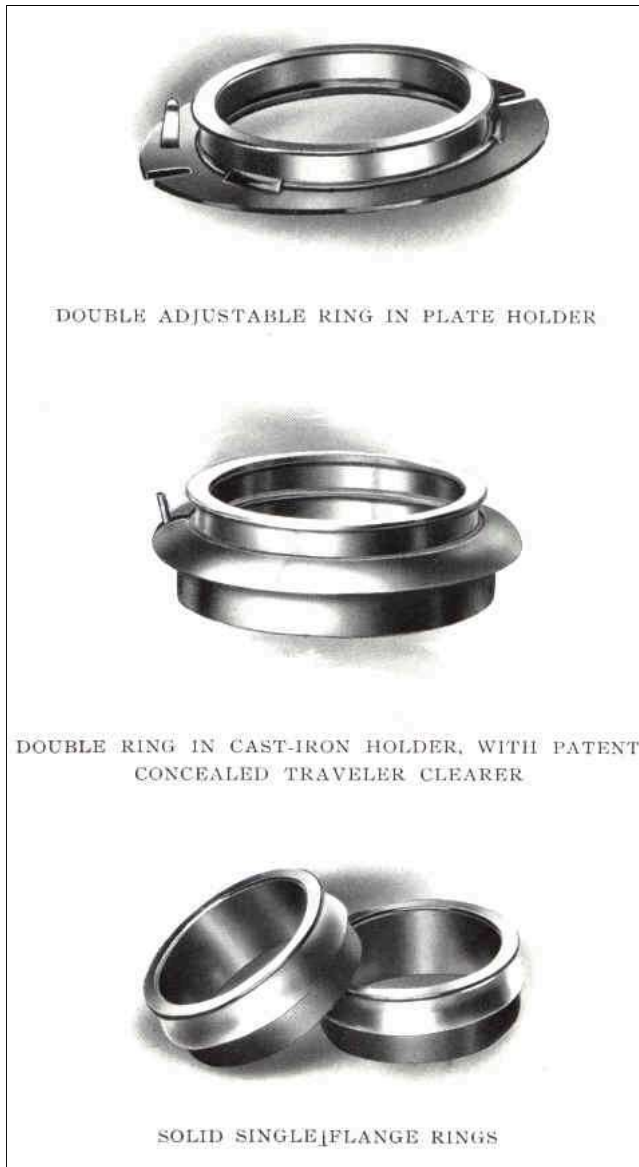

DOUBLE ADJUSTABLE RING IN PLATE HOLDER

DOUBLE RING IN CAST-IRON HOLDER, WITH PATENT
CONCEALED TRAVELER CLEARER

SOLID SINGLE FLANGE RINGS

DOUBLE ADJUSTABLE RING IN PLATE HOLDER

DOUBLE RING IN CAST-IRON HOLDER, WITH PATENT CONCEALED TRAVELER CLEARER

SOLID SINGLE FLANGE RINGS

{143}

FLUTED ROLLS—These steel rolls are carefully and accurately made from superior stock by special machinery. They have large Necks and Squares and are irregularly fluted so as not to cut the Top Rolls.

TOP ROLLS—These have taper ends or pivots, and the Cap Bar Nebs are milled to correspond, thus making it easy to pick the ends and keep them clean.

CAP BARS—These are made with steel fingers which do not break. The upper surface of each finger is flat. The Cap Bar Nebs, which slide on the fingers, are milled and are fastened in position by cap or frog screws so that they cannot twist or get out of place. This arrangement enables the Top Rolls to be accurately set, and makes it much more easy to see the necks of the Bottom Rolls and keep them properly lubricated without removing the Top Rolls or Cap Bars.

RE-LEVELLING—This is now an easy matter and quickly done. Packing up the feet is no longer necessary. The foot of each Spring Piece is provided with a shoe and jack screw, by which it can be raised or lowered to meet any unevenness in the floor.

TRAVERSE RODS AND GUIDES—Iron Traverse Rods are applied, to which are attached adjustable Brass Trumpet Guides.

ADJUSTABLE THREAD BOARDS—Our Thread Boards are adjustable. They can be raised or lowered so as to give, within reasonable limits, any required distance between the Spindle points and Thread Guides.

{144}

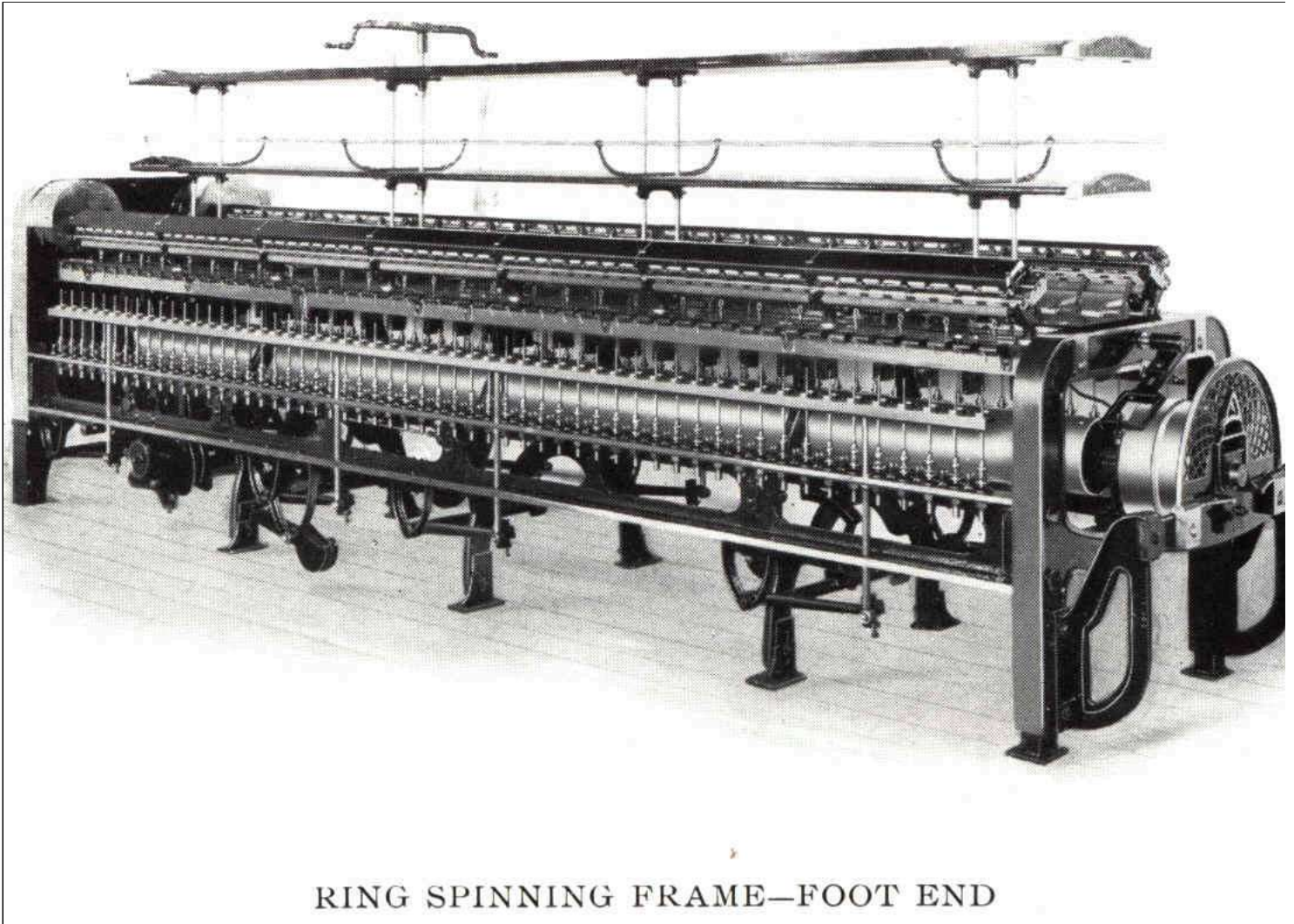

RING SPINNING FRAME—FOOT END

RING SPINNING FRAME-FOOT END

{145}

RINGS—We furnish Single Flange Rings, Double Rings in cast iron Holders, with or without Patent Wire Traveler Clearers, or Double Adjustable Rings in Plate Holders with Traveler Clearers. All Rings are made and finished in the most accurate manner, from a special grade of steel and hardened by improved methods.

SPINDLES—We supply any of the latest improved types of Spindles.

SEPARATORS—We supply the Rhodes-Chandler, Sharples, Doyle or H. & B. (our own). See description, [page 153](#).

SADDLES—The Dixon ordinary, Dixon adjustable or common Saddles are applied as required.

LEVER SCREWS—The Speakman or Common are furnished as specified.

{146}

DRIVING PULLEYS are of our own improved design. The Loose Pulley runs on a cast iron sleeve, which is a part of the ring oiling box. Oil passes through holes in the bottom of this sleeve and lubricates the Loose Pulley. Our method of

supporting the shaft and Loose Pulley together with the perfect lubrication of both prevents the wearing of the shaft, sleeve or Loose Pulley.

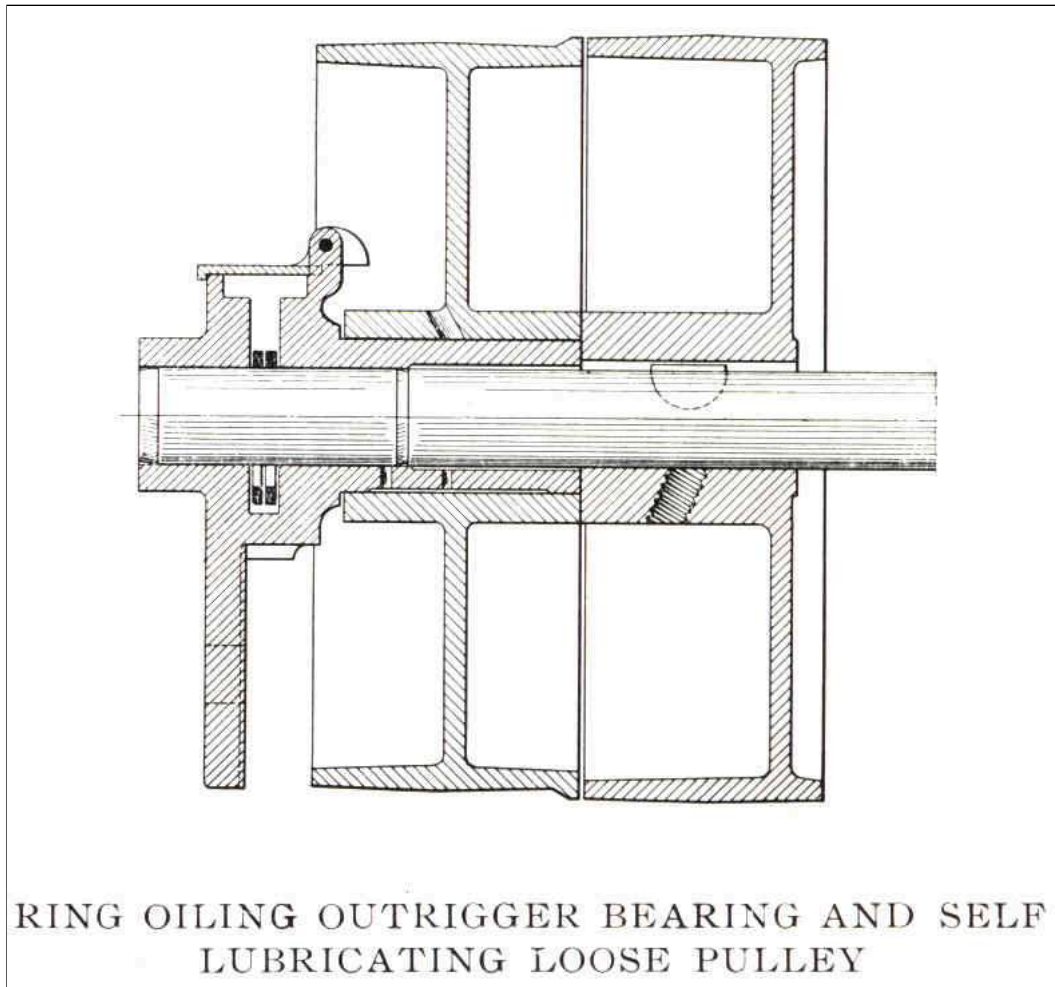

RING OILING OUTRIGGER BEARING AND SELF LUBRICATING LOOSE PULLEY

The Fast Pulley is usually made slightly larger in diameter than the Loose Pulley and is secured to the shaft by a Woodruff key and set screws.

THE OUTRIGGER for supporting the Driving Pulleys can be applied at either the head or foot end, as specified.

{147}

Our improved Cylinder Head is made with a wide surface for the tin and has a long hub split at the end for several inches.

The split portion of the hub is made to grip the shaft by means of a heavy clamp ring and set screw. The shaft cannot be cut by this set screw as it bears on the split hub.

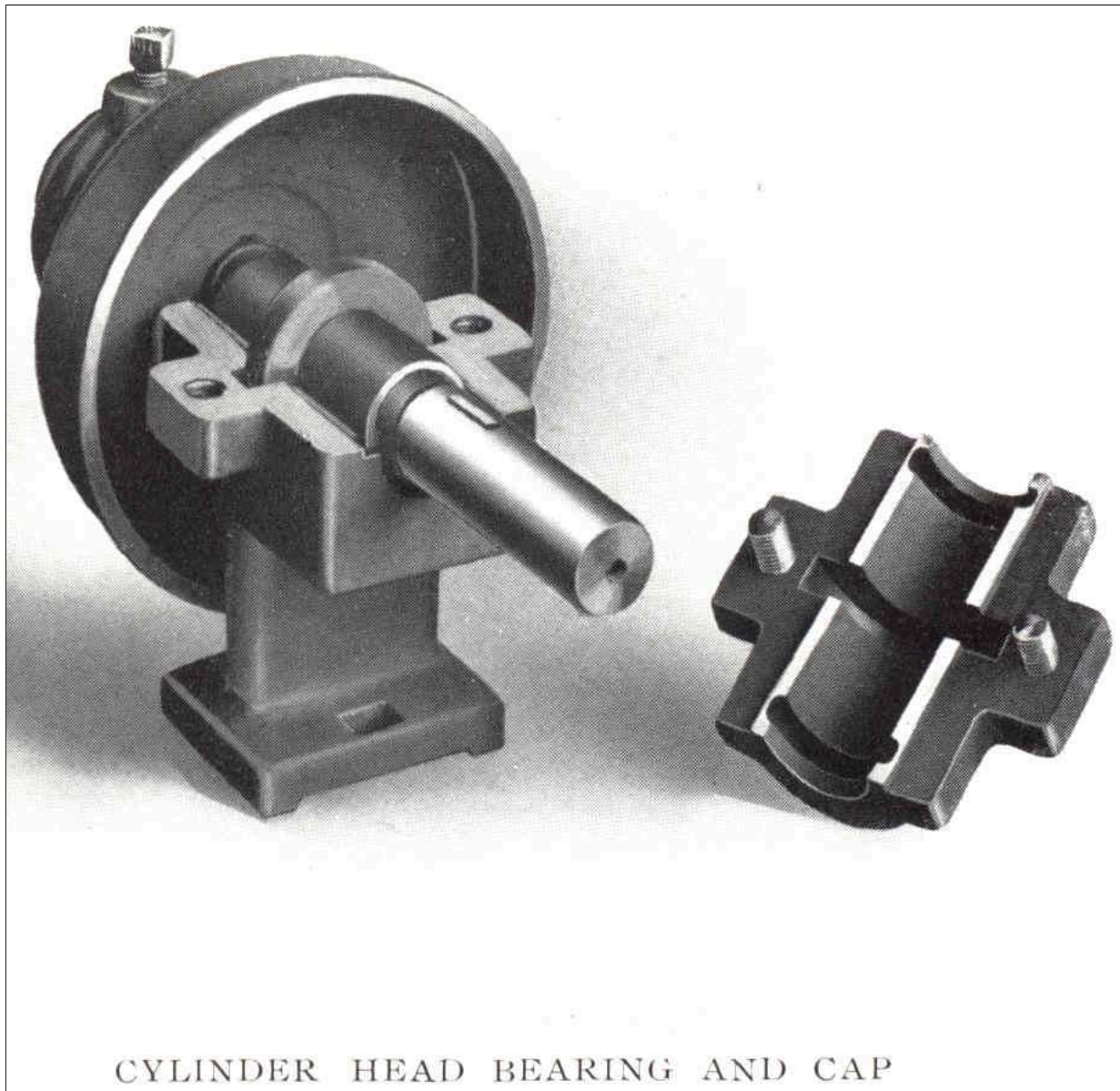

CYLINDER HEAD BEARING AND CAP
CYLINDER HEAD BEARING AND CAP

The shafts are steel, fitted with Woodruff Keys and Phosphor Bronze Bushes with Collars, which make the bearings self-oiling and practically free from wear. Heavy tin is used in the construction of the Cylinders which are carefully balanced and thoroughly tested.

{148}

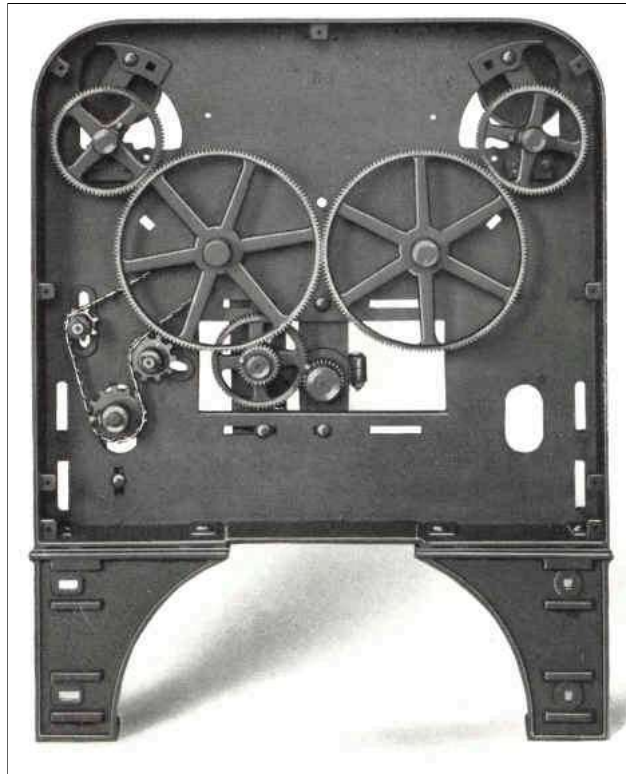

TWIST GEARING

Simplicity and convenience characterize our Ring Spinning Frame gearing. All gears are cut. They are of ample width, run quietly and are well boxed to prevent accidents.

{149}

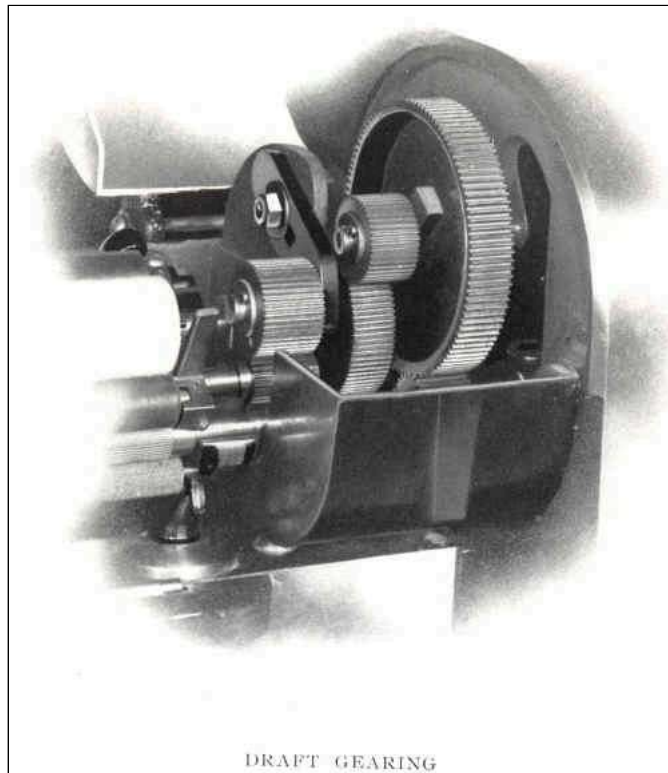
DRAFT GEARING
DRAFT GEARING

The change gears are very conveniently located and a wide range of draft and twist can easily be obtained.

{150}

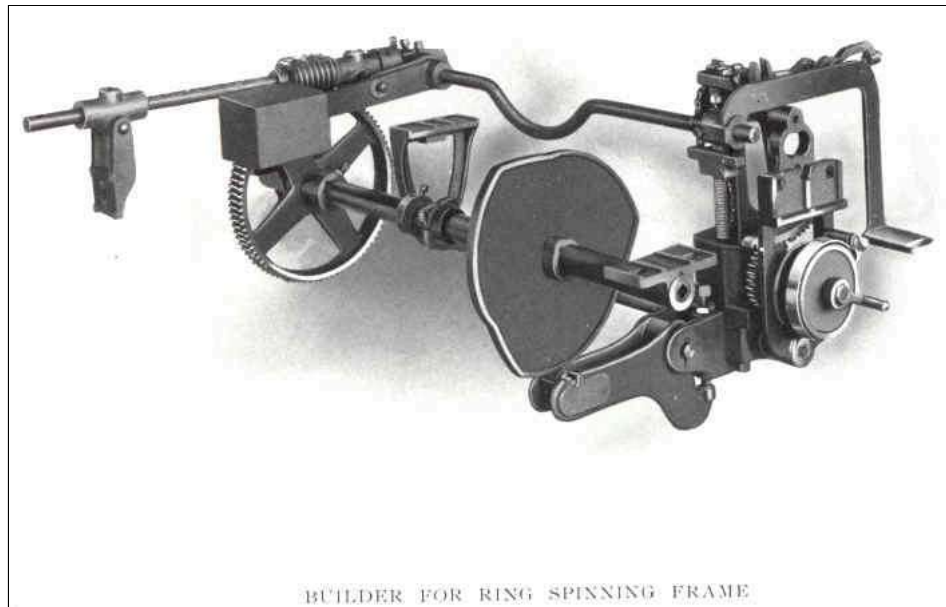

BUILDER FOR RING SPINNING FRAME

{151}

IMPROVED BUILDER.

When designing our improved Spinning Frame Builder, special attention was given to obtaining a wide range in form and build of bobbin combined with simplicity and durability. The changes necessary when altering the wind, pick or traverse have been reduced to a minimum.

The Builder is a combination type, and the change from warp to filling, or vice versa, can be easily and quickly made.

The illustration shows a filling cam only on the cam shaft, but when warp and filling wind are wanted, two cams are placed on this shaft.

The length of the traverse is determined by the adjustable Wave Shaft Stud, which can be easily and quickly raised or lowered, and the Ring Rail can be placed at the correct starting point by means of a thumb nut. The Pick or Take-up Motion is very simple. The pawl is on a plate which has a gear at the back. This gear is driven by a Quadrant which is connected to the top of the Builder. The pawl shield is set so that any required number of teeth can be taken up and no change gears are used.

In the Builder Arm is an adjusting screw, which is used with warp wind to regulate the taper on the bobbin. The taper can be decreased at the bottom and increased at the top by turning in this screw.

When the foot lever is pressed, it throws the Worm out of gear and allows the rail to be dropped. After winding back the Pick Motion, the Frame is ready for doffing and starting a new set.

An eccentric device is applied to enable the "Socket Doff" to be used when desired.

The Worm Gear Shaft is driven by a sprocket chain in the bead end. The speed of this shaft and consequently the speed of the traverse is increased or decreased by changing the Sprocket Gear.

The bevel gears are well protected from dust and fly by a cover, and the Builder screw itself is provided with a cleaner which prevents the collection of dirt in the threads.

{152}

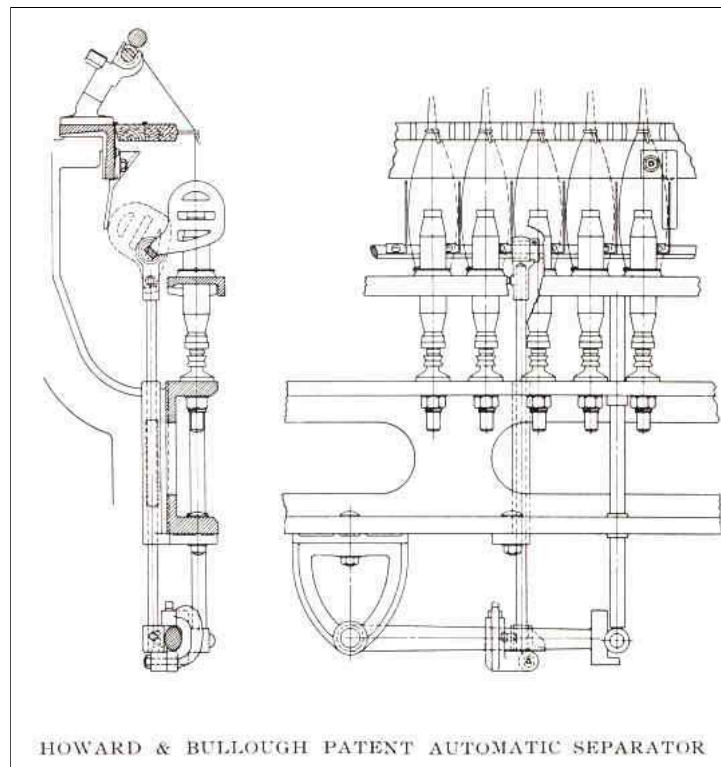

HOWARD & BULLOUGH PATENT AUTOMATIC SEPARATOR

{153}

HOWARD & BULLOUGH PATENT AUTOMATIC SEPARATOR

It has been our aim to combine in this new Separator simplicity and lightness with effectiveness and rigidity. All Separators collect lint, but the Howard & Bullough has so few parts and is so easily cleaned that this disadvantage is reduced to a minimum. The Separator rod holders, which allow the blades to be thrown back out of position for doffing, are neat and strong.

Vibration in a Separator means bad work, and we have given special attention to this point, as evidenced by the double bearings for the lifting rods, the stiffness of the Separator rod carrying the blades, and the general design. In case the operator neglects to return the blades to their working position after doffing, this is taken care of by a curved stop or bracket attached to the roller beam. Easy adjustment for both long and short traverse is a good feature of this Separator.

{154}

FLOOR SPACE OF RING SPINNING FRAMES.

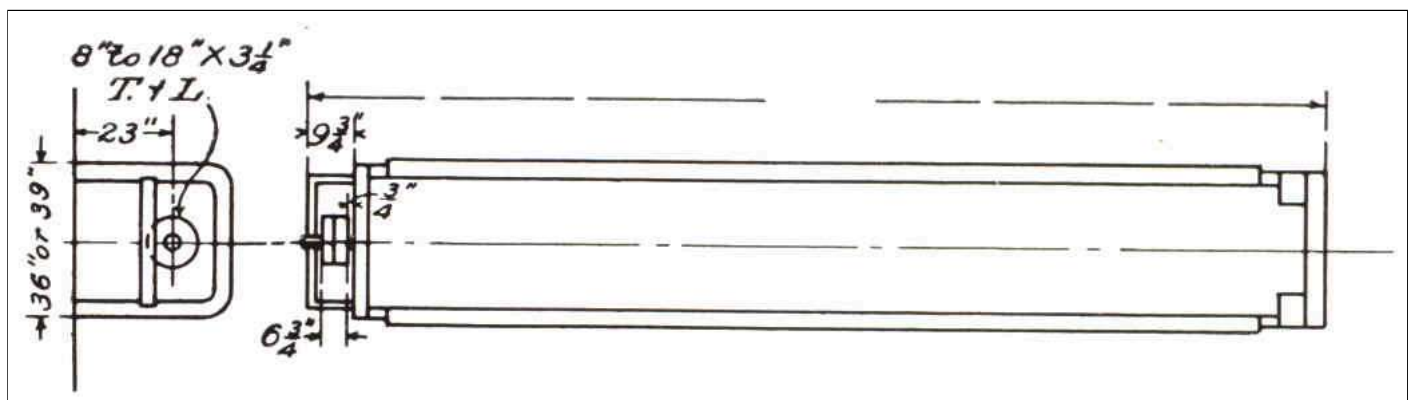

We make 36-in. or 39-in. framing as required. When extra large diameter roving bobbins are used and the creels are required to take double roving, the 39-in. framing is needed to obtain enough space in the creels.

To ascertain the length of Spinning Frames with any number of spindles: Multiply one-half the number of spindles by the gauge and add 2 ft. 1 in. for head and off ends.

Although it is advantageous when possible to keep to the number of spindles given in the table on the opposite page, other lengths can be built, but even boxes are preferable.

DRIVING PULLEYS are 8 in. to 18 in. dia., 3-1/4 in. face.

{155}

LENGTHS OVER ALL OF RING SPINNING FRAMES.

Number of Spindles	Gauge $2\frac{1}{2}$ "	Gauge $2\frac{3}{8}$ "	Gauge $2\frac{3}{4}$ "
160	18'-9"	19'-7"	20'-5"
176	20'-5"	21'-4"	22'-3"
192	22'-1"	23'-1"	24'-1"
208	23'-9"	24'-10"	25'-11"
224	25'-5"	26'-7"	27'-9"
240	27'-1"	28'-4"	29'-7"
256	28'-9"	30'-1"	31'-5"
272	30'-5"	31'-10"	33'-3"
288	32'-1"	33'-7"	35'-1"
304	33'-9"	35'-4"	36'-11"
320	35'-5"	37'-1"	38'-9"
Number of Spindles	Gauge 3 "	Gauge $3\frac{1}{4}$ "	Gauge $3\frac{1}{2}$ "
156	21'-7"	23'-2 $\frac{1}{2}$ "	24'-10"
168	23'-1"	24'-10"	26'-7"
180	24'-7"	26'-5 $\frac{1}{2}$ "	28'-4"
192	26'-1"	28'-1"	30'-1"
204	27'-7"	29'-8 $\frac{1}{2}$ "	31'-10"
216	29'-1"	31'-4"	33'-7"
228	30'-7"	32'-11 $\frac{1}{2}$ "	35'-4"
240	32'-1"	34'-7"	37'-1"
252	33'-7"	36'-2 $\frac{1}{2}$ "	38'-10"
264	35'-1"	37'-10"	40'-7"
276	36'-7"	39'-5 $\frac{1}{2}$ "	42'-4"

{156}

PRODUCTION TABLE OF RING WARP YARN.

FRONT ROLL, 1 IN. DIA.

No. of Yarn	Twist per In.	Revs. Front Roll per Minute	Revs. Spindle per Minute	Hanks per Spindle per day of 10 Hours	Lbs. per Spindle per week of 60 Hours	No. of Yarn
4	9.50	166.0	4950	9.12	13.67	4
5	10.62	163.2	5450	8.96	10.75	5
6	11.63	161.4	5900	8.86	8.86	6
7	12.56	159.6	6300	8.76	7.51	7
8	13.43	157.6	6650	8.65	6.49	8
9	14.25	156.3	7000	8.58	5.72	9
10	15.02	153.6	7250	8.53	5.12	10
11	15.75	151.5	7500	8.41	4.59	11
12	16.45	150.0	7750	8.33	4.16	12
13	17.12	147.8	7950	8.21	3.79	13
14	17.77	145.9	8150	8.10	3.47	14
15	18.39	143.6	8300	7.98	3.19	15
16	19.00	141.5	8450	7.86	2.98	16
17	19.58	139.7	8600	7.76	2.81	17
18	20.15	138.1	8750	7.67	2.57	18
19	20.70	136.0	8850	7.55	2.39	19
20	21.24	134.0	8950	7.53	2.26	20
21	21.76	132.3	9050	7.43	2.12	21
22	22.27	130.0	9100	7.30	1.99	22
23	22.78	127.8	9150	7.18	1.87	23
24	23.27	125.8	9200	7.07	1.76	24
25	23.75	124.6	9300	7.00	1.68	25
26	24.22	123.7	9400	7.02	1.62	26
27	24.68	121.9	9450	6.92	1.54	27
28	25.13	120.2	9500	6.83	1.46	28
29	25.58	118.2	9500	6.71	1.39	29
30	26.02	116.2	9500	6.60	1.32	30
31	26.44	114.4	9500	6.50	1.26	31
32	26.87	112.5	9500	6.39	1.20	32
33	27.28	111.4	9550	6.33	1.15	33
34	27.69	110.3	9600	6.26	1.10	34
35	28.10	108.7	9600	6.24	1.07	35

Allowance has been made for doffing, etc. Standard Warp Twist used, $4.75 \times$ square root of number of yarn.

{157}

PRODUCTION TABLE OF RING WARP YARN.

FRONT ROLL, 1 IN. DIA.

No. of Yarn	Twist per In.	Revs. Front Roll per Minute	Revs. Spindle per Minute	Hanks per Spindle per day of 10 Hours	Lbs. per Spindle per week of 60 Hours	No. of Yarn
36	28.50	108.3	9700	6.22	1.04	36
37	28.89	106.8	9700	6.13	0.99	37
38	29.28	106.5	9800	6.11	0.97	38
39	29.66	105.2	9800	6.04	0.93	39
40	29.07	106.2	9700	6.10	0.91	40
41	29.44	104.9	9700	6.02	0.88	41
42	29.80	103.6	9700	5.95	0.85	42
43	30.13	102.5	9700	5.88	0.82	43
44	30.49	101.2	9700	5.81	0.79	44
45	30.82	100.2	9700	5.82	0.77	45
46	31.18	99.0	9700	5.75	0.75	46
47	31.51	98.0	9700	5.69	0.73	47
48	31.83	97.0	9700	5.63	0.70	48
49	32.20	95.9	9700	5.57	0.68	49
50	32.52	94.9	9700	5.51	0.66	50
55	33.34	91.6	9600	5.37	0.59	55
60	34.83	87.7	9600	5.20	0.52	60
65	36.27	84.2	9600	4.99	0.46	65
70	37.62	81.2	9600	4.81	0.41	70
75	38.10	79.4	9500	4.71	0.38	75
80	39.33	76.9	9500	4.61	0.35	80
85	39.64	74.0	9100	4.43	0.31	85
90	40.76	71.0	9100	4.30	0.29	90
95	41.88	68.5	9000	4.15	0.26	95
100	42.00	65.9	8700	4.03	0.24	100
110	44.01	61.5	8500	3.76	0.20	110
120	44.89	58.1	8200	3.55	0.18	120
130	46.74	53.1	7800	3.28	0.15	130
140	47.32	47.1	7000	2.91	0.13	140
150	48.96	42.9	6600	2.65	0.11	150
160	50.56	37.8	6000	2.34	0.09	160
170	52.12	33.6	5500	2.08	0.07	170

Allowance has been made for doffing, etc. Twist per inch, $4.75 \times$ square root of number up to 40s. For 40s and finer the twist per inch is graduated from 4.60 to $4.00 \times$ square root of number.

{158}

PRODUCTION TABLE OF RING FILLING YARN.

FRONT ROLL, 1 IN. DIA.

No. of Yarn	Twist per In.	Revs. Front Roll per Minute	Revs. Spindle per Minute	Hanks per Spindle per day of 10 Hours	Lbs. per Spindle per week of 60 Hours	No. of Yarn
4	6.50	196	4000	9.66	14.48	4
5	7.27	194	4400	9.48	11.38	5
6	7.96	192	4800	9.57	9.56	6
7	8.60	190	5150	9.49	8.14	7
8	9.19	188	5450	9.41	7.06	8
9	9.75	186	5700	9.27	6.18	9
10	10.28	184	5950	9.28	5.57	10
11	10.78	182	6150	9.15	4.99	11
12	11.26	179	6350	9.15	4.58	12
13	11.72	177	6500	9.01	4.16	13
14	12.16	175	6700	8.93	3.83	14
15	12.59	173	6850	8.83	3.53	15
16	13.00	170	6950	8.68	3.25	16
17	13.40	168	7100	8.60	3.04	17
18	13.79	166	7200	8.47	2.83	18
19	14.17	164	7300	8.37	2.65	19
20	14.53	162	7400	8.35	2.51	20
21	14.89	160	7500	8.26	2.36	21
22	15.24	158	7600	8.18	2.23	22
23	15.59	156	7700	8.10	2.11	23
24	15.92	154	7800	8.03	2.01	24
25	16.25	152	7850	7.93	1.90	25
26	16.57	150	7850	7.86	1.81	26
27	16.89	148	7850	7.95	1.77	27
28	17.20	146	7900	7.85	1.68	28
29	17.50	144	7900	7.72	1.60	29
30	17.80	141	7900	7.77	1.55	30
31	18.10	139	7900	7.67	1.49	31
32	18.38	137	7900	7.66	1.43	32
33	18.67	135	7900	7.57	1.37	33
34	18.95	133	7900	7.54	1.33	34
35	19.23	131	7900	7.50	1.28	35

Allowance has been made for doffing, etc. Filling Twist used, $3.25 \times$ square root of number of yarn.

{159}

PRODUCTION TABLE OF RING FILLING YARN.

FRONT ROLL, 1 IN. DIA.

No. of Yarn	Twist per In.	Revs. Front Roll per Minute	Revs. Spindle per Minute	Hanks per Spindle per day of 10 Hours	Lbs. per Spindle per week of 60 Hours	No. of Yarn
36	19.50	129	7900	7.40	1.24	36
37	19.77	127	7900	7.30	1.17	37
38	20.03	125	7900	7.21	1.14	38
39	20.30	124	7900	7.11	1.09	39
40	20.55	122	7900	7.10	1.06	40
41	20.81	121	7900	7.01	1.03	41
42	21.06	119	7900	6.93	0.99	42
43	21.31	118	7900	6.84	0.95	43
44	21.56	117	7900	6.77	0.92	44
45	21.80	115	7900	6.69	0.89	45
46	22.04	114	7900	6.62	0.86	46
47	22.28	113	7900	6.55	0.83	47
48	22.52	112	7900	6.48	0.81	48
49	22.75	111	7900	6.41	0.79	49
50	22.98	109	7900	6.42	0.77	50
55	24.10	104	7900	6.18	0.67	55
60	25.17	100	7900	5.99	0.60	60
65	26.20	95	7800	5.76	0.53	65
70	27.19	91	7800	5.56	0.47	70
75	28.15	88	7800	5.37	0.43	75
80	29.07	84	7700	5.27	0.40	80
85	29.96	81	7600	5.04	0.35	85
90	30.83	77	7400	4.90	0.32	90
95	31.68	74	7400	4.77	0.30	95
100	32.50	71	7200	4.64	0.28	100
110	34.09	64	6900	4.31	0.23	110
120	35.60	58	6500	3.89	0.19	120
130	37.06	53	6200	3.56	0.16	130
140	38.45	49	5900	3.25	0.14	140
150	39.80	45	5600	3.00	0.12	150
160	41.11	41	5300	2.75	0.10	160
170	42.37	38	5000	2.52	0.09	170

Allowance has been made for doffing, etc. Filling Twist used, $3.25 \times$ square root of number of yarn.

{160}

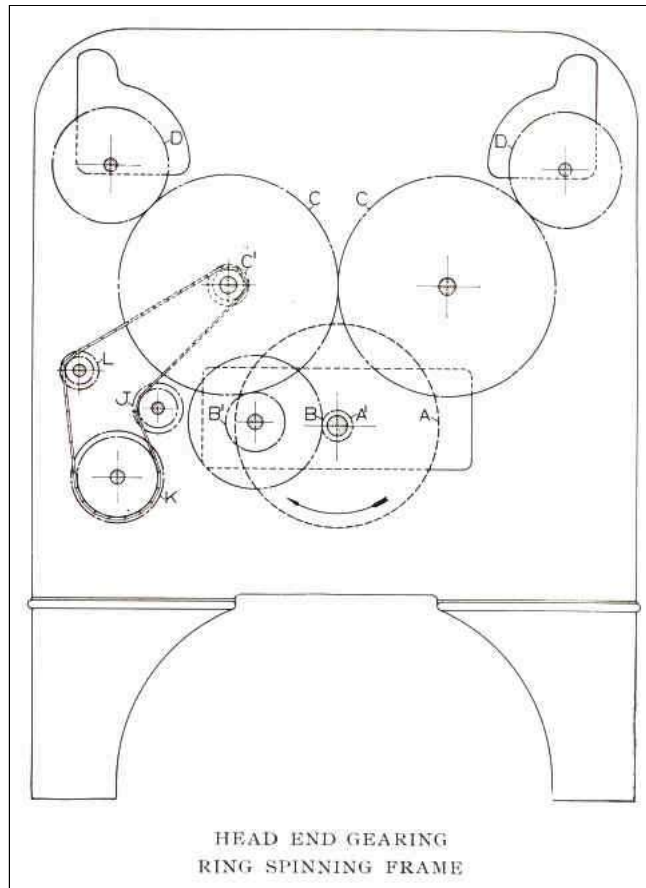

HEAD END GEARING
RING SPINNING FRAME
HEAD END GEARING
RING SPINNING FRAME

{161}

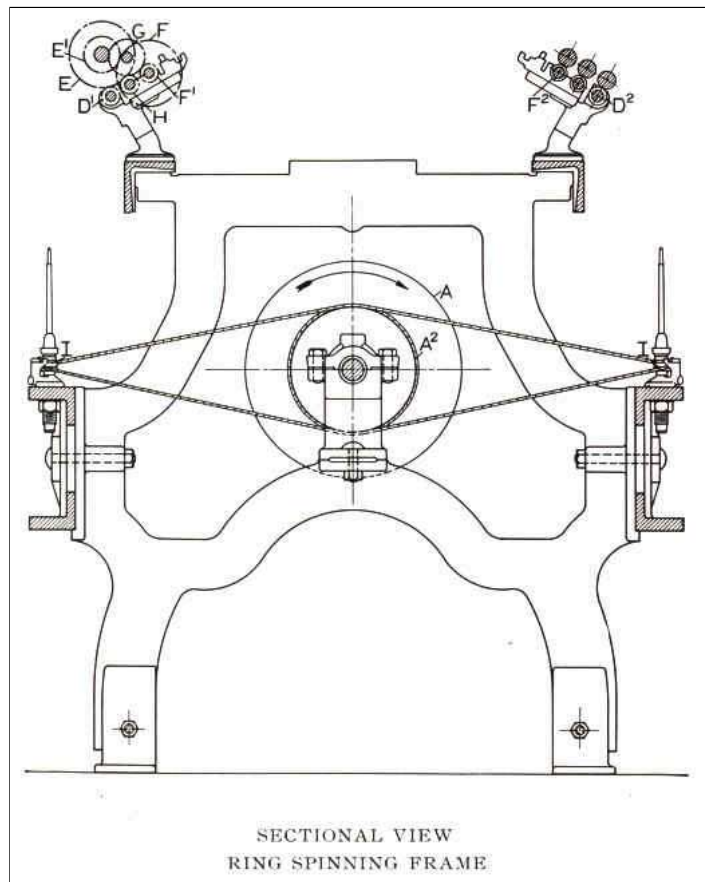

SECTIONAL VIEW
RING SPINNING FRAME
SECTIONAL VIEW

{162}

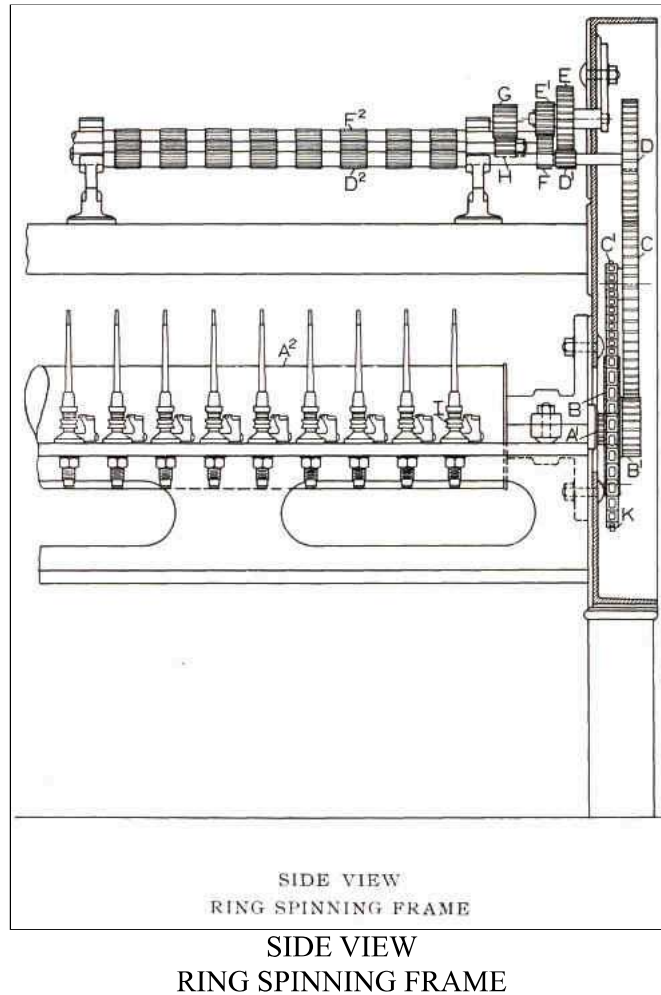

{163}

SPINNING FRAME.

ALPHABETICAL REFERENCES TO DRAWINGS.

A Driving Pulley, 8 in. to 18 in. dia., advancing by 1/2 in. increments; 3-1/4 in. face.

A¹ Cylinder Gear, 17, 21, 29 and 39 T.

A² Cylinder, 7 in. dia.

B Jack Gear, 72, 76, 86, 96 and 106 T.

B¹ Twist Change Gear, 25-67 T., advancing by one tooth.

C Intermediate Gear, 156 T. for 36-in. frame; 171 T. for 39 in. frame.

C¹ Builder Motion Driving Sprocket Gear, 8 T.

D Front Roll Twist Gear, 84 T.

D¹ Front Roll Draft Gear, 21 and 27 T.

D² Front Roll, usually 1 in. dia.; sometimes 1-1/16 in. dia. and 1-7/8 in. dia.

E Crown Gear, 72, 90 and 108 T.

E¹ Draft Change Gear, 32-59 T., advancing by one tooth.

F Large Back Roll Gear, 79 and 89 T.

- F¹ Small Back Roll Gear, 28 T. for 7/8 in. dia. Middle and Back Rolls, 29 T. for 15/16 in. dia. Middle Roll, 1-1/16 in. dia. Back Rolls.
- F² Back Roll, usually 7/8 in. dia., sometimes 11/16 in. dia. and 1-1/8 in. dia.
- G Broad Middle Roll Intermediate Gear, 48 T.
- H Middle Roll Gear, 26 T. for 7/8 in. dia. Middle and Back Rolls, 24 T. for 15/16 in. dia. Middle and 1-1/16 in. dia. Back Rolls.
- I Whorl, 3/4 in., 13/16 in. and 7/8 in. dia.
- J Carrier Sprocket Gear, 10 T.
- K Builder Motion Worm Shaft Sprocket Gear, 12, 14, 16, 18, 20, 22 and 24 T., dependent upon the Number of Yarn.
- L Carrier Sprocket Gear, 7 T.

{164}

SPINNING FRAMES.**DRAFT CALCULATIONS.****TWIST CALCULATIONS.**

Rules:

$$\frac{F \times E \times \text{dia. of Front Roll}}{D^1 \times \text{dia. of Back Roll}} = \text{Draft Constant.}$$

$$\frac{\text{Draft Constant}}{\text{Draft Change Gear (E}^1\text{)}} = \text{Draft.}$$

$$\frac{\text{Draft Constant}}{\text{Draft required}} = \text{Draft Change Gear (E}^1\text{).}$$

Examples:

If Front Roll Gear (D¹) = 27 T, Back Roll Gear (F) = 89 T, Crown Gear (E) = 72 T. Front Roll, 1 inch dia. Back Roll, 7/8 inch dia.

$$\frac{89 \times 72 \times 1}{27 \times \frac{7}{8}} = 271.24 = \text{Draft Constant.}$$

If Draft Change Gear (E¹) = 34 T.

$$\frac{271.24}{34} = 7.98 = \text{Draft.}$$

If Draft required = 6.00

$$\frac{271.24}{6.00} = 45 \text{ T.} = \text{Draft Change Gear (E}^1\text{).}$$

TWIST CALCULATIONS.

Rules:

$$\frac{D \times B \times \text{Ratio of Whirl Speed to Cylinder Speed}}{A^1 \times \text{Circum. of Front Roll}} = \text{Twist Constant.}$$

$$\frac{\text{Twist Constant}}{\text{Twist Change Gear (B}^1\text{)}} = \text{Twist per inch.}$$

$$\frac{\text{Twist Constant}}{\text{Twist per inch required}} = \text{Twist Change Gear (B}^1\text{).}$$

When figuring the Ratio of Whirl Speed to Cylinder Speed we add 1/3 inch to the diameters to allow for the band.

{165}

Examples:

If Cylinder Gear (A¹) = 21 T, Jack Gear (B) = 96 T,
Front Roll Gear (D) = 84 T. Cylinder, 7 inch dia.
Whirl, $\frac{3}{4}$ inch dia. Ratio of Whirl Speed to Cylinder
Speed = 8.143. Front Roll, 1 inch dia.

$$\frac{84 \times 96 \times 8.143}{21 \times 3.1416} = 995.31 = \text{Twist Constant.}$$

If Twist Change Gear (B¹) = 40 T.

$$\frac{995.31}{40} = 24.88 \text{ Turns Twist per inch.}$$

If Twist per inch required = 18.10.

$$\frac{995.31}{18.10} = 55 \text{ T} = \text{Twist Change Gear (B}^1\text{).}$$

PRODUCTION CALCULATIONS.**Rule:**

$$\frac{\text{R. P. M. of Front Roll} \times \text{Circum. of Front Roll} \times 3600 \text{ (min. in 60 hours)}}{36 \text{ (inches in 1 yd.)} \times 840 \text{ (yds. in 1 hank)} \times \text{No. of Yarn}} = \text{Lbs. Production per Spindle in 60 hours.}$$

Example:

If No. 20 Warp Yarn, 134.0 R. P. M. of Front Roll, Circum. of 1 inch Front Roll = 3.1416 inches. 10 per cent. allowance for stops, etc.

$$\frac{134.0 \times 3.1416 \times 3600 \times .90}{36 \times 840 \times 20} = 2.26 \text{ lbs. in 60 hours.}$$

In our production tables on [pages 156 to 159](#), the allowance for doffing, waste, etc., varies with the numbers of yarn, the percentage loss being greater for coarse than fine work.

{166}

RING SPINNING FRAME, DRAFT TABLE.
FRONT ROLL 1 IN. DIAM. BACK ROLL 7/8 IN. DIAM.

Front Roll Gear	27	27	27	21	27	21	21
Back Roll Gear	89	79	89	89	89	89	89
Crown Gear	72	90	90	72	108	90	108
Draft Constant	271.24	300.95	339.05	348.73	406.86	435.92	523.10
Draft Gear	Draft	Draft	Draft	Draft	Draft	Draft	Draft
32	8.48	9.40	10.60	10.89	12.71	13.62	16.35
33	8.22	9.12	10.27	10.57	12.33	13.21	15.85
34	7.98	8.85	9.97	10.26	11.97	12.82	15.39
35	7.75	8.60	9.69	9.96	11.62	12.46	14.95
36	7.42	8.36	9.42	9.69	11.30	12.11	14.53
37	7.33	8.13	9.16	9.43	11.00	11.78	14.14
38	7.14	7.92	8.92	9.18	10.71	11.47	13.77
39	6.95	7.72	8.69	8.94	10.43	11.18	13.41
40	6.78	7.52	8.48	8.72	10.17	10.90	13.08
41	6.62	7.34	8.27	8.51	9.92	10.63	12.76
42	6.46	7.17	8.07	8.30	9.69	10.38	12.46
43	6.31	7.00	7.88	8.11	9.46	10.14	12.17
44	6.16	6.84	7.70	7.93	9.25	9.91	11.88
45	6.03	6.69	7.53	7.75	9.04	9.69	11.62
46	5.90	6.54	7.37	7.58	8.84	9.48	11.37
47	5.77	6.40	7.21	7.42	8.66	9.27	11.13
48	5.65	6.27	7.06	7.27	8.48	9.08	10.90
49	5.54	6.14	6.92	7.12	8.30	8.90	10.68
50	5.42	6.02	6.78	6.97	8.14	8.72	10.46
51	5.32	5.90	6.65	6.84	7.98	8.55	10.26
52	5.22	5.79	6.52	6.76	7.82	8.38	10.06
53	5.12	5.68	6.40	6.58	7.68	8.22	9.87
54	5.02	5.57	6.28	6.46	7.53	8.07	9.69
55	4.93	5.47	6.16	6.32	7.40	7.93	9.51
56	4.84	5.37	6.05	6.23	7.27	7.78	9.34
57	4.76	5.28	5.95	6.12	7.14	7.65	9.18
58	4.68	5.19	5.85	6.01	7.01	7.52	9.02
59	4.60	5.10	5.75	5.91	6.90	7.39	8.87

{167}

RING SPINNING FRAME, DRAFT TABLE.
FRONT AND BACK ROLLS SAME DIAMETER.

Front Roll Gear	27	27	27	21	27	21	21
Back Roll Gear	89	79	89	89	89	89	89
Crown Gear	72	90	90	72	108	90	108
Draft Constant	237.33	263.33	296.67	305.14	356.00	381.43	457.71
Draft Gear	Draft	Draft	Draft	Draft	Draft	Draft	Draft
32	7.42	8.23	9.27	9.54	11.13	11.92	14.30
33	7.19	7.98	8.99	9.25	10.79	11.56	13.87
34	6.98	7.75	8.73	8.97	10.47	11.22	13.46
35	6.78	7.52	8.48	8.72	10.17	10.90	13.08
36	6.59	7.31	8.24	8.48	9.89	10.60	12.71
37	6.41	7.12	8.02	8.25	9.62	10.31	12.37
38	6.25	6.93	7.81	8.03	9.37	10.04	12.05
39	6.09	6.75	7.61	7.82	9.13	9.78	11.74
40	5.93	6.58	7.42	7.63	8.90	9.54	11.44
41	5.79	6.42	7.24	7.44	8.68	9.30	11.16
42	5.65	6.27	7.06	7.27	8.48	9.08	10.90
43	5.52	6.12	6.90	7.10	8.28	8.87	10.64
44	5.39	5.98	6.74	6.94	8.09	8.67	10.40
45	5.27	5.85	6.59	6.78	7.91	8.48	10.17
46	5.16	5.72	6.45	6.63	7.74	8.29	9.95
47	5.05	5.60	6.31	6.49	7.57	8.12	9.74
48	4.94	5.49	6.18	6.36	7.42	7.94	9.54
49	4.84	5.37	6.05	6.23	7.27	7.78	9.34
50	4.75	5.27	5.93	6.10	7.12	7.63	9.15
51	4.65	5.16	5.82	5.98	6.98	7.48	8.97
52	4.56	5.06	5.71	5.86	6.85	7.34	8.80
53	4.48	4.97	5.60	5.75	6.72	7.20	8.64
54	4.40	4.88	5.49	5.65	6.59	7.06	8.48
55	4.32	4.79	5.39	5.55	6.47	6.94	8.32
56	4.24	4.70	5.30	5.45	6.36	6.81	8.17
57	4.16	4.62	5.20	5.36	6.25	6.69	8.03
58	4.09	4.54	5.11	5.26	6.14	6.58	7.89
59	4.02	4.46	5.03	5.17	6.03	6.45	7.76

{168}

RING SPINNING FRAME, TWIST CONSTANTS.

1 IN. DIA. FRONT ROLL. 7 IN. DIA. CYLINDER.

FRONT ROLL GEAR, 84 T.

Whirl on Spindle, $\frac{3}{4}$ in. Dia. Ratio Whirl to Cylinder, 8.143					
Jack Gear	Cylinder Gear	Twist Constant	Jack Gear	Cylinder Gear	Twist Constant
72	17	922.12	72	29	540.55
76	17	973.35	76	29	570.58
86	17	1101.43	86	29	645.66
96	17	1229.50	96	29	720.74
106	17	1357.57	106	29	795.81
72	21	746.48	72	39	401.95
76	21	787.95	76	39	424.28
86	21	891.63	86	39	480.11
96	21	995.31	96	39	535.93
106	21	1098.98	106	39	591.76

Whirl on Spindle, $\frac{1}{2}$ in. Dia. Ratio Whirl to Cylinder, 7.60					
Jack Gear	Cylinder Gear	Twist Constant	Jack Gear	Cylinder Gear	Twist Constant
72	17	800.65	72	29	504.52
76	17	908.46	76	29	532.55
86	17	1028.00	86	29	602.62
96	17	1147.53	96	29	672.69
106	17	1267.07	106	29	742.76
72	21	696.71	72	39	375.15
76	21	735.42	76	39	396.60
86	21	832.19	86	39	448.10
96	21	928.95	96	39	500.21
106	21	1025.72	106	39	552.31

Whirl on Spindle, $\frac{3}{8}$ in. Dia. Ratio Whirl to Cylinder, 7.125					
Jack Gear	Cylinder Gear	Twist Constant	Jack Gear	Cylinder Gear	Twist Constant
72	17	806.86	72	29	472.99
76	17	851.68	76	29	499.26
86	17	963.75	86	29	564.96
96	17	1075.81	96	29	630.65
106	17	1187.88	106	29	696.34
72	21	653.17	72	39	351.71
76	21	689.46	76	39	371.25
86	21	780.18	86	39	420.10
96	21	870.90	96	39	468.94
106	21	961.61	106	39	517.79

{169}

RING SPINNING FRAME, TWIST CONSTANTS.

1-1/16 IN. DIA. FRONT ROLL. 7 IN. DIA. CYLINDER.

FRONT ROLL GEAR, 84 T.

Whirl on Spindle, $\frac{3}{4}$ in. Dia. Ratio Whirl to Cylinder, 8.143					
Jack Gear	Cylinder Gear	Twist Constant	Jack Gear	Cylinder Gear	Twist Constant
72	17	867.89	72	29	508.76
76	17	916.11	76	29	537.03
86	17	1036.65	86	29	607.69
96	17	1157.19	96	29	678.35
106	17	1277.73	106	29	749.01
72	21	702.58	72	39	378.31
76	21	741.61	76	39	399.33
86	21	839.19	86	39	451.87
96	21	936.77	96	39	504.42
106	21	1034.35	106	39	556.96

Whirl on Spindle, $\frac{1}{2}$ in. Dia. Ratio Whirl to Cylinder, 7.60					
Jack Gear	Cylinder Gear	Twist Constant	Jack Gear	Cylinder Gear	Twist Constant
72	17	810.03	72	29	474.85
76	17	855.03	76	29	501.23
86	17	907.54	86	29	527.18
96	17	1080.04	96	29	633.13
106	17	1192.55	106	29	699.08
72	21	655.74	72	39	353.09
76	21	692.17	76	39	372.71
86	21	783.25	86	39	421.75
96	21	874.32	96	39	470.79
106	21	965.40	106	39	519.83

Whirl on Spindle, $\frac{5}{8}$ in. Dia. Ratio Whirl to Cylinder, 7.125					
Jack Gear	Cylinder Gear	Twist Constant	Jack Gear	Cylinder Gear	Twist Constant
72	17	759.41	72	29	445.17
76	17	801.59	76	29	469.90
86	17	907.07	86	29	531.73
96	17	1012.54	96	29	593.56
106	17	1118.01	106	29	655.39
72	21	614.76	72	39	331.02
76	21	648.91	76	39	349.41
86	21	734.39	86	39	395.39
96	21	819.67	96	39	441.36
106	21	905.06	106	39	487.34

{170}

RING SPINNING FRAME, TWIST CONSTANTS.**1-1/8 IN. DIA. FRONT ROLL. 7 IN. DIA. CYLINDER.****FRONT ROLL GEAR, 84 T.**

Whirl on Spindle, $\frac{3}{8}$ in. Dia. Ratio Whirl to Cylinder, 8.143					
Jack Gear	Cylin-der Gear	Twist Constant	Jack Gear	Cylin-der Gear	Twist Constant
72	17	819.67	72	29	480.49
76	17	865.20	76	29	507.19
86	17	979.04	86	29	573.92
96	17	1092.89	96	29	640.66
106	17	1206.73	106	29	707.39
72	21	663.54	72	39	357.29
76	21	700.40	76	39	377.14
86	21	792.56	86	39	426.76
96	21	884.72	96	39	476.38
106	21	976.88	106	39	526.01

Whirl on Spindle, $\frac{1}{2}$ in. Dia. Ratio Whirl to Cylinder, 7.60					
Jack Gear	Cylin-der Gear	Twist Constant	Jack Gear	Cylin-der Gear	Twist Constant
72	17	765.02	72	29	448.46
76	17	807.52	76	29	473.37
86	17	913.77	86	29	535.66
96	17	1020.02	96	29	597.95
106	17	1126.28	106	29	660.23
72	21	619.30	72	39	333.47
76	21	653.71	76	39	351.99
86	21	739.72	86	39	398.31
96	21	825.73	96	39	444.63
106	21	911.75	106	39	490.94

Whirl on Spindle, $\frac{5}{8}$ in. Dia. Ratio Whirl to Cylinder, 7.125					
Jack Gear	Cylin-der Gear	Twist Constant	Jack Gear	Cylin-der Gear	Twist Constant
72	17	717.20	72	29	420.43
76	17	757.05	76	29	443.70
86	17	856.66	86	29	502.18
96	17	956.27	96	29	560.57
106	17	1055.89	106	29	618.96
72	21	580.59	72	39	312.63
76	21	612.85	76	39	330.00
86	21	693.49	86	39	373.42
96	21	774.13	96	39	416.84
106	21	854.76	106	39	460.26

{171}

RING SPINNING FRAME TWIST TABLE.**1 IN. DIA. FRONT ROLL. 7 IN. DIA. CYLINDER.****FRONT ROLL GEAR, 84 T.**

Twist Change Gear	Whirl on Spindle, $\frac{3}{4}$ in. Dia. Ratio Whirl to Cylinder, 8.143								
	Jack 72 Cyl. 17	Jack 86 Cyl. 17	Jack 96 Cyl. 17	Jack 106 Cyl. 17	Jack 72 Cyl. 21	Jack 76 Cyl. 21	Jack 86 Cyl. 21	Jack 96 Cyl. 21	Jack 106 Cyl. 21
	Twist	Twist	Twist	Twist	Twist	Twist	Twist	Twist	Twist
25	36.89	44.06	49.18	54.30	29.86	31.12	35.67	39.81	43.96
26	35.47	42.36	47.28	52.21	28.71	30.31	34.29	38.28	42.27
27	34.15	40.79	45.54	50.28	27.65	29.18	33.02	36.86	40.70
28	32.93	39.34	43.84	48.48	26.66	28.14	31.84	35.55	39.25
29	31.80	37.98	42.40	46.81	25.74	27.17	30.75	34.32	37.90
30	30.74	36.71	40.98	45.25	24.85	26.27	29.72	33.18	36.63
31	29.75	35.53	39.60	43.79	24.08	25.42	28.76	32.11	35.45
32	28.82	34.42	38.42	42.42	23.32	24.62	27.86	31.10	34.34
33	27.94	33.38	37.26	41.14	22.62	23.88	27.02	30.16	33.24
34	27.12	32.39	36.16	39.93	21.96	23.18	26.22	29.27	32.22
35	26.35	31.47	35.13	38.79	21.33	22.51	25.48	28.43	31.40
36	25.61	30.60	34.15	37.71	20.74	21.89	24.77	27.65	30.53
37	24.92	29.77	33.23	36.69	20.18	21.30	24.10	26.90	29.70
38	24.27	28.98	32.36	35.73	19.64	20.74	23.46	26.19	28.92
39	23.64	28.24	31.53	34.81	19.14	20.20	22.86	25.52	28.18
40	23.05	27.54	30.74	33.94	18.66	19.70	22.29	24.88	27.47
41	22.49	26.86	29.90	33.11	18.21	19.22	21.75	24.28	26.80
42	21.96	26.22	29.27	32.32	17.77	18.76	21.23	23.70	26.26
43	21.44	25.61	28.59	31.57	17.36	18.32	20.74	23.15	25.56
44	20.96	25.03	27.94	30.85	16.97	17.91	20.26	22.62	24.98
45	20.49	24.48	27.32	30.17	16.59	17.51	19.81	22.12	24.42
46	20.05	23.94	26.73	29.51	16.23	17.13	19.60	21.64	23.89
47	19.62	23.43	26.18	28.88	15.88	16.78	18.97	21.18	23.38
48	19.21	22.97	25.61	28.28	15.55	16.42	18.58	20.76	22.90
49	18.82	22.54	25.09	27.70	15.23	16.08	18.20	20.31	22.43
50	18.44	22.08	24.59	27.15	14.93	15.76	17.83	19.91	21.98
51	18.08	21.60	24.11	26.62	14.64	15.45	17.48	19.52	21.55
52	17.73	21.18	23.64	26.11	14.36	15.15	17.15	19.14	21.13
53	17.40	20.78	23.20	25.63	14.05	14.87	16.88	18.78	20.74
54	17.08	20.40	22.77	25.14	13.82	14.59	16.51	18.43	20.35
55	16.77	20.03	22.35	24.65	13.57	14.33	16.21	18.10	19.98
56	16.47	19.70	21.96	24.24	13.33	14.07	15.92	17.77	19.62
57	16.18	19.32	21.57	23.82	13.10	13.82	15.64	17.46	19.28
58	15.90	18.99	21.20	23.40	12.87	13.59	15.37	17.16	18.95
59	15.61	18.67	20.84	23.01	12.65	13.36	15.11	16.95	18.63
60	15.37	18.36	20.49	22.63	12.27	13.13	14.86	16.59	18.32
61	15.12	18.06	20.16	22.26	12.24	12.92	14.62	16.32	18.02
62	14.87	17.76	19.83	21.90	12.04	12.71	14.38	16.05	17.73
63	14.64	17.50	19.52	21.55	11.85	12.51	14.15	15.80	17.44
64	14.41	17.21	19.21	21.21	11.66	12.31	13.93	15.55	17.17
65	14.19	16.95	18.90	20.89	11.48	12.12	13.72	15.31	16.91
66	13.97	16.69	18.63	20.57	11.31	11.94	13.51	15.08	16.62
67	13.76	16.44	18.35	20.26	11.14	11.76	13.31	14.88	16.40

{172}

RING SPINNING FRAME TWIST TABLE.

1 IN. DIA. FRONT ROLL. 7 IN. DIA. CYLINDER.

FRONT ROLL GEAR, 84 T.

Twist Change Gear	Whirl on Spindle, $\frac{1}{8}$ in. Dia. Ratio Whirl to Cylinder, 7.60								
	Jack 72 Cyl. 17	Jack 86 Cyl. 17	Jack 96 Cyl. 17	Jack 106 Cyl. 17	Jack 72 Cyl. 21	Jack 76 Cyl. 21	Jack 86 Cyl. 21	Jack 96 Cyl. 21	Jack 106 Cyl. 21
	Twist	Twist	Twist	Twist	Twist	Twist	Twist	Twist	Twist
25	34.43	41.12	45.90	50.68	27.87	29.42	33.29	37.16	41.03
26	33.10	39.54	44.14	48.73	26.80	28.29	32.01	35.71	39.45
27	31.88	38.07	42.50	46.93	25.80	27.24	30.82	34.41	37.99
28	30.74	36.71	40.98	45.25	24.88	26.27	29.72	33.18	36.63
29	29.68	35.45	39.57	43.69	24.02	25.36	28.70	32.03	35.37
30	28.69	34.27	38.25	42.24	23.22	24.51	27.74	30.97	34.19
31	27.76	33.16	37.02	40.87	22.47	23.72	26.84	29.97	33.09
32	26.90	32.13	35.85	39.60	21.77	22.98	26.01	29.03	32.05
33	26.08	31.15	34.77	38.40	21.11	22.29	25.22	28.15	31.08
34	25.31	30.24	33.75	37.27	20.49	21.63	24.48	27.32	30.17
35	24.59	29.37	32.79	36.20	19.91	21.01	23.78	26.54	29.31
36	23.91	28.56	31.88	35.19	19.35	20.43	23.11	25.80	28.49
37	23.26	27.78	31.01	34.25	18.83	19.88	22.49	25.11	27.72
38	22.65	27.05	30.20	33.34	18.33	19.35	21.90	24.48	26.99
39	22.07	26.36	29.42	32.49	17.86	18.86	21.34	23.82	26.30
40	21.52	25.70	28.69	31.68	17.42	18.39	20.80	23.22	25.64
41	20.99	25.07	27.99	30.90	16.99	17.94	20.30	22.66	25.02
42	20.49	24.48	27.32	30.17	16.59	17.51	19.81	22.12	24.42
43	20.02	23.91	26.69	29.47	16.20	17.10	19.35	21.60	23.85
44	19.56	23.36	26.08	28.80	15.83	16.71	18.91	21.11	23.31
45	19.13	22.84	25.50	28.16	15.48	16.34	18.49	20.64	22.79
46	18.71	22.35	24.95	27.55	15.15	15.99	18.09	20.19	22.30
47	18.31	21.87	24.42	26.96	14.82	15.65	17.71	19.76	21.82
48	17.93	21.42	23.91	26.40	14.51	15.32	17.34	19.34	21.37
49	17.56	20.98	23.42	25.86	14.22	15.01	16.98	18.96	20.93
50	17.21	20.56	22.95	25.34	13.93	14.71	16.64	18.58	20.51
51	16.88	20.11	22.50	24.84	13.66	14.42	16.32	18.21	20.11
52	16.55	19.77	22.07	24.36	13.40	14.14	16.00	17.86	19.72
53	16.24	19.40	21.65	23.91	13.15	13.88	15.70	17.53	19.35
54	15.94	19.04	21.25	23.46	12.90	13.62	15.41	17.20	19.00
55	15.65	18.69	20.86	23.04	12.67	13.37	15.13	16.89	18.65
56	15.37	18.36	20.49	22.63	12.44	13.13	14.86	16.59	18.32
57	15.10	18.04	20.13	22.23	12.22	12.90	14.60	16.30	18.00
58	14.84	17.72	19.79	21.85	12.01	12.68	14.35	16.02	17.68
59	14.59	17.42	19.45	21.48	11.81	12.46	14.10	15.74	17.38
60	14.34	17.13	19.13	21.12	11.61	12.26	13.87	15.48	17.10
61	14.11	16.85	18.81	20.77	11.42	12.06	13.64	15.23	16.81
62	13.88	16.58	18.51	20.44	11.24	11.86	13.42	14.98	16.54
63	13.66	16.32	18.21	20.11	11.06	11.67	13.21	14.75	16.28
64	13.48	16.06	17.93	19.80	10.89	11.49	13.00	14.51	16.03
65	13.27	15.82	17.65	19.49	10.72	11.31	12.80	14.29	15.78
66	13.04	15.58	17.54	19.20	10.56	11.14	12.61	14.08	15.54
67	12.85	15.34	17.13	18.91	10.40	10.98	12.42	13.87	15.31

{173}

RING SPINNING FRAME TWIST TABLE.

1 IN. DIA. FRONT ROLL. 7 IN. DIA. CYLINDER.

FRONT ROLL GEAR, 84 T.

Twist Change Gear	Whirl on Spindle, $\frac{13}{16}$ in. Dia. Ratio Whirl to Cylinder, 7.60								
	Jack 72 Cyl. 29	Jack 76 Cyl. 29	Jack 80 Cyl. 29	Jack 90 Cyl. 29	Jack 106 Cyl. 29	Jack 72 Cyl. 39	Jack 76 Cyl. 39	Jack 86 Cyl. 39	Jack 96 Cyl. 39
	Twist	Twist	Twist	Twist	Twist	Twist	Twist	Twist	Twist
25	20.18	21.30	23.10	25.91	29.71	15.01	15.84	17.92	20.01
26	19.40	20.48	23.18	25.87	28.57	14.43	15.23	17.23	19.24
27	18.69	19.72	22.32	24.91	27.51	13.89	14.67	16.60	18.53
28	18.02	19.02	21.52	24.02	26.53	13.40	14.14	16.00	17.86
29	17.40	18.30	20.78	23.20	25.61	12.94	13.66	15.45	17.25
30	16.82	17.75	20.09	22.42	24.76	12.51	13.20	14.94	16.67
31	16.27	17.18	19.44	21.70	23.96	12.10	12.77	14.45	16.14
32	15.77	16.64	18.83	21.02	23.21	11.72	12.37	14.00	15.63
33	15.29	16.14	18.26	20.38	22.51	11.37	12.00	13.58	15.16
34	14.84	15.66	17.72	19.79	21.85	11.03	11.65	13.18	14.71
35	14.41	15.22	17.22	19.22	21.22	10.72	11.31	12.80	14.29
36	14.01	14.79	16.74	18.69	20.63	10.42	11.00	12.45	13.89
37	13.64	14.39	16.28	18.18	20.07	10.14	10.70	12.11	13.52
38	13.28	14.01	15.86	17.70	19.55	9.87	10.42	11.79	13.16
39	12.94	13.66	15.45	17.25	19.05	9.62	10.15	11.49	12.83
40	12.61	13.31	15.07	16.82	18.57	9.38	9.90	11.20	12.51
41	12.31	12.99	14.70	16.41	18.12	9.15	9.66	10.93	12.25
42	12.01	12.68	14.35	16.02	17.68	8.93	9.43	10.67	11.91
43	11.73	12.40	14.01	15.64	17.27	8.72	9.21	10.42	11.63
44	11.46	12.10	13.70	15.29	16.88	8.53	9.00	10.18	11.37
45	11.21	11.83	13.39	14.95	16.51	8.34	8.80	9.96	11.12
46	10.97	11.58	13.10	14.62	16.15	8.16	8.61	9.74	10.87
47	10.73	11.33	12.82	14.31	15.80	7.98	8.43	9.53	10.64
48	10.51	11.09	12.55	14.01	15.47	7.82	8.25	9.34	10.42
49	10.29	10.87	12.30	13.73	15.16	7.66	8.08	9.12	10.21
50	10.09	10.65	12.05	13.45	14.86	7.50	7.92	8.96	10.00
51	9.89	10.44	11.82	13.19	14.56	7.35	7.76	8.79	9.81
52	9.70	10.24	11.59	12.94	14.28	7.21	7.62	8.62	9.62
53	9.52	10.05	11.37	12.69	14.01	7.08	7.47	8.45	9.44
54	9.34	9.86	11.16	12.46	13.75	6.95	7.33	8.30	9.26
55	9.17	9.68	10.96	12.23	13.50	6.82	7.20	8.15	9.09
56	9.01	9.51	10.76	12.01	13.26	6.69	7.07	8.00	8.93
57	8.85	9.34	10.57	11.80	13.03	6.58	6.95	7.86	8.78
58	8.70	9.18	10.39	11.60	12.81	6.47	6.83	7.73	8.62
59	8.55	9.03	10.21	11.40	12.59	6.36	6.71	7.59	8.48
60	8.41	8.88	10.04	11.21	12.38	6.25	6.60	7.47	8.34
61	8.27	8.73	9.88	11.03	12.18	6.15	6.49	7.35	8.20
62	8.14	8.59	9.72	10.85	11.98	6.05	6.39	7.23	8.06
63	8.01	8.45	9.57	10.68	11.79	5.95	6.29	7.11	7.94
64	7.88	8.32	9.42	10.51	11.61	5.86	6.19	7.00	7.82
65	7.76	8.19	9.27	10.35	11.43	5.77	6.09	6.89	7.70
66	7.64	8.07	9.13	10.19	11.25	5.68	6.00	6.79	7.58
67	7.53	7.95	8.99	10.04	11.09	5.60	5.91	6.69	7.47

{174}

RING SPINNING FRAME TWIST TABLE.

1 IN. DIA. FRONT ROLL. 7 IN. DIA. CYLINDER.

FRONT ROLL GEAR, 84 T.

Twist Change Gear	Whirl on Spindle, $\frac{7}{8}$ in. Dia. Ratio Whirl to Cylinder, 7.125								
	Jack 96 Cyl. 17	Jack 72 Cyl. 21	Jack 76 Cyl. 21	Jack 86 Cyl. 21	Jack 96 Cyl. 21	Jack 72 Cyl. 29	Jack 86 Cyl. 29	Jack 72 Cyl. 39	Jack 86 Cyl. 39
	Twist	Twist	Twist	Twist	Twist	Twist	Twist	Twist	Twist
25	43.03	26.13	27.58	31.21	34.44	18.92	22.60	14.07	16.80
26	41.38	25.12	26.52	30.01	33.50	18.19	21.73	13.53	16.16
27	39.84	24.19	25.54	28.90	32.26	17.52	20.92	13.02	15.56
28	38.42	23.33	24.62	27.86	31.10	16.89	20.18	12.56	15.00
29	37.10	22.52	23.77	26.90	30.03	16.31	19.48	12.13	14.49
30	35.86	21.77	22.98	26.01	29.03	15.77	18.83	11.72	14.00
31	34.70	21.07	22.24	25.17	28.09	15.26	18.22	11.35	13.55
32	33.62	20.41	21.55	24.38	27.21	14.78	17.65	10.99	13.13
33	32.60	19.79	20.89	23.64	26.39	14.33	17.12	10.66	12.73
34	31.64	19.21	20.28	22.95	25.61	13.91	16.62	10.34	12.36
35	30.74	18.66	19.70	22.30	24.88	13.51	16.14	10.05	12.00
36	29.88	18.14	19.15	21.67	24.19	13.14	15.69	9.77	11.67
37	29.08	17.65	18.63	21.09	23.54	12.78	15.27	9.51	11.38
38	28.31	17.19	18.14	20.53	22.92	12.45	14.87	9.26	11.06
39	27.58	16.75	17.68	20.00	22.33	12.13	14.49	9.02	10.77
40	26.90	16.33	17.24	19.50	21.77	11.82	14.12	8.79	10.50
41	26.24	15.93	16.82	19.03	21.29	11.54	13.78	8.58	10.25
42	25.61	15.55	16.42	18.58	20.71	11.26	13.40	8.37	10.00
43	25.02	15.19	16.03	18.12	20.25	11.00	13.14	8.18	9.77
44	24.45	14.84	15.67	17.73	19.79	10.75	12.84	7.99	9.55
45	23.91	14.51	15.32	17.34	19.35	10.51	12.55	7.81	9.34
46	23.39	14.20	14.99	16.96	18.93	10.28	12.28	7.65	9.13
47	22.89	13.90	14.67	16.60	18.54	10.06	12.02	7.48	8.94
48	22.41	13.61	14.36	16.25	18.14	9.85	11.77	7.33	8.75
49	21.96	13.33	14.07	15.92	17.77	9.65	11.53	7.18	8.57
50	21.51	13.06	13.79	15.60	17.42	9.46	11.30	7.03	8.40
51	21.09	12.81	13.52	15.30	17.08	9.27	11.08	6.90	8.24
52	20.69	12.56	13.26	15.00	16.74	9.10	10.86	6.76	8.08
53	20.30	12.32	13.01	14.72	16.43	8.92	10.66	6.64	7.93
54	19.92	12.10	12.77	14.45	16.13	8.76	10.46	6.51	7.78
55	19.56	11.88	12.54	14.19	15.83	8.60	10.27	6.39	7.64
56	19.21	11.66	12.31	13.93	15.55	8.44	10.09	6.28	7.50
57	18.87	11.46	12.10	13.69	15.28	8.30	9.91	6.17	7.37
58	18.55	11.26	11.89	13.45	15.02	8.15	9.74	6.06	7.24
59	18.23	11.07	11.69	13.22	14.76	8.02	9.58	5.96	7.12
60	17.93	10.89	11.49	13.00	14.51	7.88	9.42	5.86	7.00
61	17.64	10.71	11.30	12.79	14.28	7.75	9.26	5.77	6.89
62	17.35	10.54	11.12	12.58	14.05	7.63	9.11	5.67	6.79
63	17.08	10.37	10.94	12.38	13.82	7.51	8.97	5.58	6.67
64	16.81	10.21	10.77	12.19	13.61	7.39	8.83	5.50	6.56
65	16.55	10.05	10.61	12.00	13.40	7.28	8.69	5.41	6.46
66	16.30	9.90	10.45	11.82	13.20	7.17	8.56	5.33	6.36
67	16.07	9.75	10.29	11.64	13.00	7.06	8.43	5.25	6.27

{175}

RING SPINNING FRAME TWIST TABLE.

**1-1/16 IN. DIA. FRONT ROLL.
7 IN. DIA. CYLINDER.
FRONT ROLL GEAR, 84 T.**

Twist Change Gear	Whirl on Spindle, $\frac{3}{8}$ in. Dia. Ratio Whirl to Cylinder, 8.143					Whirl on Spin., $\frac{11}{16}$ in. Dia. Ratio Whirl to Cyl., 7.60			
	Jack 76 Cyl. 21	Jack 72 Cyl. 17	Jack 106 Cyl. 21	Jack 86 Cyl. 17	Jack 106 Cyl. 17	Jack 76 Cyl. 21	Jack 72 Cyl. 17	Jack 86 Cyl. 17	Jack 96 Cyl. 17
	Twist	Twist	Twist	Twist	Twist	Twist	Twist	Twist	Twist
25	29.66	34.72	41.37	41.46	51.11	27.69	32.40	38.70	43.22
26	28.52	33.38	39.78	39.87	49.14	26.62	31.16	37.21	41.56
27	27.47	32.14	38.31	38.39	47.32	25.64	30.00	35.83	40.62
28	26.49	31.00	36.94	37.02	45.63	24.72	28.93	34.55	38.59
29	25.57	29.93	35.67	35.75	44.06	23.87	27.93	33.36	37.26
30	24.72	28.93	34.48	34.55	42.59	23.07	27.00	32.25	36.01
31	23.92	28.00	33.37	33.44	41.22	22.33	26.13	31.21	34.85
32	23.18	27.12	32.32	32.39	39.93	21.63	25.31	30.24	33.76
33	22.47	26.30	31.34	31.41	38.72	20.97	24.55	29.32	32.74
34	21.81	25.53	30.42	30.49	37.58	20.36	23.82	28.46	31.78
35	21.19	24.80	29.55	29.62	36.51	19.78	23.14	27.64	30.87
36	20.60	24.11	28.73	28.80	35.49	19.23	22.50	26.88	30.01
37	20.04	23.46	27.96	28.02	34.53	18.71	21.89	26.15	29.20
38	19.52	22.84	27.22	27.28	33.62	18.21	21.32	25.46	28.43
39	19.02	22.25	26.52	26.58	32.76	17.75	20.77	24.81	27.70
40	18.54	21.70	25.86	25.92	31.94	17.30	20.25	24.19	27.01
41	18.09	21.17	25.23	25.28	31.16	16.88	19.76	23.60	26.35
42	17.66	20.66	24.63	24.68	30.42	16.48	19.29	23.04	25.72
43	17.25	20.18	24.05	24.11	29.71	16.10	18.84	22.50	25.13
44	16.85	19.72	23.51	23.56	29.04	15.73	18.41	21.99	24.56
45	16.48	19.29	22.99	23.04	28.39	15.38	18.00	21.50	24.01
46	16.12	18.87	22.49	22.54	27.78	15.05	17.61	21.03	23.49
47	15.78	18.47	22.01	22.06	27.19	14.73	17.23	20.59	22.99
48	15.45	18.08	21.55	21.60	26.62	14.42	16.88	20.16	22.51
49	15.13	17.71	21.11	21.16	26.08	14.13	16.53	19.75	22.05
50	14.83	17.36	20.69	20.73	25.55	13.84	16.20	19.35	21.61
51	14.54	17.02	20.28	20.33	25.05	13.57	15.88	18.97	21.18
52	14.26	16.69	19.89	19.94	24.57	13.31	15.58	18.61	20.78
53	13.99	16.38	19.52	19.56	24.11	13.06	15.28	18.26	20.39
54	13.73	16.07	19.15	19.20	23.66	12.82	15.00	17.92	20.01
55	13.48	15.78	18.81	18.85	23.23	12.58	14.73	17.59	19.64
56	13.24	15.50	18.47	18.51	22.82	12.36	14.46	17.28	19.29
57	13.01	15.23	18.15	18.19	22.42	12.14	14.21	16.97	18.96
58	12.79	14.96	17.83	17.87	22.03	11.93	13.97	16.68	18.63
59	12.57	14.71	17.53	17.57	21.66	11.73	13.73	16.40	18.31
60	12.36	14.46	17.24	17.28	21.30	11.54	13.50	16.13	18.01
61	12.16	14.23	16.96	16.99	20.95	11.35	13.28	15.86	17.71
62	11.96	14.00	16.68	16.72	20.61	11.16	13.07	15.61	17.43
63	11.77	13.78	16.42	16.45	20.28	10.99	12.86	15.36	17.15
64	11.59	13.56	16.16	16.20	19.96	10.81	12.66	15.12	16.88
65	11.41	13.35	15.91	15.95	19.66	10.65	12.46	14.89	16.62
66	11.24	13.15	15.67	15.71	19.36	10.49	12.27	14.66	16.37
67	11.07	12.95	15.44	15.47	19.07	10.33	12.09	14.44	16.13

{176}

YARN TWIST TABLES.

Counts or Numbers	Square Root	Standard Warp Twist	Warp Twist	Extra Filling Twist	Filling or Hosiery Twist	Soft Hosiery Twist	Underwear Twist
1	1.0000	4.75	4.50	3.50	3.25	3.00	2.75
2	1.4142	6.72	6.36	4.95	4.60	4.24	3.89
3	1.7321	8.23	7.79	6.06	5.63	5.20	4.76
4	2.0000	9.50	9.00	7.00	6.50	6.00	5.50
5	2.2361	10.62	10.06	7.83	7.27	6.71	6.15
6	2.4495	11.63	11.02	8.57	7.96	7.35	6.74
7	2.6458	12.56	11.91	9.26	8.60	7.94	7.27
8	2.8284	13.43	12.73	9.90	9.19	8.48	7.78
9	3.0000	14.25	13.50	10.50	9.75	9.00	8.25
10	3.1623	15.02	14.23	11.07	10.28	9.49	8.69
11	3.3166	15.75	14.92	11.61	10.78	9.95	9.12
12	3.4641	16.45	15.59	12.12	11.26	10.39	9.52
13	3.6056	17.12	16.22	12.62	11.72	10.82	9.91
14	3.7417	17.77	16.84	13.10	12.16	11.22	10.29
15	3.8730	18.39	17.43	13.56	12.59	11.62	10.65
16	4.0000	19.00	18.00	14.00	13.00	12.00	11.00
17	4.1231	19.58	18.55	14.43	13.40	12.37	11.34
18	4.2426	20.15	19.09	14.85	13.79	12.73	11.66
19	4.3589	20.70	19.62	15.26	14.17	13.07	11.98
20	4.4721	21.24	20.12	15.65	14.53	13.41	12.30
21	4.5826	21.76	20.62	16.04	14.89	13.75	12.60
22	4.6904	22.27	21.11	16.42	15.24	14.07	12.89
23	4.7958	22.78	21.58	16.79	15.59	14.39	13.19
24	4.8990	23.27	22.05	17.15	15.92	14.70	13.47
25	5.0000	23.75	22.50	17.50	16.25	15.00	13.75
26	5.0990	24.22	22.95	17.85	16.57	15.30	14.02
27	5.1962	24.68	23.38	18.19	16.89	15.59	14.29
28	5.2915	25.13	23.81	18.52	17.20	15.87	14.55
29	5.3852	25.58	24.23	18.85	17.50	16.15	14.81
30	5.4772	26.02	24.65	19.17	17.80	16.43	15.06
31	5.5678	26.44	25.05	19.49	18.10	16.70	15.31
32	5.6569	26.87	25.46	19.80	18.38	16.97	15.55
33	5.7446	27.28	25.85	20.11	18.67	17.23	15.80
34	5.8310	27.69	26.24	20.41	18.95	17.49	16.03
35	5.9161	28.10	26.62	20.71	19.23	17.75	16.27
36	6.0000	28.50	27.00	21.00	19.50	18.00	16.50
37	6.0828	28.89	27.37	21.29	19.77	18.25	16.72
38	6.1644	29.28	27.74	21.58	20.03	18.49	16.95
39	6.2450	29.66	28.10	21.86	20.30	18.73	17.17
40	6.3246	30.04	28.46	22.14	20.55	18.97	17.39
41	6.4031	30.41	28.81	22.41	20.81	19.21	17.61
42	6.4807	30.78	29.16	22.68	21.06	19.44	17.82
43	6.5574	31.15	29.51	22.95	21.31	19.67	18.03
44	6.6332	31.51	29.85	23.22	21.56	19.90	18.24
45	6.7082	31.86	30.19	23.48	21.80	20.12	18.45
46	6.7823	32.22	30.52	23.74	22.04	20.35	18.65
47	6.8557	32.56	30.85	23.99	22.28	20.57	18.85
48	6.9282	32.91	31.18	24.25	22.52	20.78	19.05
49	7.0000	33.25	31.50	24.50	22.75	21.00	19.25
50	7.0711	33.59	31.82	24.75	22.98	21.21	19.44

{177}

YARN TWIST TABLES.

Counts of Numbers	Square Root	Standard Warp Twist	Warp Twist	Extra Filling Twist	Filling or Hosiery Twist	Soft Hosiery Twist	Underwear Twist
1	1.0000	4.75	4.50	3.50	3.25	3.00	2.75
51	7.1414	33.92	32.14	24.90	23.21	21.42	19.64
52	7.2111	34.25	32.45	25.24	23.44	21.63	19.83
53	7.2801	34.58	32.76	25.48	23.66	21.84	20.02
54	7.3485	34.91	33.07	25.72	23.88	22.04	20.21
55	7.4162	35.23	33.37	25.96	24.10	22.25	20.39
56	7.4833	35.55	33.67	26.19	24.32	22.45	20.58
57	7.5498	35.86	33.97	26.42	24.54	22.65	20.76
58	7.6158	36.17	34.27	26.66	24.75	22.85	20.94
59	7.6811	36.49	34.57	26.88	24.96	23.04	21.12
60	7.7460	36.79	34.86	27.11	25.17	23.24	21.30
61	7.8102	37.10	35.15	27.34	25.38	23.43	21.48
62	7.8740	37.40	35.43	27.56	25.59	23.62	21.65
63	7.9373	37.70	35.72	27.78	25.80	23.81	21.83
64	8.0000	38.00	36.00	28.00	26.00	24.00	22.00
65	8.0623	38.30	36.28	28.22	26.20	24.19	22.17
66	8.1240	38.59	36.56	28.43	26.40	24.37	22.34
67	8.1854	38.88	36.83	28.65	26.60	24.55	22.51
68	8.2462	39.17	37.11	28.86	26.80	24.74	22.68
69	8.3066	39.46	37.38	29.07	27.00	24.92	22.84
70	8.3666	39.74	37.65	29.28	27.19	25.10	23.01
71	8.4261	40.02	37.92	29.49	27.38	25.28	23.17
72	8.4853	40.31	38.18	29.70	27.58	25.45	23.33
73	8.5440	40.58	38.45	29.90	27.77	25.63	23.50
74	8.6023	40.86	38.71	30.11	27.96	25.81	23.66
75	8.6603	41.14	38.97	30.31	28.15	25.98	23.82
76	8.7178	41.41	39.23	30.51	28.33	26.15	23.97
77	8.7750	41.68	39.49	30.71	28.52	26.32	24.13
78	8.8318	41.95	39.74	30.91	28.70	26.49	24.29
79	8.8882	42.22	40.00	31.11	28.89	26.66	24.44
80	8.9443	42.49	40.25	31.30	29.07	26.83	24.60
81	9.0000	42.75	40.50	31.50	29.25	27.00	24.75
82	9.0554	43.01	40.75	31.69	29.43	27.16	24.90
83	9.1104	43.27	41.00	31.89	29.61	27.33	25.05
84	9.1652	43.53	41.24	32.08	29.79	27.49	25.20
85	9.2195	43.79	41.49	32.27	29.96	27.66	25.35
86	9.2736	44.05	41.73	32.46	30.14	27.82	25.50
87	9.3274	44.31	41.97	32.65	30.31	27.98	25.65
88	9.3808	44.56	42.21	32.83	30.49	28.14	25.80
89	9.4340	44.81	42.45	33.02	30.66	28.30	25.94
90	9.4868	45.06	42.69	33.20	30.83	28.46	26.09
91	9.5394	45.31	42.93	33.39	31.00	28.62	26.23
92	9.5917	45.56	43.16	33.57	31.17	28.77	26.38
93	9.6437	45.81	43.40	33.75	31.34	28.93	26.52
94	9.6954	46.05	43.63	33.93	31.51	29.09	26.66
95	9.7468	46.30	43.86	34.11	31.68	29.24	26.80
96	9.7980	46.54	44.09	34.29	31.84	29.39	26.94
97	9.8489	46.78	44.32	34.47	32.01	29.55	27.08
98	9.8995	47.02	44.55	34.65	32.17	29.70	27.22
99	9.9499	47.26	44.77	34.82	32.34	29.85	27.36
100	10.0000	47.50	45.00	35.00	32.50	30.00	27.50

{178}

YARN TWIST TABLES.

Counts or Numbers	Square Root	Standard Warp Twist	Warp Twist	Extra Filling Twist	Filling or Hosiery Twist	Soft Hosiery Twist	Underwear Twist
1	1.0000	4.75	4.50	3.50	3.25	3.00	2.75
101	10.0499	47.74	45.22	35.17	32.66	30.15	27.64
102	10.0995	47.97	45.45	35.35	32.82	30.30	27.77
103	10.1489	48.21	45.67	35.52	32.98	30.45	27.91
104	10.1980	48.44	45.89	35.69	33.14	30.59	28.04
105	10.2470	48.67	46.11	35.86	33.30	30.74	28.18
106	10.2956	48.90	46.33	36.03	33.46	30.89	28.31
107	10.3441	49.13	46.55	36.20	33.62	31.03	28.44
108	10.3923	49.36	46.77	36.37	33.77	31.19	28.58
109	10.4403	49.59	46.98	36.54	33.93	31.32	28.71
110	10.4881	49.82	47.20	36.71	34.09	31.46	28.84
111	10.5357	50.04	47.41	36.87	34.24	31.61	28.97
112	10.5830	50.27	47.62	37.04	34.39	31.75	29.10
113	10.6301	50.49	47.84	37.21	34.55	31.89	29.23
114	10.6771	50.72	48.05	37.37	34.70	32.03	29.36
115	10.7238	50.94	48.26	37.53	34.85	32.17	29.49
116	10.7703	51.16	48.47	37.70	35.00	32.31	29.62
117	10.8167	51.38	48.67	37.86	35.15	32.45	29.75
118	10.8628	51.60	48.88	38.02	35.30	32.59	29.87
119	10.9087	51.82	49.09	38.18	35.45	32.73	30.00
120	10.9545	52.03	49.30	38.34	35.60	32.86	30.12
121	11.0000	52.25	49.50	38.50	35.75	33.00	30.25
122	11.0454	52.47	49.70	38.66	35.90	33.14	30.37
123	11.0905	52.68	49.91	38.82	36.04	33.27	30.50
124	11.1355	52.89	50.11	38.97	36.19	33.41	30.62
125	11.1803	53.11	50.31	39.13	36.34	33.54	30.75
126	11.2250	53.32	50.51	39.29	36.48	33.67	30.87
127	11.2694	53.53	50.71	39.44	36.63	33.81	30.99
128	11.3137	53.74	50.91	39.60	36.77	33.94	31.11
129	11.3578	53.95	51.12	39.75	36.91	34.07	31.23
130	11.4018	54.16	51.31	39.91	37.06	34.20	31.35
131	11.4455	54.37	51.50	40.06	37.20	34.34	31.48
132	11.4891	54.57	51.70	40.21	37.34	34.47	31.60
133	11.5326	54.78	51.90	40.36	37.48	34.60	31.71
134	11.5758	54.99	52.09	40.52	37.62	34.73	31.83
135	11.6190	55.19	52.29	40.67	37.76	34.86	31.95
136	11.6619	55.39	52.48	40.82	37.90	34.98	32.07
137	11.7047	55.60	52.67	40.97	38.04	35.11	32.19
138	11.7473	55.80	52.86	41.12	38.18	35.24	32.31
139	11.7898	56.00	53.05	41.26	38.32	35.37	32.42
140	11.8322	56.20	53.24	41.41	38.45	35.50	32.54
141	11.8743	56.40	53.43	41.56	38.59	35.62	32.65
142	11.9164	56.60	53.62	41.71	38.73	35.75	32.77
143	11.9583	56.80	53.81	41.85	38.86	35.87	32.89
144	12.0000	57.00	54.00	42.00	39.00	36.00	33.00
145	12.0416	57.20	54.19	42.15	39.14	36.12	33.11
146	12.0830	57.39	54.37	42.29	39.27	36.25	33.23
147	12.1244	57.59	54.56	42.44	39.40	36.37	33.34
148	12.1655	57.79	54.74	42.58	39.54	36.50	33.46
149	12.2066	57.98	54.93	42.72	39.67	36.62	33.57
150	12.2474	58.18	55.11	42.87	39.80	36.74	33.68

NOTE—The above tables are extended in some cases much beyond the actual requirements as indicated by their headings, but will prove useful for other yarns.

{179}

TABLE FOR NUMBERING COTTON YARN BY THE WEIGHT IN GRAINS OF 120 YARDS OR 1 SKEIN

120 Yds. Weigh Grains	No. of Yarn	120 Yds. Weigh Grains	No. of Yarn	120 Yds. Weigh Grains	No. of Yarn	120 Yds. Weigh Grains	No. of Yarn	120 Yds. Weigh Grains	No. of Yarn				
		12		17		22		28					
1	1000	.3	81.30	.6	56.82	.9	43.67	.2	35.46				
2	500	.4	80.65	.7	56.50		43.48	.3	35.34				
3	333.3	.5	80.00	.8	56.18	23	.1	43.29	.4	35.21			
4	250.0	.6	79.37	.9	55.87		.2	43.10	.5	35.09			
5	200.0	.7	78.74		55.56		.3	42.92	.6	34.97			
5.5	181.8	.8	78.12	18	.1	55.25	.4	42.74	.7	34.84			
6	166.7	.9	77.52		.2	54.95	.5	42.55	.8	34.72			
6.5	153.8		76.92		.3	54.64	.6	42.37	.9	34.60			
7	142.9	13	.1	76.34	.4	54.35	.7	42.19	29	.1	34.48		
7.5	133.3		.2	75.76	.5	54.05	.8	42.02		.1	34.36		
8	125.0		.3	75.19	.6	53.76	.9	41.84		.2	34.25		
.1	123.5		.4	74.63	.7	53.48	24	.1	41.67	.3	34.13		
.2	122.0		.5	74.07	.8	53.19		.2	41.49	.4	34.01		
.3	120.5		.6	73.53	.9	52.91		.3	41.32	.5	33.90		
.4	119.0		.7	72.99	19	.1	52.63		.4	41.15	.6	33.78	
.5	117.6		.8	72.46		.2	52.36		.5	40.98	.7	33.67	
.6	116.3		.9	71.94		.3	52.08		.6	40.82	.8	33.56	
.7	114.9	14	.1	71.43		.4	51.81		.7	40.65	.9	33.44	
.8	113.6		.2	70.92		.5	51.55		.8	40.49	30	.1	33.33
.9	112.4		.3	70.42		.6	51.28		.9	40.32		.2	33.22
9	111.1		.4	69.93		.7	51.02			40.16		.3	33.11
.1	109.9		.5	69.44		.8	50.76		25	40.00		.4	33.00
.2	108.7		.6	68.97		.9	50.51			39.84		.5	32.89
.3	107.5		.7	68.49			50.25			39.68		.6	32.79
.4	106.4		.8	68.03	20		50.00			39.53		.7	32.68
.5	105.3		.9	67.57		.1	49.75			39.37		.8	32.57
.6	104.2			67.11		.2	49.50			39.22		.9	32.47
.7	103.1	15	.1	66.67		.3	49.26			39.06			32.36
.8	102.0		.2	66.23		.4	49.02			38.91	31	.1	32.26
.9	101.0		.3	65.79		.5	48.78			38.76		.2	32.16
10	100.0		.4	65.36		.6	48.54			38.61		.3	32.05
.1	99.01		.5	64.94		.7	48.31			38.46		.4	31.95
.2	98.04		.6	64.52		.8	48.08			38.31		.5	31.85
.3	97.09		.7	64.10		.9	47.85			38.17		.6	31.75
.4	96.15		.8	63.69	21		47.62			38.02		.7	31.65
.5	95.24		.9	63.29		.1	47.39			37.88		.8	31.55
.6	94.34			62.89		.2	47.17			37.74		.9	31.45
.7	93.46	16	.1	62.50		.3	46.95			37.59			31.35
.8	92.59		.2	62.11		.4	46.73			37.45	32	.1	31.25
.9	91.74		.3	61.73		.5	46.51			37.31		.2	31.15
11	90.91		.4	61.35		.6	46.30			37.17		.3	31.06
.2	89.29		.5	60.98		.7	46.08			37.04		.4	30.96
.3	88.50		.6	60.61		.8	45.87			36.90		.5	30.86
.4	87.72		.7	60.24		.9	45.66			36.77		.6	30.77
.5	86.96		.8	59.88	22		45.45			36.63		.7	30.67
.6	86.21		.9	59.52		.1	45.25			36.50		.8	30.58
.7	85.47	17	.1	59.17		.2	45.05			36.36		.9	30.49
.8	84.75		.2	58.82		.3	44.84			36.23			30.40
.9	84.03		.3	58.48		.4	44.64			36.10	33	.1	30.30
12	83.33		.4	58.14		.5	44.44			35.97		.2	30.21
.1	82.64		.5	57.80		.6	44.25			35.84		.3	30.12
.2	81.97		.6	57.47		.7	44.05			35.71		.4	30.03
			.7	57.14		.8	43.86			35.59		.5	29.94

{180}

TABLE FOR NUMBERING COTTON YARN-Cont'd.

120 Yds. Weigh Grains	No. of Yarn	120 Yds. Weigh Grains	No. of Yarn	120 Yds. Weigh Grains	No. of Yards	120 Yds. Weigh Grains	No. of Yards	120 Yds. Weigh Grains	No. of Yarn
33		39		44		50		56	
.5	29.85	.2	25.51	.9	22.27	.6	19.76	.3	17.76
.6	29.76	.3	25.45		22.22	.7	19.72	.4	17.73
.7	29.67	.4	25.38	.1	22.17	.8	19.69	.5	17.70
.8	29.59	.5	25.32	.2	22.12	.9	19.65	.6	17.67
.9	29.50	.6	25.25	.3	22.08		19.61	.7	17.64
	29.41	.7	25.19	.4	22.03	.1	19.57	.8	17.61
34		.8	25.13	.5	21.98	.2	19.53	.9	17.57
.1	29.33	.9	25.06	.6	21.93	.3	19.49		17.54
.2	29.24		25.00	.7	21.88	.4	19.46	.1	17.51
.3	29.15	40		.8	21.83	.5	19.42	.2	17.48
.4	29.07	.1	24.94	.9	21.79	.6	19.38	.3	17.45
.5	28.99	.2	24.88		21.74	.7	19.34	.4	17.42
.6	28.90	.3	24.81	46		.8	19.31	.5	17.39
.7	28.82	.4	24.75	.1	21.69	.9	19.27	.6	17.36
.8	28.74	.5	24.69	.2	21.65		19.23	.7	17.33
.9	28.65	.6	24.63	.3	21.60	.1	19.19	.8	17.30
35		.7	24.57	.4	21.55	.2	19.16	.9	17.27
.1	28.49	.8	24.51	.5	21.51	.3	19.12		17.24
.2	28.41	.9	24.45	.6	21.46	.4	19.08	.1	17.21
.3	28.33	41		.7	21.41	.5	19.05	.2	17.18
.4	28.25	.1	24.39	.8	21.37	.6	19.01	.3	17.15
.5	28.17	.2	24.33	.9	21.32	.7	18.98	.4	17.12
.6	28.09	.3	24.27		21.28	.8	18.94	.5	17.09
.7	28.01	.4	24.21	47		.9	18.90	.6	17.06
.8	27.93	.5	24.15	.1	21.23		18.87	.7	17.04
.9	27.86	.6	24.10	.2	21.19	.1	18.83	.8	17.01
36		.7	24.04	.3	21.14	.2	18.80	.9	16.98
.1	27.78	.8	23.98	.4	21.10	.3	18.76		16.95
.2	27.70	.9	23.92	.5	21.05	.4	18.73	.1	16.92
.3	27.62		23.87	.6	21.01	.5	18.69	.2	16.89
.4	27.55	42		.7	20.96	.6	18.66	.3	16.86
.5	27.47	.1	23.81	.8	20.92	.7	18.62	.4	16.84
.6	27.40	.2	23.75	.9	20.88	.8	18.59	.5	16.81
.7	27.32	.3	23.70		20.83	.9	18.55	.6	16.78
.8	27.25	.4	23.64	48			18.52	.7	16.75
.9	27.17	.5	23.58	.1	20.79	.1	18.48	.8	16.72
	27.10	.6	23.53	.2	20.75	.2	18.45	.9	16.69
37		.7	23.47	.3	20.70	.3	18.42		16.67
.1	27.03	.8	23.42	.4	20.66	.4	18.38	.1	16.64
.2	26.95	.9	23.36	.5	20.62	.5	18.35	.2	16.61
.3	26.88		23.31	.6	20.57	.6	18.32	.3	16.58
.4	26.81	43		.7	20.53	.7	18.28	.4	16.56
.5	26.74	.1	23.25	.8	20.49	.8	18.25	.5	16.53
.6	26.67	.2	23.20	.9	20.45	.9	18.21	.6	16.50
.7	26.60	.3	23.15		20.41		18.18	.7	16.47
.8	26.53	.4	23.09	49		.1	18.15	.8	16.45
.9	26.46	.5	23.04	.1	20.37	.2	18.12	.9	16.42
	26.39	.6	22.99	.2	20.33	.3	18.08		16.39
38		.7	22.94	.3	20.28	.4	18.05	.1	16.37
.1	26.32	.8	22.88	.4	20.24	.5	18.02	.2	16.34
.2	26.25	.9	22.83	.5	20.20	.6	17.99	.3	16.31
.3	26.18		22.78	.6	20.16	.7	17.95	.4	16.29
.4	26.11	44		.7	20.12	.8	17.92	.5	16.26
.5	26.04	.1	22.73	.8	20.08	.9	17.89	.6	16.23
.6	25.97	.2	22.68	.9	20.04		17.86	.7	16.21
.7	25.91	.3	22.62		20.00	.1	17.83	.8	16.19
.8	25.84	.4	22.57	50		.2	17.80	.9	16.16
.9	25.77	.5	22.52	.1	19.96	.3	17.77		
	25.71	.6	22.47	.2	19.92	.4	17.74		
39		.7	22.42	.3	19.88	.5	17.71		
.1	25.64	.8	22.37	.4	19.84	.6	17.68		
	25.58	.9	22.32	.5	19.80	.7	17.65		

{181}

TABLE FOR NUMBERING COTTON YARN-Cont'd.

120 Yds. Weigh Grains	No. of Yarn	120 Yds. Weigh Grains	No. of Yarn	120 Yds. Weigh Grains	No. of Yarn	120 Yds. Weigh Grains	No. of Yarn	120 Yds. Weigh Grains	No. of Yarn
		67		73		79		84	
62	16.13	.7	14.77	.4	13.62	.1	12.64	.8	11.79
.1	16.10	.8	14.75	.5	13.61	.2	12.63	.9	11.78
.2	16.08	.9	14.73	.6	13.59	.3	12.61	85	11.76
.3	16.05		14.71	.7	13.57	.4	12.59	.1	11.75
.4	16.03	68	14.68	.8	13.55	.5	12.58	.2	11.74
.5	16.00	.1	14.66	.9	13.53	.6	12.56	.3	11.72
.6	15.97	.2	14.64	74	13.51	.7	12.55	.4	11.71
.7	15.95	.3	14.62	.1	13.50	.8	12.53	.5	11.70
.8	15.92	.4	14.60	.2	13.48	.9	12.52	.6	11.68
.9	15.90	.5	14.58	.3	13.46	80	12.50	.7	11.67
63	15.87	.6	14.56	.4	13.44	.1	12.48	.8	11.66
.1	15.85	.7	14.53	.5	13.42	.2	12.47	.9	11.64
.2	15.83	.8	14.51	.6	13.40	.3	12.45	86	11.63
.3	15.80	.9	14.49	.7	13.39	.4	12.44	.1	11.61
.4	15.77	69	14.47	.8	13.37	.5	12.42	.2	11.60
.5	15.75	.1	14.45	.9	13.35	.6	12.41	.3	11.59
.6	15.72	.2	14.43	75	13.33	.7	12.39	.4	11.57
.7	15.70	.3	14.41	.1	13.32	.8	12.38	.5	11.56
.8	15.67	.4	14.39	.2	13.30	.9	12.36	.6	11.55
.9	15.65	.5	14.37	.3	13.28	81	12.35	.7	11.53
64	15.62	.6	14.35	.4	13.26	.1	12.33	.8	11.52
.1	15.60	.7	14.33	.5	13.25	.2	12.32	.9	11.51
.2	15.58	.8	14.31	.6	13.23	.3	12.30	87	11.49
.3	15.55	.9	14.29	.7	13.21	.4	12.29	.1	11.48
.4	15.53	70	14.27	.8	13.19	.5	12.27	.2	11.47
.5	15.50	.1	14.25	.9	13.18	.6	12.25	.3	11.45
.6	15.48	.2	14.22	76	13.16	.7	12.24	.4	11.44
.7	15.46	.3	14.20	.1	13.14	.8	12.22	.5	11.43
.8	15.43	.4	14.18	.2	13.12	.9	12.21	.6	11.42
.9	15.41	.5	14.16	.3	13.11	82	12.20	.7	11.40
65	15.38	.6	14.14	.4	13.09	.1	12.18	.8	11.39
.1	15.36	.7	14.12	.5	13.07	.2	12.17	.9	11.38
.2	15.34	.8	14.10	.6	13.05	.3	12.15	88	11.36
.3	15.31	.9	14.08	.7	13.04	.4	12.14	.1	11.35
.4	15.29	71	14.06	.8	13.02	.5	12.12	.2	11.34
.5	15.27	.1	14.04	.9	13.00	.6	12.11	.3	11.33
.6	15.24	.2	14.03	77	12.99	.7	12.09	.4	11.31
.7	15.22	.3	14.01	.1	12.97	.8	12.08	.5	11.30
.8	15.20	.4	13.99	.2	12.95	.9	12.06	.6	11.29
.9	15.17	.5	13.97	.3	12.94	83	12.05	.7	11.27
66	15.15	.6	13.95	.4	12.92	.1	12.03	.8	11.26
.1	15.13	.7	13.93	.5	12.90	.2	12.02	.9	11.25
.2	15.11	.8	13.91	.6	12.89	.3	12.00	89	11.24
.3	15.08	.9	13.89	.7	12.87	.4	11.99	.1	11.22
.4	15.06	72	13.87	.8	12.85	.5	11.98	.2	11.21
.5	15.04	.1	13.85	.9	12.84	.6	11.96	.3	11.20
.6	15.02	.2	13.83	78	12.82	.7	11.95	.4	11.19
.7	14.99	.3	13.81	.1	12.80	.8	11.93	.5	11.17
.8	14.97	.4	13.79	.2	12.79	.9	11.92	.6	11.16
.9	14.95	.5	13.77	.3	12.77	84	11.90	.7	11.15
67	14.93	.6	13.75	.4	12.76	.1	11.89	.8	11.14
.1	14.90	.7	13.74	.5	12.74	.2	11.88	.9	11.12
.2	14.88	.8	13.72	.6	12.72	.3	11.86	90	11.11
.3	14.86	.9	13.70	.7	12.71	.4	11.85	.1	11.10
.4	14.84	73	13.68	.8	12.69	.5	11.83	.2	11.09
.5	14.81	.1	13.66	.9	12.67	.6	11.82	.3	11.07
.6	14.79	.2	13.64	79	12.66	.7	11.81	.4	11.06

{182}

TABLE FOR NUMBERING COTTON YARN-Cont'd.

120 Yds. Weigh Grains	No. of Yarn	120 Yds. Weigh Grains	No. of Yarn	120 Yds. Weigh Grains	No. of Yarn	120 Yds. Weigh Grains	No. of Yarn	120 Yds. Weigh Grains	No. of Yarn
90	.5	11.05	2	10.40	9	9.81	.6	9.29	.6
	.6	11.04	3	10.38	9	9.80	.7	9.29	.8
	.7	11.03	4	10.37	1	9.79	.8	9.28	118
	.8	11.01	5	10.36	2	9.78	.9	9.27	.2
	.9	11.00	6	10.35	3	9.78	1	9.26	.4
91	.1	10.99	7	10.34	4	9.77	2	9.25	.6
	.2	10.98	8	10.33	5	9.76	3	9.24	.8
	.3	10.96	9	10.32	6	9.75	4	9.23	119
	.4	10.95	1	10.31	7	9.74	5	9.22	.2
	.5	10.93	2	10.30	8	9.73	6	9.21	.4
	.6	10.92	3	10.28	9	9.72	7	9.20	.6
	.7	10.91	4	10.27	1	9.71	8	9.19	.8
	.8	10.89	5	10.26	2	9.69	9	9.18	120
	.9	10.88	6	10.25	3	9.68	1	9.17	.2
92	.1	10.87	7	10.24	4	9.67	2	9.16	.4
	.2	10.86	8	10.22	5	9.66	3	9.14	.6
	.3	10.85	9	10.21	6	9.65	4	9.12	.8
	.4	10.83	1	10.20	7	9.64	5	9.11	121
	.5	10.82	2	10.19	8	9.63	6	9.09	.2
	.6	10.81	3	10.18	9	9.62	7	9.07	.4
	.7	10.80	4	10.17	1	9.62	8	9.06	.6
	.8	10.79	5	10.16	2	9.61	9	9.04	.8
	.9	10.78	6	10.15	3	9.60	1	9.03	122
93	.1	10.76	7	10.14	4	9.59	2	9.01	.2
	.2	10.75	8	10.13	5	9.58	3	8.99	.4
	.3	10.74	9	10.12	6	9.57	4	8.98	.6
	.4	10.73	1	10.11	7	9.56	5	8.96	.8
	.5	10.72	2	10.10	8	9.55	6	8.94	123
	.6	10.71	3	10.09	9	9.54	7	8.93	.2
	.7	10.70	4	10.08	1	9.53	8	8.91	.4
	.8	10.68	5	10.07	2	9.52	9	8.90	.6
	.9	10.67	6	10.06	3	9.51	1	8.88	.8
94	.1	10.66	7	10.05	4	9.51	2	8.87	124
	.2	10.65	8	10.04	5	9.50	3	8.85	.2
	.3	10.64	9	10.03	6	9.49	4	8.83	.4
	.4	10.63	1	10.02	7	9.48	5	8.82	.6
	.5	10.62	2	10.01	8	9.47	6	8.80	.8
	.6	10.60	3	10.00	9	9.46	7	8.79	125
	.7	10.59	4	9.99	1	9.45	8	8.77	.2
	.8	10.58	5	9.98	2	9.44	9	8.76	.4
	.9	10.57	6	9.98	3	9.43	1	8.74	.6
95	.1	10.56	7	9.96	4	9.43	2	8.73	.8
	.2	10.55	8	9.95	5	9.42	3	8.71	126
	.3	10.54	9	9.94	6	9.41	4	8.70	.2
	.4	10.53	1	9.93	7	9.40	5	8.68	.4
	.5	10.52	2	9.92	8	9.39	6	8.67	.6
	.6	10.50	3	9.91	9	9.38	7	8.65	.8
	.7	10.49	4	9.90	1	9.37	8	8.64	127
	.8	10.48	5	9.89	2	9.36	9	8.62	.2
	.9	10.47	6	9.88	3	9.35	1	8.61	.4
	.1	10.46	7	9.87	4	9.35	2	8.59	.6
	.2	10.45	8	9.86	5	9.34	3	8.58	.8
	.3	10.44	9	9.85	6	9.33	4	8.56	128
	.4	10.43	1	9.84	7	9.32	5	8.55	.2
	.5	10.42	2	9.83	8	9.31	6	8.53	.4
96	.6	10.41	3	9.82	9	9.30	7	8.52	.6
	.7		4				8		.8
	.8		5				9		129
	.9		6				1		.2
	1		7				2		.4
	2		8				3		.6
	3		9				4		.8
	4		1				5		130
	5		2				6		.2
	6		3				7		.4
	7		4				8		.6
	8		5				9		.8
	9		6				1		131
	1		7				2		.2
	2		8				3		.4
	3		9				4		.6
	4		1				5		.8
	5		2				6		132
	6		3				7		.2
	7		4				8		.4
	8		5				9		.6
	9		6				1		.8
	1		7				2		133
	2		8				3		.2
	3		9				4		.4
	4		1				5		.6
	5		2				6		.8
	6		3				7		134
	7		4				8		.2
	8		5				9		.4
	9		6				1		.6
	1		7				2		.8
	2		8				3		135
	3		9				4		.2
	4		1				5		.4
	5		2				6		.6
	6		3				7		.8
	7		4				8		136
	8		5				9		.2
	9		6				1		.4
	1		7				2		.6
	2		8				3		.8
	3		9				4		137
	4		1				5		.2
	5		2				6		.4
	6		3				7		.6
	7		4				8		.8
	8		5				9		138
	9		6				1		.2
	1		7				2		.4
	2		8				3		.6
	3		9				4		.8
	4		1				5		139
	5		2				6		.2
	6		3				7		.4
	7		4				8		.6
	8		5				9		.8
	9		6				1		140
	1		7				2		.2
	2		8				3		.4
	3		9				4		.6
	4		1				5		.8
	5		2				6		141
	6		3				7		.2
	7		4				8		.4
	8		5				9		.6
	9		6				1		.8
	1		7				2		142
	2		8				3		.2
	3		9				4		.4
	4		1				5		.6
	5		2				6		.8
	6		3				7		143
	7		4				8		.2
	8		5				9		.4
	9		6				1		.6
	1		7				2		.8
	2		8				3		144
	3		9				4		.2
	4		1				5		.4
	5		2				6		.6
	6		3				7		.8
	7		4				8		145
	8		5				9		.2
	9		6				1		.4
	1		7				2		.6
	2		8				3		.8
	3		9				4		146
	4		1				5		.2
	5		2				6		.4
	6		3				7		.6
	7		4				8		.8
	8		5				9		147
	9		6				1		.2
	1		7				2		.4
	2		8				3		.6
	3		9				4		.8
	4		1				5		148
	5		2				6		.2
	6		3				7		.4
	7		4				8		.6
	8		5				9		.8
	9		6				1		149
	1		7				2		.2
	2		8				3		.4
	3		9				4		.6
	4		1				5		.8
	5		2				6		150
	6		3				7		.2
	7		4				8		.4
	8		5				9		.6
	9		6				1		.8
	1		7				2		151
	2		8				3		.2
	3		9				4		.4
	4		1				5		.6
	5		2				6		.8
	6		3				7		152
	7		4				8		.2
	8		5				9		.4
	9		6				1		.6
	1		7				2		.8
	2		8				3		153
	3		9				4		.2
	4		1				5		.4
	5		2				6		.6
	6		3				7		.8
	7		4				8		154
	8		5				9		.2
	9		6				1		.4
	1		7				2		.6
	2		8				3		.8
	3		9				4		155
	4		1				5		.2
	5		2				6		.4
	6		3				7		.6
	7		4				8		.8
	8		5				9		156
	9		6				1		.2
	1		7				2		.4
	2		8				3		.6
	3		9				4		.8
	4		1				5		157
	5		2				6		.2
	6		3				7		.4
	7		4						

120 Yds. Weigh Grains	No. of Yarn	120 Yds. Weigh Grains	No. of Yarn	120 Yds. Weigh Grains	No. of Yarn	120 Yds. Weigh Grains	No. of Yarn	120 Yds. Weigh Grains	No. of Yarn
140	7.14	168	5.95	222	4.50	306	3.27	470	2.13
.5	7.12	.5	5.93	223	4.48	308	3.25	475	2.11
141	7.09	169	5.92	224	4.46	310	3.23	480	2.08
.5	7.07	.5	5.90	225	4.44	312	3.21	485	2.06
142	7.04	170	5.88	226	4.42	314	3.18	490	2.04
.5	7.02	171	5.85	227	4.41	316	3.17	495	2.02
143	6.99	172	5.81	228	4.39	318	3.14	500	2.00
.5	6.97	173	5.78	229	4.37	320	3.12	505	1.98
144	6.94	174	5.75	230	4.35	322	3.11	510	1.96
.5	6.92	175	5.71	231	4.33	324	3.09	515	1.94
145	6.90	176	5.68	232	4.31	326	3.07	520	1.92
.5	6.87	177	5.65	233	4.29	328	3.05	525	1.90
146	6.85	178	5.62	234	4.27	330	3.03	530	1.89
.5	6.83	179	5.59	235	4.26	332	3.01	535	1.87
147	6.80	180	5.56	236	4.24	334	2.99	540	1.85
.5	6.78	181	5.52	237	4.22	336	2.98	545	1.83
148	6.76	182	5.49	238	4.20	338	2.96	550	1.82
.5	6.73	183	5.46	239	4.18	340	2.94	555	1.80
149	6.71	184	5.43	240	4.17	342	2.92	560	1.79
.5	6.69	185	5.41	241	4.15	344	2.91	565	1.77
150	6.67	186	5.38	242	4.13	346	2.89	570	1.75
.5	6.64	187	5.35	243	4.12	348	2.87	575	1.74
151	6.62	188	5.32	244	4.10	350	2.86	580	1.72
.5	6.60	189	5.29	245	4.08	352	2.84	585	1.71
152	6.58	190	5.26	246	4.07	354	2.82	590	1.69
.5	6.56	191	5.24	247	4.05	356	2.81	595	1.68
153	6.54	192	5.21	248	4.03	358	2.79	600	1.67
.5	6.51	193	5.18	249	4.02	360	2.78	610	1.64
154	6.49	194	5.15	250	4.00	362	2.76	620	1.61
.5	6.47	195	5.13	252	3.97	364	2.75	630	1.59
155	6.45	196	5.10	254	3.94	366	2.73	640	1.56
.5	6.43	197	5.08	256	3.91	368	2.72	650	1.54
156	6.41	198	5.05	258	3.88	370	2.70	660	1.52
.5	6.39	199	5.03	260	3.85	372	2.69	670	1.49
157	6.37	200	5.00	262	3.82	374	2.67	680	1.47
.5	6.35	201	4.98	264	3.79	376	2.66	690	1.45
158	6.33	202	4.95	266	3.76	378	2.65	700	1.43
.5	6.31	203	4.93	268	3.73	380	2.63	710	1.41
159	6.29	204	4.90	270	3.70	382	2.62	720	1.39
.5	6.27	205	4.88	272	3.68	385	2.60	730	1.37
160	6.25	206	4.85	274	3.65	390	2.56	740	1.35
.5	6.23	207	4.83	276	3.62	395	2.53	750	1.33
161	6.21	208	4.81	278	3.60	400	2.50	760	1.32
.5	6.19	209	4.78	280	3.57	405	2.47	770	1.30
162	6.17	210	4.76	282	3.55	410	2.44	780	1.28
.5	6.15	211	4.74	284	3.52	415	2.41	790	1.27
163	6.13	212	4.72	286	3.50	420	2.38	800	1.25
.5	6.12	213	4.69	288	3.47	425	2.35	820	1.22
164	6.10	214	4.67	290	3.45	430	2.33	840	1.19
.5	6.08	215	4.65	292	3.42	435	2.30	860	1.16
165	6.06	216	4.63	294	3.40	440	2.27	880	1.14
.5	6.04	217	4.61	296	3.38	445	2.25	900	1.11
166	6.02	218	4.59	298	3.36	450	2.22	925	1.08
.5	6.01	219	4.57	300	3.33	455	2.20	950	1.05
167	5.99	220	4.55	302	3.31	460	2.17	975	1.03
.5	5.97	221	4.52	304	3.29	465	2.15	1000	1.00

{184}

DRAPER TABLES OF BREAKING WEIGHTS OF AMERICAN YARNS SPUN FROM AMERICAN COTTON.

AVERAGED FROM SAMPLE SKEIN TESTS FROM SEVERAL HUNDRED AMERICAN MILLS.

Weight in Grains of 120 Yards	No. of Yarn	Breaking Weight of Warp Yarn		Breaking Weight of		Weight in Grains of 120 Yards	No. of Yarn	Breaking Weight of	
		OLD	NEW	Combed Warp NEW	Soft Twist Yarn NEW			Warp Yarn OLD	Combed Warp NEW
1000	1					19.6	51	36.6	47-
500	2					19.2	52	36.1	46
333.3	3	530	634+	863-	620+	18.9	53	35.5	45+
250	4	410	470-	646	462	18.5	54	34.9	44-
200	5	330	381	516	367	18.2	55	34.4	43
166.7	6	275	318-	429+	304-	17.9	56	33.8	42+
142.9	7	237.6	272+	367+	258+	17.5	57	33.4	42
125	8	209	238+	321	224+	17.2	58	32.8	41-
111.1	9	186.5	212+	285-	198+	17	59	32.3	40+
100	10	168.7	191	256	177	16.7	60	31.7	39-
90.9	11	154.1	174-	232+	160-	16.4	61	31.3	39
83.3	12	142	159+	213-	145+	16.1	62	30.8	38-
76.9	13	131.5	147+	196	133+	15.9	63	30.4	37+
71.4	14	122.8	137-	182-	123-	15.6	64	30	37-
66.7	15	115.1	128-	169+	114-	15.4	65	29.6	36
62.5	16	108.4	120-	158-	106-	15.2	66	29.2	35+
58.8	17	102.5	113-	149-	99-	14.9	67	28.8	35-
55.6	18	97.3	107-	140+	93-	14.7	68	28.5	34+
52.6	19	92.6	101	133-	87-	14.5	69	28.2	34-
50	20	88.3	96	126	82	14.3	70	27.8	33+
47.6	21	83.8	91+	120-	77+	14.1	71	27.4	33-
45.5	22	79.7	87+	114+	73-	13.9	72	27.1	32+
43.5	23	75.9	84-	109-	70-	13.7	73	26.8	32-
41.7	24	72.4	80+	104+	66+	13.5	74	26.5	31+
40	25	69.2	77	100	63	13.3	75	26.2	31-
38.5	26	66.3	74+	96	60+	13.2	76	25.8	30+
37	27	63.6	71+	92+	57+	13	77	25.5	30-
35.7	28	61.3	69-	89-	55-	12.8	78	25.3	29+
34.5	29	59.2	67-	86-	53-	12.7	79	24.9	29-
33.3	30	57.3	64+	83-	50+	12.5	80	24.6	28+
32.3	31	55.6	62	80	48	12.4	81	24.3	28-
31.3	32	54	60+	77+	46+	12.2	82	24	28
30.3	33	52.6	59-	75-	45-	12.1	83	23.7	27+
29.4	34	51.2	57-	72-	43-	11.9	84	23.4	27-
28.6	35	50	55+	70	41+	11.8	85	23.2	27
27.8	36	48.7	54-	68-	40-	11.6	86	22.8	26+
27	37	47.6	52+	66+	38+	11.5	87	22.6	26-
26.3	38	46.5	51	64	37	11.4	88	22.4	26
25.6	39	45.5	50-	63-	36-	11.2	89	22.2	25+
25	40	44.6	48+	61	34+	11.1	90	22	25-
24.4	41	43.8	47-	59+	33-	11	91	21.7	25
23.8	42	43	46	58-	32-	10.9	92	21.5	24+
23.3	43	42.2	45-	56+	31-	10.8	93	21.3	24-
22.7	44	41.4	44+	55-	30-	10.6	94	21.2	24
22.2	45	40.7	43-	54-	29-	10.5	95	21	23+
21.7	46	40	42-	53-	28-	10.4	96	20.7	23-
21.3	47	39.3	41+	51+	27+	10.3	97	20.5	23
20.8	48	38.6	41-	50-	27-	10.2	98	20.4	23-
20.4	49	37.9	40-	49-	26-	10.1	99	20.2	22+
20	50	37.3	39	48	25	10	100	20	22-

{185}

TRAVELLER TABLE FOR RING SPINNING FRAME.

No. of Yarn	Warp Yarn				Filling Yarn			
	Revs. of Spindles	Dia. of Ring	No. of Traveller	Weight of 10 Travellers in Grains	Revs. of Spindles	Dia. of Ring	No. of Traveller	Weight of 10 Travellers in Grains
4	4950		14	39	4000		16	44
6	5900	2¼	12	33	4800		13	36
8	6650		9	23	5450		10	26
10	7250		8	20	5950		8	20
11	7500		7	18	6150		7	18
12	7750	2½	6	16	6350		6	16
13	7950		6	16	6500		5	14
14	8150		5	14	6700		4	13
15	8300		4	13	6850	1½	3	12
16	8450		3	12	6950	1½	2	11
17	8600		2	11	7100	1½	1	10
18	8750		1	10	7200		1-0	9
19	8850		1-0	9	7300		3-0	8
20	8950	2	2-0	8½	7400		5-0	7
21	9050		3-0	8	7500		5-0	7
22	9100		4-0	7½	7600		6-0	6½
23	9150		5-0	7	7700		6-0	6½
24	9200		6-0	6½	7800		7-0	6
28	9500	1½	7-0	6	7900		8-0	5½
32	9500		8-0	5½	7900		9-0	5
34	9600		9-0	5	7900	1¾	10-0	4½
36	9700	1¾	10-0	4½	7900		11-0	4
38	9800		11-0	4	7900		12-0	3¾
40	9700		12-0	3¾	7900		13-0	3½
45	9700		13-0	3¾	7900		14-0	3¾
50	9700	1½	14-0	3¾	7900		15-0	3
55	9600		14-0	3¾	7900		15-0	3
60	9600		15-0	3	7900		16-0	2¾
65	9600		15-0	3	7800		16-0	2¾
70	9600		16-0	2¾	7800	1¾	17-0	2½
75	9500		16-0	2¾	7800		17-0	2½
80	9500		17-0	2½	7700		18-0	2¼
85	9100	1¾	17-0	2½	7600		18-0	2¼
90	9100		18-0	2¼	7400		19-0	2
95	9000		19-0	2	7400		20-0	1¾
100	8700		20-0	1¾	7200		21-0	1½
110	8500		21-0	1½	6900		22-0	1¼

The speed, kind of cotton, etc., affect the weight of traveller, and consequently it is impossible to make up a table to cover all conditions, but the sizes given above will serve as a basis to select from. Lighter travellers should be used for higher speeds and vice versa. Each 1,000 revolutions of spindle makes a difference of one or two numbers in travellers.

{186}

SPOOLERS.

The following tables of dimensions and productions are given as information:

DIMENSIONS OF SPOOLERS.												
Gauge	3½	3¼	4	4¼	4½	4¾	5	5¼	5½	5¾	6	6½
Dia. Head of Spool	2¾	3	3¼	3½	3¾	4	4¼	4½	4¾	5	5¼	5½
No. of Spindles	Lengths in Feet and Inches											
60	10-3	10-11	11-6	12-1	12-8	13-4	13-11	14-6	15-1	15-9	16-4	17-6
80	13-2	14-0	14-10	15-8	16-5	17-3	18-1	18-11	19-8	20-6	21-4	22-11
100	16-1	17-2	18-2	19-2	20-2	21-3	22-3	23-3	24-3	25-4		
120	.. .	20-3	21-6	22-9	23-11	25-2	26-5	27-8				
150	28-0	29-7							

Width, including bobbin boxes, four feet.
 Weight, from thirty to forty pounds per spindle complete.

PRODUCTIONS.

Dimensions of Spool		No. of Yarn	Revs. per Minute of the			No. of Spinning Spindles to 1 Spooler Spindle. Running at 825 Revs. per Minute
Length Between Heads	Dia. of Heads		Cylinder, 200 Spindle, 750	Cylinder, 220 Spindle, 825	Cylinder, 240 Spindle, 900	
Pounds per Spindle per Week						
6	5	8	64.3	70.7	77.1	12
		10	51.4	56.6	61.7	
		12	42.9	47.1	51.4	
		14	36.7	40.4	44.1	
		16	32.1	35.3	38.6	
		18	28.6	31.4	34.3	
		20	25.7	28.3	30.9	
		22	23.4	25.7	28.1	
		24	21.4	23.6	25.7	
		26	19.8	21.8	23.7	
5	4	28	18.4	20.2	22.0	15
		29	17.7	19.5	21.3	
		30	17.1	18.9	20.6	
		32	16.1	17.7	19.3	
		34	15.1	16.6	18.1	
		36	14.3	15.7	17.1	
		38	13.5	14.9	16.2	
		40	12.9	14.1	15.4	
		44	11.7	12.9	14.0	
		50	10.3	11.3	12.3	
3½	3¼	60	8.6	9.4	10.3	21
		70	7.3	8.1	8.8	23
		80	6.4	7.1	7.8	25

{187}

REELS.

Reels are usually made with 50 or 60 spindles each, but can be made either longer or shorter. The common gauge is 3-1/2 in., the length of which with 50 spindles is 16 ft. 8-1/2 in. and width 3 ft. 9 in. Machines are made for 54-in., 60-in., 72-in. and 90-in. skeins, usually 54 in.

Driving pulleys are 12 in. x 2 in.

The usual speed with 54-in. swifts is 130 revs. We give below production table for 54-in. skeins.

Production per Spindle per Week of 60 Hours				
54-in. Reel—Revs. per Minute				
No. Yarn	120	130	140	150
2	192.60	208.80	225.00	241.20
4	96.30	104.40	112.20	120.30
6	64.20	69.60	75.00	80.40
8	48.00	52.20	56.10	60.30
10	38.55	41.76	45.00	48.21
12	32.10	34.80	37.50	40.17
14	27.51	29.82	32.13	34.41
16	24.09	26.10	28.14	30.12
18	21.42	23.22	25.02	26.79
20	19.26	20.88	22.50	24.12
25	15.42	16.71	18.00	19.29
30	12.84	13.92	15.00	16.05
40	9.63	10.44	11.22	12.03
50	7.71	8.34	9.00	9.63
60	6.42	6.96	7.50	8.04
70	5.49	5.97	6.42	6.87
80	4.80	5.22	5.61	6.03
90	4.26	4.65	5.01	5.34
100	3.84	4.17	4.50	4.80

50 per cent. allowance has been made in above table for doffing, etc.

{188}

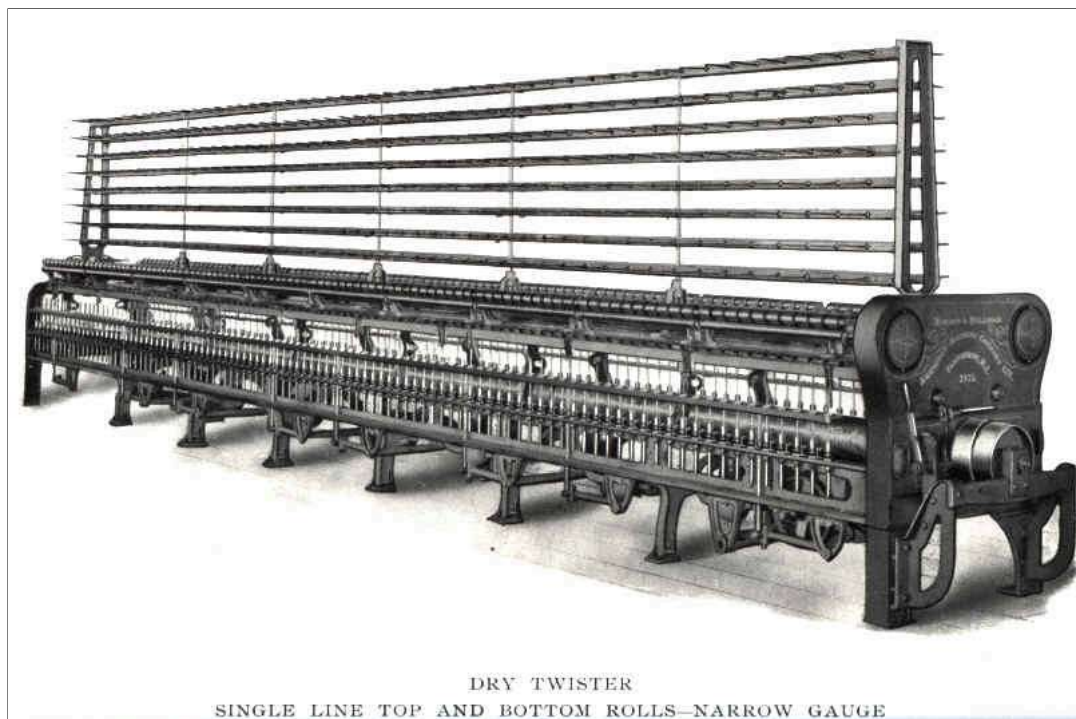

DRY TWISTER
SINGLE LINE TOP AND BOTTOM ROLLS—NARROW GAUGE
DRY TWISTER
SINGLE LINE TOP AND BOTTOM ROLLS—NARROW GAUGE

{189}

RING TWISTERS. FOR DRY OR WET TWISTING.

Our Ring Twister resembles our Spinning Frame, both in construction and design, and the descriptive matter on [pages 140](#) and [151](#) apply to this machine.

The marked success of our Spinning Frame led us to build a Twister embodying the same improvements and special features which have been so much appreciated. All parts are machined, and are interchangeable.

LOW FRAMING AND HEAVY RIGID CONSTRUCTION—The frames are built very low, are extra heavy in all their principal parts and are designed and constructed so as to stand high speeds without vibration, thus preserving the spindles, insuring light running and reducing the cost of repairs.

DRY AND WET TWISTING—We build machines for either Dry or Wet Twisting. When for wet work the bottom and top rolls are covered with brass, and brass troughs are provided for the water. The yarn is submerged by means of glass rods which are easily raised or lowered.

ARRANGEMENT OF ROLLS—Machines are built with any of the following arrangements of Rolls:

- Single Line Bottom Rolls, and Single Line Top Rolls.
- Double Line Bottom Rolls, and Single Line Top Rolls.
- Double Line Bottom Rolls, and Double Line Top Rolls.

SPINDLES—Any of the improved modern high-speed spindles are supplied as required. We do not make any Twisters with common or old style "Two Rail" spindles.

KNEE BRAKES are furnished when required.

GAUGES AND RINGS—We build machines from 2-1/2-in. gauge with 1-1/2-in. rings up to 5-1/2-in. gauge with 4-1/2-in. rings. Any desired form or style of ring will be furnished. All of these rings are made from high-grade steel of special analysis, hardened by improved methods and accurately finished.

{190}

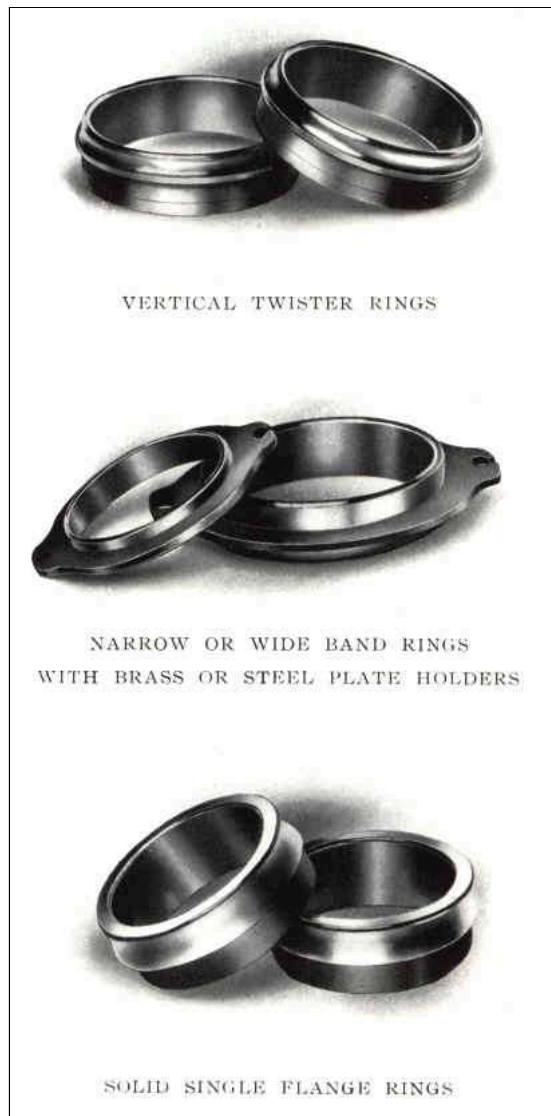

VERTICAL TWISTER RINGS

NARROW OR WIDE BAND RINGS
WITH BRASS OR STEEL PLATE HOLDERS

SOLID SINGLE FLANGE RINGS

VERTICAL TWISTER RINGS

NARROW OR WIDE BAND RINGS
WITH BRASS OR STEEL PLATE HOLDERS

SOLID SINGLE FLANGE RINGS

{191}

THE FOLLOWING HEADINGS ARE TAKEN UP IN DETAIL UNDER RING SPINNING FRAMES:

SPINDLE RAILS of box pattern to prevent springing or twisting.

LIFTING RODS specially finished to avoid sticking, and easily removed and cleaned without necessity of readjustment.

RE-LEVELLING easily taken care of by means of adjustable foot casting and jack screw on each Spring Piece.

ADJUSTABLE THREAD BOARD LIFTERS.

RING OILING BEARING ON OUTRIGGER.

SELF-LUBRICATING LOOSE PULLEY ON SLEEVE.

IMPROVED FORM OF CYLINDER HEAD.

PHOSPHOR BRONZE CYLINDER BEARINGS of self-oiling type.

GEARING, simple and enclosed in boxed end to prevent accident. All cut gears.

BUILDER of simple and effective design adjustable for Filling, Warp, Conant, Reverse Conant, or Straight Wind.

CREELS with rigid end and center supports, free from vibration.

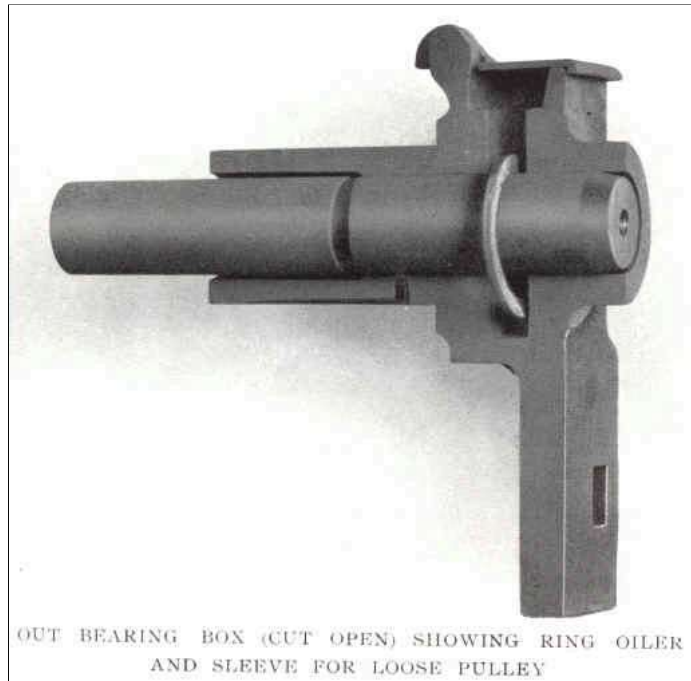

OUT BEARING BOX (CUT OPEN) SHOWING RING OILER AND SLEEVE FOR LOOSE PULLEY

{192}

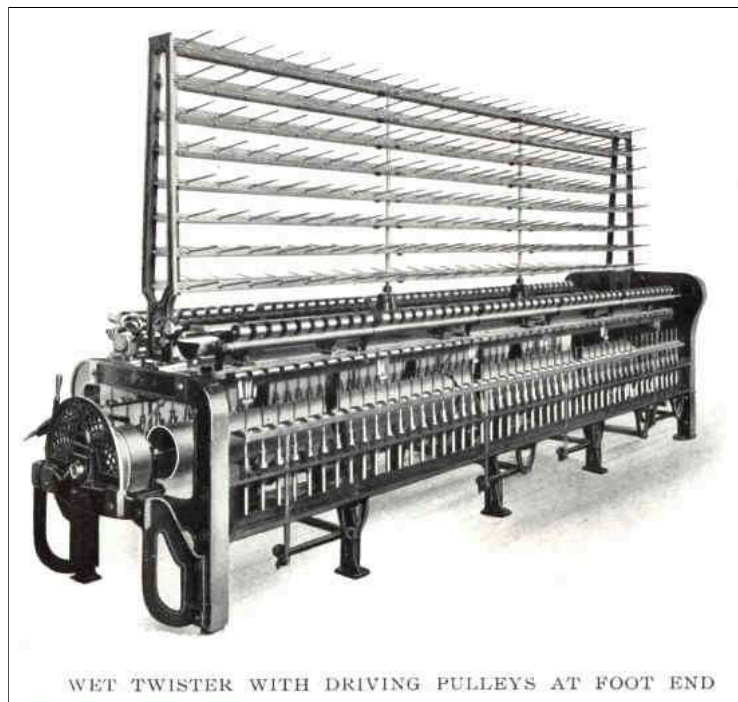

WET TWISTER, WITH DRIVING PULLEYS AT FOOT END

{193}

FLOOR SPACE OF TWISTERS.

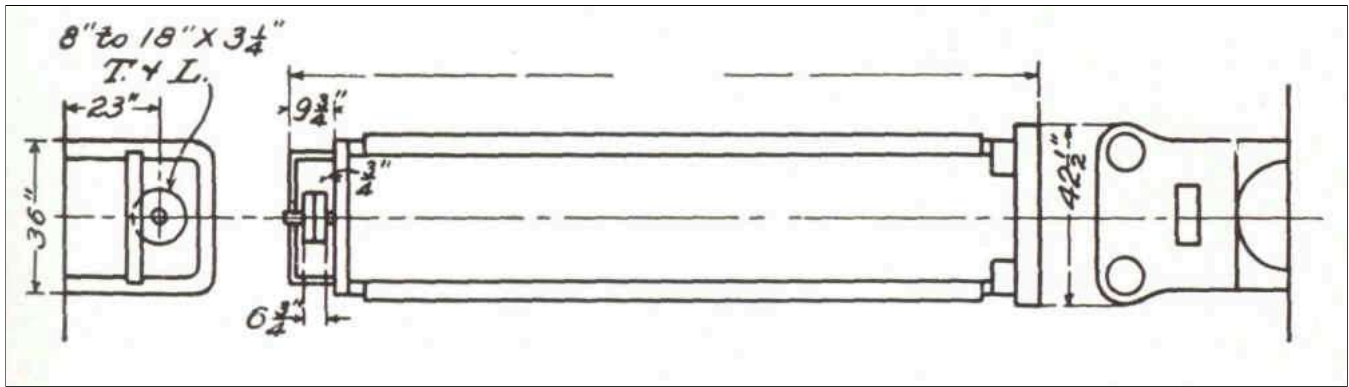

WIDTHS OF MACHINES.

- 2-1/2-in. and 2-3/4-in. Gauge = 3 ft. 1-1/8 in. over all
- 3-in. and 3-1/4-in. Gauge = 3 ft. 1-5/8 in. over all
- 3-1/2-in. and 4-in. Gauge = 3 ft. 2-5/8 in. over all
- 4-1/2-in. Gauge = 3 ft. 3-3/4 in. over all
- 5-in. Gauge = 3 ft. 4-1/4 in. over all
- 5-in. Gauge = 3 ft. 5 in. over all

To ascertain the length of Twisters with any number of spindles: Multiply one-half the number of spindles by the gauge and add 2 ft. 1 in. for head and off ends.

Although it is advantageous when possible to keep to the numbers of spindles given in the table on [page 195](#), other lengths can be built if necessary. Even rolls and boxes are preferable.

DRIVING PULLEYS are 8 in. to 18 in. dia., 3-1/4-in. face.

{194}

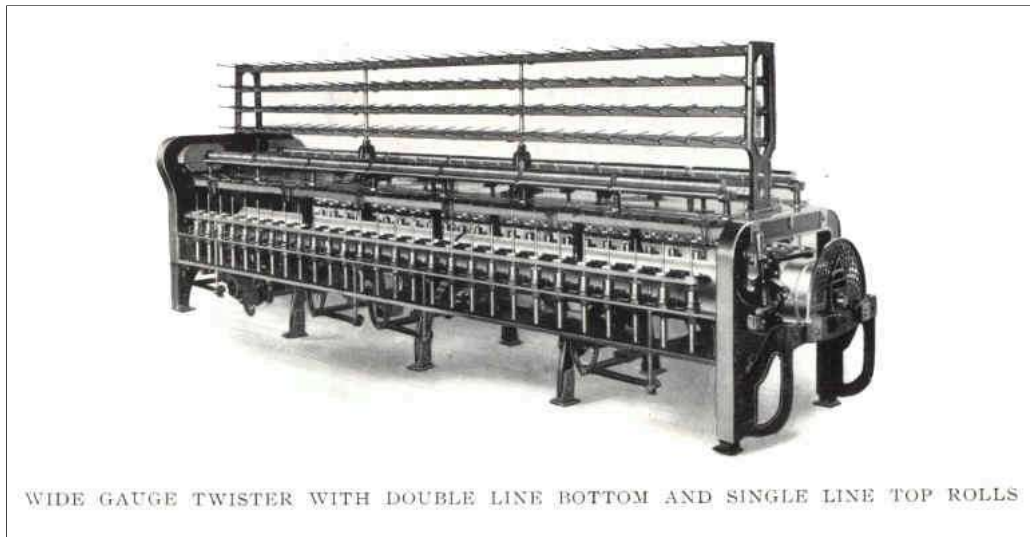

WIDE GAUGE TWISTER WITH DOUBLE LINE BOTTOM AND SINGLE LINE TOP ROLLS

{195}

LENGTHS OVER ALL OF TWISTERS.

LENGTHS OVER ALL OF TWISTERS.

Gauge	2 3/4 In.	3 In.	3 1/4 In.	3 1/2 In.	4 In.	4 1/2 In.	5 In.	5 1/2 In.
Ring	1 3/4 In.	2 In.	2 1/4 In.	2 1/2 In.	3 In.	3 1/2 In.	4 In.	4 1/2 In.
Spindles per Roll	12	10	10	8	8	6	6	6
No. of Spindles	Ft. In.	Ft. In.	Ft. In.	Ft. In.	Ft. In.	Ft. In.	Ft. In.	Ft. In.
60	13- 4	14-7	15-10
64	11-5	12-9			
72	15- 7	17-1	18- 7
80	12-1	12-11	13-9	15-5			
84	17-10	19-7	21- 4
96	13- 1	16-1	18-1	20- 1	22-1	24- 1
100	14-7	15- 7 1/2					
108	22- 4	24-7	26-10
112	18-5	20-9			
120	15-10	17-1	18- 4	24- 7	27-1	29- 7
128	20-9	23-5			
132	26-10	29-7	32- 4
140	19-7	21- 0 1/2					
144	18- 7	23-1	26-1	29- 1	32-1	
156	31- 4		
160	22-1	23- 9	25-5	28-9			
168	21- 4							
176	27-9	31-5			
180	24-7	26- 5 1/2					
192	24- 1	30-1				
200	27-1	29- 2					
216	26-10							
220	29-7	31-10 1/2					
240	29- 7	32-1						

{196}

TABLE SHOWING GAUGES, RINGS AND SPINDLE SPEEDS FOR VARIOUS NUMBERS AND PLYS

THIS TABLE FORMS A KEY TO THE PRODUCTION TABLES WHICH FOLLOW

TABLE SHOWING GAUGES, RINGS AND SPINDLE SPEEDS FOR VARIOUS NUMBERS AND PLYS
THIS TABLE FORMS A KEY TO THE PRODUCTION TABLES WHICH FOLLOW

196

6 Ply		5 Ply		4 Ply		3 Ply		2 Ply		Per Cent. Loss in Production Allowed	Gauge of Twister in In.	Diam. of Ring in In.	Rev. per Minute of Spindles	Spindle Speed Multiplied by Ring Diam.
No. of Yarn to be Twisted	No. of Twisted Yarn	No. of Yarn to be Twisted	No. of Twisted Yarn	No. of Yarn to be Twisted	No. of Twisted Yarn	No. of Yarn to be Twisted	No. of Twisted Yarn	No. of Yarn to be Twisted	No. of Twisted Yarn					
6	1.00									20	5½	4½	2,800	12,600
7	1.17	6	1.20							18				
8	1.33	7	1.40							17				
9	1.50	8	1.60	6	1.50					16				
10	1.67	9	1.80	7	1.75					16				
12	2.00	10	2.00	8	2.00	6	2.00			15	5	4	3,300	13,200
14	2.33	12	2.40	9	2.25	7	2.33			15				
15	2.50			10	2.50					14				
16	2.67	14	2.80			8	2.67			14				
18	3.00	15	3.00	12	3.00	9	3.00	6	3.00	13	4½	3½	3,800	13,300
20	3.33	16	3.20	14	3.50	10	3.33	7	3.50	13				
22	3.67	18	3.60	15	3.75					13				
24	4.00	20	4.00	16	4.00	12	4.00	8	4.00	12				
26	4.33	22	4.40	18	4.50			9	4.50	12				
28	4.67	24	4.80			14	4.67			12				
30	5.00	25	5.00	20	5.00	15	5.00	10	5.00	11	4	3	4,500	13,500
32	5.33	26	5.20	22	5.50	16	5.33			11				
34	5.67	28	5.60							11				
36	6.00	30	6.00	24	6.00	18	6.00	12	6.00	11				
38	6.33	32	6.40	26	6.50					11				
40	6.67	34	6.80			20	6.67			11				
42	7.00	35	7.00	28	7.00	21	7.00	14	7.00	10	3½	2½	5,400	13,500
44	7.33	36	7.20	30	7.50	22	7.33	15	7.50	10				
46	7.67	38	7.60							10				
48	8.00	40	8.00	32	8.00	24	8.00	16	8.00	10				

{197}

TABLE SHOWING GAUGES, RINGS AND SPINDLE SPEEDS—CONT'D.

TABLE SHOWING GAUGES, RINGS AND SPINDLE SPEEDS—CONT'D.

6 Ply		5 Ply		4 Ply		3 Ply		2 Ply		Per Cent. Loss in Production Allowed	Gauge of Twister in In.	Diam. of Ring in In.	Rev. per Minute of Spindles	Spindle Speed Multiplied by Ring Diam.
No. of Yarn to be Twisted	No. of Twisted Yarn	No. of Yarn to be Twisted	No. of Twisted Yarn	No. of Yarn to be Twisted	No. of Twisted Yarn	No. of Yarn to be Twisted	No. of Twisted Yarn	No. of Yarn to be Twisted	No. of Twisted Yarn					
50	8.33	42	8.40	34	8.50					9				
54	9.00	44	8.80			26	8.66			9				
		45	9.00	36	9.00	27	9.00	18	9.00	9				
		46	9.20			28	9.33			9				
		48	9.60	38	9.50					9				
60	10.00	50	10.00	40	10.00	30	10.00	20	10.00	9	3¼	2¼	6,000	13,500
				42	10.50	32	10.66			9				
66	11.00	55	11.00	44	11.00	33	11.00	22	11.00	8				
70	11.67			46	11.50	34	11.33			8				
		60	12.00	48	12.00	36	12.00	24	12.00	8				
				50	12.50	38	12.67	26	13.00	8				
						40	13.33			8				
		70	14.00	56	14.00	42	14.00	28	14.00	7				
						44	14.67			7				
				60	15.00	45	15.00	30	15.00	7				
						46	15.33			7				
				64	16.00	48	16.00	32	16.00	7				
				70	17.50	50	16.67	34	17.00	6	3	2	6,750	13,500
								36	18.00	6				
								38	19.00	6				
						60	20.00	40	20.00	6				
								42	21.00	5				
								44	22.00	5				
						70	23.33	46	23.00	5				
								48	24.00	5				
								50	25.00	5	3	1¼	7,200	12,600
								60	30.00	5				
								70	35.00	5				

197

{198}

TABLE SHOWING NUMBER OF POUNDS TWISTED YARN PRODUCED IN 10 HOURS-2 PLY

TABLE SHOWING NUMBER OF POUNDS TWISTED YARN PRODUCED IN 10 HOURS—2 PLY

No. of Yarn to be Twisted	Gauge of Frame	Dia. of Ring	Revs. of Spindle per Minute	Multiplier 4		Multiplier 5		Multiplier 6		No. of Yarn to be Twisted
				Rev. of 1½-In. Roll per Min.	Pounds per Spindle	Rev. of 1½-In. Roll per Min.	Pounds per Spindle	Rev. of 1½-In. Roll per Min.	Pounds per Spindle	
6	4½	3½	3800	116	3.15	93	2.52	78	2.10	6
7			3800	108	2.51	86	2.00	72	1.67	7
8			3800	101	2.07	81	1.66	67	1.38	8
9	4	3	3800	95	1.74	76	1.39	63	1.16	9
10			4500	107	1.78	85	1.42	71	1.18	10
12			4500	97	1.35	73	1.08	65	.90	12
14	3½	2½	5400	108	1.30	87	1.04	72	.87	14
15			5400	105	1.17	84	.94	70	.78	15
16			5400	101	1.07	81	.85	68	.71	16
18	3¼	2¼	5400	95	.89	76	.71	64	.60	18
20			6000	101	.86	81	.69	67	.57	20
22			6000	96	.75	77	.60	64	.50	22
24	3	2	6000	92	.66	74	.53	61	.44	24
26			6000	88	.58	71	.47	59	.39	26
28			6000	85	.53	68	.42	57	.35	28
30	2¾	1¾	6000	82	.48	66	.38	55	.32	30
32			6000	80	.43	64	.35	53	.29	32
34			6750	87	.45	69	.36	58	.30	34
36	3	2	6750	84	.41	68	.33	56	.27	36
38			6750	82	.38	66	.30	55	.25	38
40			6750	80	.35	64	.28	53	.23	40
42	2¾	1¾	6750	78	.33	62	.26	52	.22	42
44			6750	76	.31	61	.25	51	.21	44
46			6750	75	.29	60	.23	50	.19	46
48	3	2	6750	73	.27	58	.22	49	.18	48
50			7200	76	.27	61	.22	51	.18	50
60			7200	70	.21	56	.17	46	.14	60
70			7200	65	.16	52	.13	43	.11	70

Allowance has been made for doffing, waste, cleaning, etc.

{199}

TABLE SHOWING NUMBER OF POUNDS TWISTED YARN PRODUCED IN 10 HOURS-3 PLY.

No. of Yarn to be Twisted	Gauge of Frame	Dia. of Ring	Revs. of Spindle per Minute	Multiplier 4		Multiplier 5		Multiplier 6		No. of Yarn to be Twisted
				Rev. of 1½-in. Roll per Min.	Pounds per Spindle	Rev. of 1½-in. Roll per Min.	Pounds per Spindle	Rev. of 1½-in. Roll per Min.	Pounds per Spindle	
6	5	4	3300	124	4.92	99	3.94	82	3.28	6
7			3300	115	3.90	92	3.12	76	2.60	7
8			3300	107	3.23	86	2.59	71	2.15	8
9	4½	3½	3800	116	3.15	93	2.52	78	2.10	9
10			3800	110	2.70	88	2.15	74	1.80	10
12			3800	101	2.07	81	1.66	67	1.38	12
14	4	3	3800	93	1.65	75	1.32	62	1.10	14
15			4500	107	1.78	85	1.42	71	1.18	15
16			4500	103	1.61	83	1.29	69	1.08	16
18	3½	2½	4500	97	1.35	78	1.08	65	.90	18
20			4500	91	1.13	74	.92	62	.77	20
22			5400	106	1.21	85	.97	71	.81	22
24	3¼	2¼	5400	101	1.07	81	.85	68	.71	24
26			5400	97	.96	78	.76	65	.64	26
28			5400	94	.85	75	.68	63	.57	28
30	3	2	6000	101	.86	81	.69	67	.57	30
32			6000	97	.78	78	.62	65	.52	32
34			6000	95	.72	76	.57	63	.48	34
36	2¾	1¾	6000	92	.66	74	.53	61	.44	36
38			6000	89	.61	72	.49	60	.40	38
40			6000	87	.56	70	.45	58	.37	40
42	3	2	6000	85	.53	68	.42	57	.35	42
44			6000	83	.49	66	.39	55	.33	44
46			6000	81	.46	65	.37	54	.31	46
48	2¾	1¾	6000	80	.43	64	.35	53	.29	48
50			6750	88	.46	70	.37	58	.31	50
60			6750	80	.35	64	.28	53	.23	60
70			6750	74	.28	59	.23	49	.19	70

Allowance has been made for doffing, waste, cleaning, etc.

{200}

TABLE SHOWING NUMBER OF POUNDS TWISTED YARN PRODUCED IN 10 HOURS-4 PLY.

No. of Yarn to be Twisted	Gauge of Frame	Dia. of Ring	Revs. of Spindle per Minute	Multiplier 4		Multiplier 5		Multiplier 6		No. of Yarn to be Twisted
				Revs. of 1½-in. Roll per Minute	Pounds per Spindle	Revs. of 1½-in. Roll per Minute	Pounds per Spindle	Revs. of 1½-in. Roll per Minute	Pounds per Spindle	
6	5½	4½	2800	121	6.35	97	5.08	81	4.23	6
7			2800	112	5.04	90	4.03	75	3.86	7
8			3300	124	4.92	99	3.94	82	3.28	8
9	5	4	3300	117	4.12	93	3.31	78	2.75	9
10			3300	111	3.56	89	2.85	74	2.37	10
12			3800	116	3.15	93	2.52	78	2.10	12
14	4½	3½	3800	108	2.51	86	2.00	72	1.67	14
15			3800	104	2.26	83	1.81	69	1.50	15
16			3800	101	2.07	81	1.66	67	1.38	16
18	4	3	3800	96	1.74	76	1.39	63	1.16	18
20			4500	107	1.78	85	1.42	71	1.18	20
22			4500	102	1.54	81	1.23	68	1.03	22
24	3½	2½	4500	97	1.35	78	1.08	65	.90	24
26			4500	94	1.20	75	.96	62	.80	26
28			5400	108	1.30	87	1.04	72	.87	28
30	3	2	5400	105	1.17	84	.94	70	.78	30
32			5400	101	1.07	81	.85	68	.71	32
34			5400	98	.98	79	.79	66	.66	34
36	3¼	2¼	5400	95	.90	76	.72	64	.60	36
38			5400	93	.83	74	.67	62	.55	38
40			6000	101	.86	81	.69	67	.57	40
42	3	2	6000	98	.80	79	.64	65	.53	42
44			6000	95	.75	77	.60	64	.50	44
46			6000	94	.70	75	.56	63	.47	46
48	3	2	6000	92	.66	74	.53	61	.44	48
50			6000	90	.62	72	.50	60	.41	50
60			6000	82	.48	66	.38	55	.32	60
70			6750	86	.43	68	.34	57	70	

Allowance has been made for doffing, waste, cleaning, etc.

{201}

TABLE SHOWING NUMBER OF POUNDS TWISTED YARN PRODUCED IN 10 HOURS-5 PLY.

No. of Yarn to be Twisted	Gauge of Frame	Dia. of Ring	Revs. of Spindle per Minute	Multiplier 4		Multiplier 5		Multiplier 6		No. of Yarn to be Twisted
				Revs. of 1½-in. Roll per Min.	Pounds per Spindle	Revs. of 1½-in. Roll per Min.	Pounds per Spindle	Revs. of 1½-in. Roll per Min.	Pounds per Spindle	
6	5½	4½	2800	136	8.67	108	6.93	90	5.78	6
7			2800	126	6.96	100	5.56	84	4.64	7
8			2800	117	5.76	94	4.63	78	3.84	8
9	5	4	2800	111	4.83	89	3.86	74	3.22	9
10			3300	124	4.92	99	3.94	82	3.28	10
12			3300	113	3.74	90	2.99	75	2.49	12
14	4½	3½	3300	105	3.01	84	2.40	70	2.00	14
15			3800	116	3.15	93	2.52	78	2.10	15
16			3800	113	2.86	90	2.29	75	1.91	16
18	4	3	3800	106	2.40	85	1.92	71	1.60	18
20			3800	101	2.07	81	1.66	67	1.38	20
22			3800	96	1.80	77	1.44	64	1.20	22
24	3½	2½	3800	92	1.58	74	1.26	61	1.05	24
26			4500	105	1.68	84	1.34	70	1.12	26
28			4500	101	1.50	81	1.20	67	1.00	28
30	3	2	4500	97	1.35	78	1.08	65	.90	30
32			4500	94	1.23	75	.98	63	.82	32
34			4500	92	1.12	73	.90	61	.75	34
36	3¼	2¼	5400	107	1.25	85	1.00	71	.83	36
38			5400	104	1.15	83	.92	69	.77	38
40			5400	101	1.07	81	.85	68	.71	40
42	3	2	5400	99	1.00	79	.80	66	.67	42
44			5400	97	.98	77	.75	64	.62	44
46			5400	94	.87	75	.70	63	.58	46
48	3	2	5400	92	.82	74	.66	62	.55	48
50			6000	101	.86	81	.69	67	.57	50
60			6000	92	.66	74	.53	61	.44	60
70			6000	85	.53	68	.42	57	70	

Allowance has been made for doffing, waste, cleaning, etc.

{202}

TABLE SHOWING NUMBER OF POUNDS TWISTED YARN PRODUCED IN 10 HOURS—6 PLY.

No. of Yarn to be Twisted	Gauge of Frame	Dia. of Ring	Revs. of Spindle per Minute	Multiplier 4		Multiplier 5		Multiplier 6		No. of Yarn to be Twisted		
				Rev. of 1½-in. Roll per Min.	Pounds per Spindle	Rev. of 1½-in. Roll per Min.	Pounds per Spindle	Rev. of 1½-in. Roll per Min.	Pounds per Spindle			
6	5½	4½	2800	148	11.11	119	8.89	99	7.41	6		
7			2800	137	9.04	110	7.23	92	6.03	7		
8			2800	129	7.49	103	5.99	86	4.99	8		
9			2800	121	6.35	97	5.08	81	4.23	9		
10			2800	115	5.43	92	4.34	77	3.61	10		
12			3300	124	4.92	99	3.94	82	3.28	12		
14			3300	115	3.90	92	3.12	76	2.60	14		
15			3300	107	3.56	89	2.85	74	2.37	15		
16			3300	107	3.23	86	2.59	71	2.15	16		
18			3800	116	3.15	93	2.52	78	2.10	18		
20	4½	3½	3800	110	2.70	88	2.15	74	1.80	20		
22			3800	105	2.33	84	1.87	70	1.56	22		
24			3800	101	2.07	81	1.66	67	1.38	24		
26			3800	97	1.84	78	1.47	65	1.23	26		
28			3800	93	1.65	75	1.32	62	1.10	28		
30			4500	107	1.78	85	1.42	71	1.18	30		
32			4500	103	1.61	83	1.29	69	1.08	32		
34			4500	100	1.47	80	1.18	67	.98	34		
36			4500	97	1.35	78	1.08	65	.90	36		
38			4500	95	1.25	76	1.00	63	.83	38		
40	4	3	4500	91	1.13	74	.92	62	.77	40		
42			5400	108	1.30	87	1.04	72	.87	42		
44			5400	106	1.21	85	.97	71	.81	44		
46			5400	103	1.13	83	.91	69	.76	46		
48			5400	101	1.07	81	.85	68	.71	48		
50			5400	99	1.01	79	.81	66	.68	50		
60			3¼	2¼	6000	101	.86	81	.69	67	.57	60
70					6000	93	.69	75	.55	62	.46	70

Allowance has been made for doffing, waste, cleaning, etc.

{203}

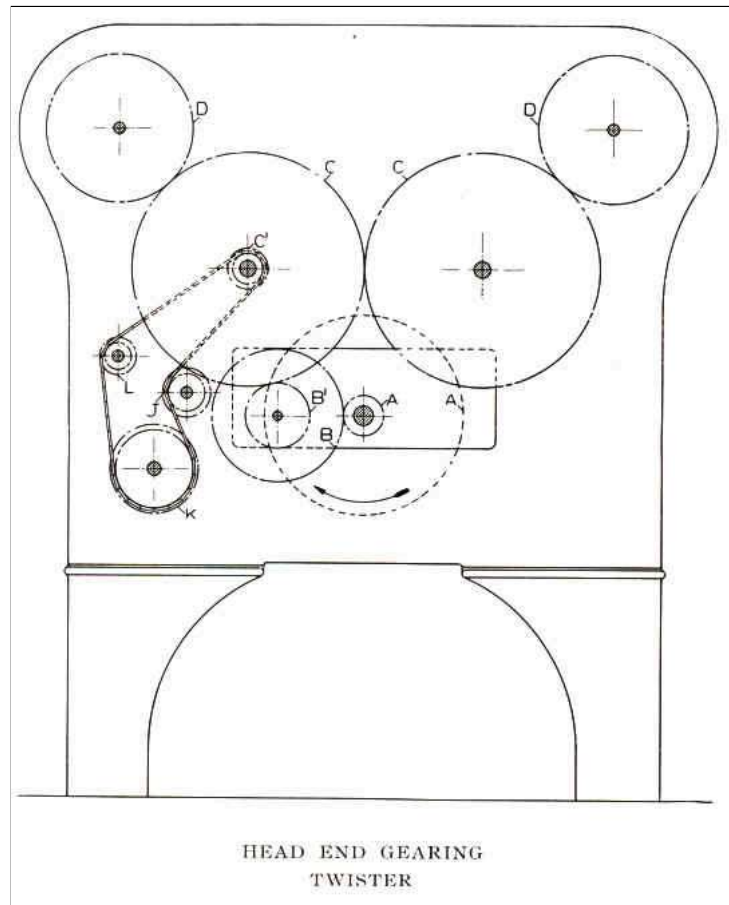

HEAD END GEARING TWISTER

{204}

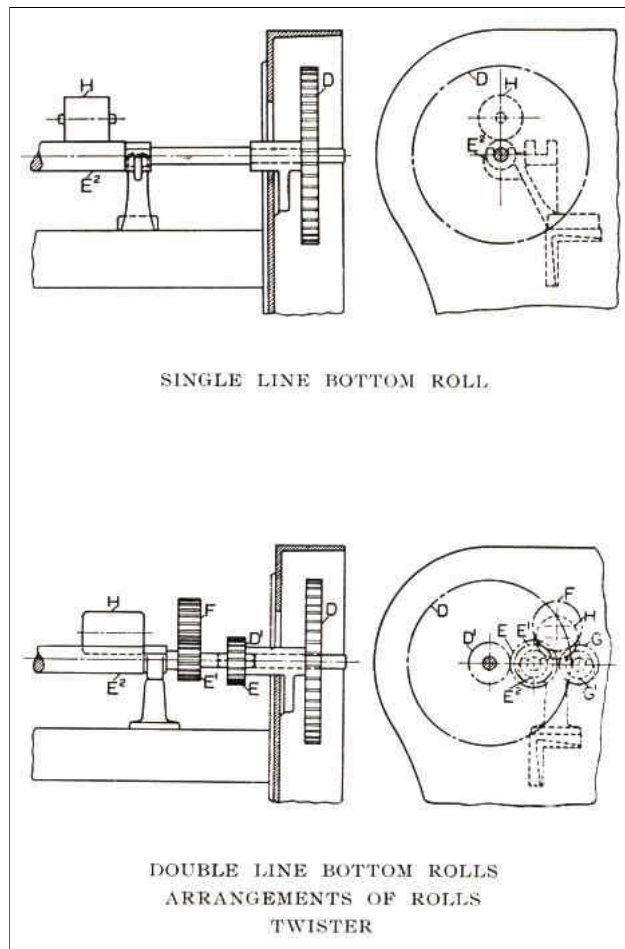

SINGLE LINE BOTTOM ROLL

DOUBLE LINE BOTTOM ROLLS
ARRANGEMENTS OF ROLLS
TWISTER

{205}

TWISTERS.**ALPHABETICAL REFERENCES TO DRAWINGS.**

A Driving Pulley, 8 in. to 18 in. dia., advancing by 1/2 in. increments, 3-1/4 in. face.

A¹ Cylinder Gear, 21, 25, 29, 30, 39 and 49 T.

A² Cylinder, 7 in. and 8 in. dia.

B Jack Gear, 72, 76, 80, 84, 86, 96 and 106 T.

B¹ Twist Change Gear, 25 to 67 T., advancing by one tooth.

C Intermediate Gear, 171 T.

C¹ Builder Motion Driving Sprocket Gear, 8 T.

D Front Roll Twist Gear, 108 and 92 T., Single Line Bottom Roll.
Head End Stud Gear, 108 T., Double Line 1 Bottom Rolls.

D¹ Head End Stud Change Gear, 23, 27, 32 and 36 T.

E Front Roll Change Gear, 36, 32, 27 and 23 T.

E¹ Front Roll Gear, 39 T.

E² Front Roll, 1-1/2 in. dia.

F Back Roll Intermediate Gear, 48 T.

G Back Roll Gear, 40 T.

G¹ Back Roll, 1-1/2 in. dia.

H Top Roll, 2-1/2 in. dia.

I Whorl, 7/8 in., 1-1/8 in., 1-3/8 in., 1-5/8 in. and 2-1/2 in. dia.

J Carrier Sprocket Gear, 10 T.

K Builder Motion Worm Shaft Sprocket Gear, 12, 14, 16, 18, 20, 22 and 24 T., dependent upon the Number of Yarn.

L Carrier Sprocket Gear, 7 T.

NOTE—For Letters A and I refer to Spinning Frame cut on [page 161](#).

{206}

TWISTERS.

TWIST CALCULATIONS.

Rules:

Single Line Bottom Rolls, 1½-in. Dia.

$$\frac{D \times B \times \text{Ratio of Whirl Speed to Cylinder Speed}}{A^1 \times \text{Circum. of Bottom Roll}} = \text{Twist Constant.}$$

$$\frac{\text{Twist Constant}}{\text{Twist Change Gear (B}^1\text{)}} = \text{Twist per inch.}$$

$$\frac{\text{Twist Constant}}{\text{Twist per inch required}} = \text{Twist Change Gear (B}^1\text{).}$$

When figuring the Ratio of Whirl Speed to Cylinder Speed we add 1/8 inch to the diameters to allow for the band.

Examples:

If Cylinder Gear (A¹) = 29 T. Jack Gear (B) = 76 T.
Front Roll Gear (D) = 108 T. Cylinder, 8-in. dia.
Whirl, 1½-in. dia. Ratio of Whirl Speed to Cylinder
Speed = 6.50. Circum. of 1½-in. Bottom Roll = 4.7124:

$$\frac{108 \times 76 \times 6.50}{29 \times 4.7124} = 390.40 = \text{Twist Constant.}$$

If Twist Change Gear (B¹) = 30 T:

$$\frac{390.40}{30} = 13.01 \text{ Turns Twist per inch.}$$

If Twist per inch required = 8.50:

$$\frac{390.40}{8.50} = 46 \text{ T} = \text{Twist Change Gear (B}^1\text{).}$$

Rules:

Double Line Bottom Rolls, 1½-in. dia.

$$\frac{D \times B \times E \times \text{Ratio of Whirl Speed to Cylinder Speed}}{A^1 \times D^1 \times \text{Circum. of Bottom Roll}} = \text{Twist Constant.}$$

$$\frac{\text{Twist Constant}}{\text{Twist Change Gear (B}^1\text{)}} = \text{Twist per inch.}$$

{207}

$$\frac{\text{Twist Constant}}{\text{Twist per inch required}} = \text{Twist Change Gear (B}^1\text{)}.$$

Examples:

If Cylinder Gear (A¹) = 49 T. Jack Gear (B) = 76 T. Head End Stud Gear (D) = 108 T. Head End Stud Change Gear (D¹) = 23 T. Front Roll Change Gear (E) = 36 T. Cylinder, 8-in. dia. Whirl, 2½-in. dia. Ratio of Whirl Speed to Cylinder Speed = 3.095. Circum. of 1½-in. Bottom Roll = 4.7124.

$$\frac{108 \times 76 \times 36 \times 3.095}{49 \times 23 \times 4.7124} = 172.21 = \text{Twist Constant.}$$

If Twist Change Gear (B¹) = 50 T.

$$\frac{172.21}{50} = 3.44 \text{ Turns Twist per inch.}$$

If Twist per inch required = 4.00

$$\frac{172.21}{4.00} = 43 \text{ T.} = \text{Twist Change Gear (B}^1\text{)}.$$

PRODUCTION CALCULATIONS.

Rule:

$$\frac{\text{R. P. M. of Bottom Roll} \times \text{Circum. of Bottom Roll} \times 600 \text{ (min. in 10 hours)}}{36 \text{ (in. in 1 yd.)} \times 840 \text{ (yds. in 1 hank)} \times \text{No. of Twisted Yarn}} = \frac{\text{Lbs. Production per Spindle in 10 hours.}}$$

Example:

If 2 ply 24s Yarn. Twist per inch 5 x Square Root of Twisted Yarn. R. P. M. of 1½-in. Roll = 74. Circum. of 1½-in. Roll = 4.7124. 8 per cent. allowance for stops, etc.

$$\frac{74 \times 4.7124 \times 600 \times .92}{36 \times 840 \times \frac{24}{2}} = .53 \text{ lbs. in 10 hours.}$$

In our production tables on [pages 198 to 202](#) the allowance for doffing, waste, etc., varies with the numbers of twisted yarn, the percentage loss being greater for coarse than fine work. See [pages 196 and 197](#) for percentage deducted.

{208}

TWIST GEARING CONSTANTS FOR TWISTERS.

1-1/2-IN. SINGLE LINE BOTTOM ROLLS. 7-IN. DIA. CYLINDER.

Dia. of Whirl	Ratio Whirl to Cylinder	Front Roll Gear	Cylinder, 29T Jack, 76T Constant	Cylinder, 29T Jack, 96T Constant	Cylinder, 21T Jack, 96T Constant	Cylinder, 21T Jack, 100T Constant	Cylinder, 17T Jack, 106T Constant	Cylinder, 15T Jack, 119T Constant
7/8	7.125	108	427.94	540.55	746.48	824.24	1018.18	1295.45
1	6.333	108	380.39	480.49	663.54	732.66	905.05	1151.51
1 1/8	5.700	108	342.35	432.44	597.18	659.39	814.54	1036.45
1 1/4	5.182	108	311.23	393.13	542.89	599.45	740.49	942.15
1 3/8	4.750	108	285.29	360.40	497.65	549.49	678.78	863.63
1 1/2	4.384	108	263.35	332.65	459.37	507.22	626.57	797.20
1 5/8	4.071	108	244.54	308.91	426.56	470.99	581.81	740.26
1 1/2-IN. SINGLE LINE BOTTOM ROLLS. 8-IN. DIA. CYLINDER.								
1 1/8	6.500	108	390.40	493.14	681.00	751.94	928.94	1181.92
1 1/4	5.909	108	354.91	448.31	619.14	683.58	844.42	1074.38
1 3/8	5.417	108	325.33	410.95	567.50	626.61	774.42	984.85
1 1/2	5.000	108	300.31	379.34	523.85	578.46	714.51	909.09
1 5/8	4.643	108	278.86	352.24	486.43	537.14	663.47	844.16
2 1/2	3.095	108	185.91	234.83	324.29	358.10	442.32	562.77
2 3/4	3.095	92	158.36	200.04	276.24	305.02	376.78	479.39

Rule to find change gear: Divide Constant by Twist per inch required.

{209}

TWIST GEARING CONSTANTS FOR TWISTERS.

1-1/2-IN. DOUBLE LINE BOTTOM ROLLS. 8-IN. DIA. CYLINDER.

Dia. of Whirl	Ratio Whirl to Cylinder	Head End Stud Gear	Head End Stud Change Gear	Front Roll Change Gear	Cylinder, 49 T Jack, 76 T Constant	Cylinder, 39 T Jack, 86 T Constant	Cylinder, 29 T Jack, 96 T Constant	Cylinder, 25 T Jack, 96 T Constant
1 5/8	4.643	108	23	36	258.32	367.26	551.33	639.55
1 3/8	4.643	108	27	32	195.60	278.09	417.47	484.27
1 5/8	4.643	108	32	27	139.25	197.98	297.20	344.76
1 3/8	4.643	108	36	23	105.44	149.91	225.04	261.05
2 1/2	3.095	108	23	36	172.21	244.84	367.56	426.36
2 1/2	3.095	108	27	32	130.40	185.39	278.31	322.84
2 1/2	3.095	108	32	27	92.83	131.98	198.14	229.84
2 1/2	3.095	108	36	23	70.29	99.94	150.03	174.03

Rule to find change gear: Divide Constant by Twist per inch required.

{210}

TWIST TABLE FOR TWISTERS.

1-1/2 IN. SINGLE LINE BOTTOM ROLLS. FRONT ROLL GEAR, 108. 1-1/8 IN. DIA. WHIRL ON SPINDLE.

Twist Change Gear	Cylinder, 7 in. Dia. Ratio Whirl to Cyl., 3.70				Cylinder, 8 in. Dia. Ratio Whirl to Cyl., 6.50				
	Jack 96 Cyl. 29	Jack 96 Cyl. 21	Jack 106 Cyl. 21	Jack 119 Cyl. 15	Jack 96 Cyl. 29	Jack 96 Cyl. 21	Jack 106 Cyl. 21	Jack 106 Cyl. 17	Jack 119 Cyl. 15
	Twist	Twist	Twist	Twist	Twist	Twist	Twist	Twist	Twist
25	17.30	23.89	26.38	41.46	19.73	27.24	30.36	37.16	47.28
26	16.63	22.97	25.36	39.86	18.97	26.19	28.92	35.73	45.46
27	16.02	22.12	24.42	38.39	18.26	25.22	27.85	34.41	43.78
28	15.44	21.33	23.55	37.02	17.61	24.32	26.85	33.18	42.21
29	14.91	20.59	22.74	35.74	17.00	23.48	25.93	32.03	40.76
30	14.41	19.91	21.98	34.55	16.44	22.70	25.06	30.96	39.40
31	13.95	19.26	21.27	33.43	15.91	21.97	24.26	29.97	38.13
32	13.51	18.66	20.61	32.39	15.41	21.28	23.50	29.03	36.93
33	13.10	18.10	19.98	31.41	14.94	20.64	22.79	28.15	35.82
34	12.72	17.56	19.39	30.48	14.50	20.03	22.12	27.32	34.76
35	12.36	17.06	18.84	29.61	14.09	19.46	21.48	26.54	33.77
36	12.01	16.59	18.32	28.79	13.70	18.92	20.89	25.80	32.83
37	11.69	16.14	17.82	28.01	13.33	18.41	20.32	25.11	31.94
38	11.38	15.72	17.35	27.28	12.98	17.92	19.79	24.45	31.10
39	11.09	15.31	16.91	26.58	12.64	17.46	19.28	23.82	30.31
40	10.81	14.93	16.48	25.91	12.33	17.03	18.80	23.22	29.55
41	10.55	14.57	16.08	25.28	12.03	16.61	18.34	22.66	28.83
42	10.30	14.22	15.70	24.68	11.74	16.21	17.90	22.12	28.14
43	10.06	13.89	15.33	24.10	11.47	15.84	17.49	21.60	27.49
44	9.83	13.57	14.99	23.56	11.21	15.48	17.09	21.11	26.86
45	9.61	13.27	14.65	23.03	10.96	15.13	16.71	20.64	26.27
46	9.40	12.98	14.33	22.53	10.72	14.80	16.35	20.19	25.69
47	9.20	12.71	14.03	22.05	10.49	14.49	16.00	19.76	25.15
48	9.01	12.44	13.74	21.59	10.27	14.19	15.67	19.35	24.62
49	8.82	12.19	13.46	21.15	10.06	13.90	15.35	18.96	24.12
50	8.65	11.94	13.19	20.73	9.86	13.62	15.04	18.58	23.64
51	8.48	11.71	12.93	20.32	9.67	13.35	14.74	18.21	23.17
52	8.32	11.48	12.68	19.93	9.48	13.10	14.46	17.86	22.73
53	8.16	11.27	12.44	19.56	9.30	12.85	14.19	17.53	22.30
54	8.01	11.06	12.21	19.19	9.13	12.61	13.92	17.20	21.89
55	7.86	10.86	11.99	18.84	8.97	12.38	13.67	16.89	21.49
56	7.72	10.66	11.77	18.51	8.81	12.16	13.43	16.59	21.11
57	7.59	10.48	11.57	18.18	8.65	11.95	13.19	16.30	20.74
58	7.46	10.30	11.37	17.87	8.50	11.74	12.96	16.02	20.38
59	7.33	10.12	11.18	17.57	8.36	11.54	12.74	15.74	20.03
60	7.21	9.95	10.99	17.27	8.22	11.35	12.53	15.48	19.70
61	7.09	9.79	10.81	16.99	8.08	11.16	12.33	15.23	19.38
62	6.97	9.63	10.64	16.72	7.95	10.98	12.13	14.98	19.06
63	6.86	9.48	10.47	16.45	7.83	10.81	11.94	14.75	18.76
64	6.76	9.33	10.30	16.19	7.70	10.64	11.75	14.51	18.47
65	6.65	9.19	10.14	15.95	7.59	10.48	11.57	14.29	18.18
66	6.55	9.05	9.99	15.70	7.47	10.32	11.39	14.08	17.91
67	6.45	8.91	9.84	15.47	7.36	10.16	11.22	13.86	17.64

{211}

TWIST TABLE FOR TWISTERS.

1-1/2 IN. SINGLE LINE BOTTOM ROLLS. FRONT ROLL GEAR, 108. 1-3/8 IN. DIA. WHIRL ON SPINDLE.

Twist Change Gear	Cylinder, 7 in. Dia. Ratio Whirl to Cyl., 4.75				Cylinder, 8 in. Dia. Ratio Whirl to Cylinder, 5.417				
	Jack 96 Cyl. 29	Jack 96 Cyl. 21	Jack 106 Cyl. 21	Jack 106 Cyl. 17	Jack 96 Cyl. 20	Jack 96 Cyl. 21	Jack 106 Cyl. 21	Jack 106 Cyl. 17	Jack 119 Cyl. 15
	Twist	Twist	Twist	Twist	Twist	Twist	Twist	Twist	Twist
25	14.42	19.91	21.98	27.15	16.44	22.70	25.06	30.98	39.39
26	13.86	19.14	21.13	26.11	15.81	21.83	24.10	29.79	37.88
27	13.35	18.43	20.35	25.14	15.22	21.02	23.21	28.68	36.48
28	12.87	17.77	19.62	24.24	14.68	20.27	22.38	27.65	35.17
29	12.43	17.16	18.95	23.41	14.17	19.57	21.61	26.70	33.96
30	12.01	16.59	18.32	22.63	13.70	18.92	20.89	25.81	32.83
31	11.63	16.05	17.73	21.90	13.26	18.31	20.21	24.98	31.77
32	11.26	15.55	17.17	21.21	12.84	17.73	19.58	24.20	30.78
33	10.92	15.08	16.65	20.57	12.45	17.20	18.99	23.47	29.84
34	10.60	14.64	16.16	19.96	12.09	16.69	18.43	22.78	28.97
35	10.30	14.22	15.70	19.39	11.74	16.21	17.90	22.13	28.14
36	10.01	13.82	15.26	18.86	11.42	15.76	17.41	21.51	27.36
37	9.74	13.45	14.85	18.37	11.11	15.34	16.94	20.93	26.62
38	9.48	13.10	14.46	17.96	10.82	14.93	16.49	20.38	25.92
39	9.24	12.76	14.09	17.40	10.54	14.55	16.07	19.86	25.25
40	9.01	12.44	13.74	16.97	10.27	14.19	15.67	19.36	24.62
41	8.79	12.14	13.40	16.56	10.02	13.84	15.28	18.89	24.02
42	8.58	11.85	13.08	16.16	9.78	13.51	14.92	18.44	23.45
43	8.38	11.57	12.78	15.79	9.56	13.20	14.57	18.01	22.90
44	8.19	11.31	12.49	15.43	9.34	12.90	14.24	17.60	22.38
45	8.01	11.06	12.21	15.08	9.13	12.61	13.92	17.21	21.89
46	7.83	10.82	11.95	14.76	8.93	12.34	13.62	16.84	21.41
47	7.67	10.59	11.69	14.44	8.74	12.07	13.33	16.48	20.95
48	7.51	10.37	11.45	14.14	8.56	11.82	13.05	16.13	20.52
49	7.35	10.16	11.21	13.85	8.39	11.58	12.79	15.80	20.10
50	7.21	9.95	10.99	13.58	8.22	11.35	12.53	15.49	19.70
51	7.07	9.76	10.77	13.31	8.06	11.13	12.29	15.18	19.31
52	6.93	9.57	10.57	13.05	7.90	10.91	12.05	14.89	18.94
53	6.80	9.39	10.37	12.81	7.75	10.71	11.82	14.61	18.58
54	6.67	9.22	10.18	12.57	7.61	10.51	11.60	14.34	18.24
55	6.55	9.05	9.99	12.34	7.47	10.32	11.38	14.08	17.91
56	6.44	8.89	9.81	12.12	7.34	10.13	11.19	13.83	17.59
57	6.32	8.73	9.64	11.91	7.21	9.96	10.99	13.59	17.28
58	6.21	8.58	9.47	11.70	7.08	9.78	10.80	13.35	16.98
59	6.11	8.43	9.31	11.50	6.96	9.62	10.62	13.13	16.69
60	6.01	8.29	9.16	11.31	6.85	9.46	10.44	12.91	16.41
61	5.91	8.16	9.01	11.13	6.74	9.30	10.27	12.70	16.15
62	5.81	8.03	8.86	10.95	6.63	9.15	10.11	12.49	15.88
63	5.72	7.90	8.72	10.77	6.52	9.01	9.95	12.29	15.63
64	5.63	7.78	8.59	10.61	6.42	8.87	9.79	12.10	15.39
65	5.54	7.66	8.45	10.44	6.32	8.73	9.64	11.91	15.15
66	5.46	7.54	8.33	10.28	6.23	8.60	9.49	11.73	14.92
67	5.38	7.43	8.20	10.13	6.13	8.47	9.35	11.56	14.70

{212}

TWIST TABLE FOR TWISTERS.

1-1/2 IN. SINGLE LINE BOTTOM ROLLS. FRONT ROLL GEAR, 108. 1-5/8 IN. DIA. WHIRL ON SPINDLE.

Twist Change Gear	Cylinder, 7 in. Dia. Ratio Whirl to Cyl., 4.071				Cylinder, 8 in. Dia. Ratio Whirl to Cyl., 4.643				
	Jack 96 Cyl. 29	Jack 96 Cyl. 21	Jack 106 Cyl. 21	Jack 106 Cyl. 17	Jack 96 Cyl. 29	Jack 96 Cyl. 21	Jack 106 Cyl. 21	Jack 106 Cyl. 17	Jack 119 Cyl. 15
	Twist	Twist	Twist	Twist	Twist	Twist	Twist	Twist	Twist
25	12.26	17.06	18.84	23.27	14.09	19.46	21.49	26.54	33.77
26	11.88	16.41	18.11	22.38	13.55	18.71	20.66	25.52	32.47
27	11.44	15.80	17.44	21.55	13.05	18.02	19.89	24.57	31.27
28	11.03	15.23	16.82	20.78	12.58	17.37	19.18	23.69	30.15
29	10.65	14.71	16.24	20.06	12.15	16.77	18.52	22.88	29.11
30	10.30	14.22	15.70	19.39	11.74	16.21	17.90	22.12	28.14
31	9.96	13.76	15.19	18.77	11.36	15.69	17.33	21.40	27.23
32	9.65	13.33	14.72	18.18	11.01	15.20	16.79	20.73	26.38
33	9.36	12.93	14.27	17.63	10.67	14.74	16.28	20.11	25.58
34	9.09	12.55	13.85	17.11	10.36	14.31	15.80	19.51	24.89
35	8.83	12.19	13.46	16.62	10.06	13.90	15.35	18.96	24.12
36	8.58	11.85	13.08	16.16	9.78	13.51	14.92	18.49	23.45
37	8.35	11.53	12.73	15.72	9.52	13.15	14.52	17.99	22.82
38	8.13	11.23	12.39	15.31	9.27	12.80	14.14	17.46	22.22
39	7.92	10.94	12.08	14.92	9.03	12.47	13.77	17.01	21.65
40	7.72	10.66	11.77	14.55	8.81	12.16	13.43	16.59	21.10
41	7.53	10.40	11.49	14.19	8.59	11.86	13.10	16.18	20.59
42	7.35	10.16	11.21	13.85	8.39	11.58	12.79	15.80	20.10
43	7.18	9.92	10.95	13.53	8.19	11.31	12.49	15.43	19.63
44	7.02	9.69	10.70	13.22	8.00	11.06	12.21	15.08	19.19
45	6.86	9.48	10.47	12.93	7.83	10.81	11.94	14.74	18.76
46	6.72	9.27	10.24	12.65	7.66	10.57	11.68	14.42	18.35
47	6.57	9.08	10.02	12.38	7.49	10.35	11.43	14.12	17.96
48	6.44	8.89	9.81	12.12	7.34	10.13	11.19	13.82	17.59
49	6.30	8.70	9.61	11.87	7.19	9.93	10.96	13.54	17.23
50	6.18	8.53	9.42	11.64	7.04	9.73	10.74	13.27	16.88
51	6.06	8.36	9.23	11.41	6.91	9.54	10.53	13.01	16.56
52	5.94	8.20	9.06	11.19	6.77	9.35	10.33	12.76	16.23
53	5.83	8.05	8.89	10.98	6.65	9.18	10.13	12.52	15.93
54	5.72	7.90	8.72	10.77	6.52	9.01	9.95	12.29	15.63
55	5.62	7.76	8.56	10.58	6.40	8.84	9.77	12.06	15.35
56	5.52	7.62	8.41	10.39	6.29	8.69	9.59	11.85	15.07
57	5.42	7.48	8.26	10.21	6.18	8.53	9.42	11.64	14.81
58	5.33	7.35	8.12	10.03	6.07	8.39	9.26	11.44	14.55
59	5.24	7.23	7.98	9.86	5.97	8.24	9.10	11.25	14.31
60	5.15	7.11	7.85	9.70	5.87	8.11	8.95	11.06	14.07
61	5.06	6.99	7.72	9.54	5.77	7.97	8.81	10.88	13.84
62	4.98	6.88	7.60	9.38	5.68	7.85	8.66	10.70	13.62
63	4.90	6.77	7.48	9.23	5.59	7.72	8.53	10.53	13.40
64	4.83	6.66	7.36	9.09	5.50	7.60	8.39	10.37	13.19
65	4.75	6.56	7.25	8.95	5.42	7.48	8.26	10.21	12.99
66	4.68	6.46	7.14	8.82	5.34	7.37	8.14	10.05	12.79
67	4.61	6.37	7.03	8.68	5.26	7.26	8.02	9.90	12.60

{213}

TWIST TABLE FOR TWISTERS.

1-1/2 IN. SINGLE LINE BOTTOM ROLLS. 8 IN. DIA. CYLINDER. 2-1/2 IN. DIA. WHIRL ON SPINDLE.

Twist Change Gear	Front Roll Gear, 108 Ratio Whirl to Cylinder, 3.095					Front Roll Gear, 92 Ratio Whirl to Cyl., 3.095			
	Jack 76 Cyl. 29	Jack 96 Cyl. 29	Jack 96 Cyl. 21	Jack 106 Cyl. 21	Jack 106 Cyl. 17	Jack 76 Cyl. 29	Jack 96 Cyl. 21	Jack 106 Cyl. 21	Jack 106 Cyl. 17
	Twist	Twist	Twist	Twist	Twist	Twist	Twist	Twist	Twist
25	7.44	9.39	12.97	14.32	17.69	6.33	11.05	12.20	15.07
26	7.15	9.03	12.47	13.77	17.01	6.09	10.62	11.73	14.49
27	6.89	8.70	12.01	13.26	16.38	5.86	10.23	11.30	13.95
28	6.64	8.39	11.58	12.79	15.80	5.66	9.87	10.89	13.46
29	6.41	8.10	11.18	12.35	15.25	5.46	9.53	10.52	12.99
30	6.20	7.83	10.81	11.94	14.74	5.28	9.21	10.17	12.56
31	6.00	7.58	10.46	11.59	14.27	5.11	8.91	9.84	12.15
32	5.81	7.34	10.13	11.19	13.82	4.95	8.63	9.53	11.77
33	5.63	7.12	9.83	10.85	13.40	4.80	8.37	9.24	11.42
34	5.47	6.91	9.54	10.53	13.01	4.66	8.12	8.97	11.08
35	5.31	6.71	9.27	10.23	12.64	4.52	7.89	8.71	10.77
36	5.16	6.52	9.01	9.95	12.29	4.40	7.67	8.47	10.47
37	5.02	6.35	8.76	9.68	11.95	4.28	7.47	8.24	10.18
38	4.89	6.18	8.53	9.42	11.64	4.17	7.27	8.03	9.92
39	4.77	6.02	8.32	9.18	11.34	4.06	7.08	7.82	9.66
40	4.65	5.87	8.11	8.95	11.06	3.96	6.91	7.63	9.42
41	4.53	5.73	7.91	8.73	10.79	3.86	6.74	7.44	9.19
42	4.43	5.59	7.72	8.53	10.53	3.77	6.58	7.26	8.97
43	4.32	5.46	7.54	8.33	10.29	3.68	6.43	7.09	8.76
44	4.23	5.34	7.37	8.14	10.05	3.60	6.28	6.93	8.56
45	4.13	5.22	7.21	7.96	9.83	3.52	6.14	6.78	8.37
46	4.04	5.10	7.05	7.78	9.62	3.44	6.01	6.63	8.19
47	3.96	5.00	6.90	7.62	9.41	3.37	5.88	6.49	8.02
48	3.87	4.90	6.76	7.46	9.21	3.30	5.75	6.35	7.85
49	3.79	4.79	6.62	7.31	9.03	3.23	5.64	6.22	7.69
50	3.72	4.70	6.49	7.16	8.85	3.17	5.52	6.10	7.54
51	3.65	4.60	6.36	7.02	8.67	3.10	5.42	5.98	7.39
52	3.58	4.52	6.24	6.89	8.51	3.05	5.31	5.87	7.25
53	3.51	4.43	6.12	6.76	8.35	2.99	5.21	5.75	7.11
54	3.44	4.35	6.01	6.63	8.19	2.93	5.12	5.65	6.98
55	3.38	4.27	5.90	6.51	8.04	2.88	5.02	5.55	6.85
56	3.32	4.19	5.79	6.39	7.90	2.83	4.93	5.45	6.73
57	3.26	4.12	5.69	6.28	7.76	2.78	4.85	5.35	6.61
58	3.21	4.05	5.59	6.17	7.63	2.73	4.76	5.26	6.50
59	3.15	3.98	5.50	6.07	7.50	2.68	4.68	5.17	6.39
60	3.10	3.91	5.40	5.97	7.37	2.64	4.60	5.08	6.28
61	3.05	3.85	5.32	5.87	7.25	2.60	4.53	5.00	6.18
62	3.00	3.79	5.23	5.78	7.13	2.55	4.46	4.92	6.08
63	2.95	3.73	5.15	5.68	7.02	2.51	4.38	4.84	5.98
64	2.90	3.67	5.07	5.60	6.91	2.47	4.32	4.77	5.89
65	2.86	3.61	4.99	5.51	6.80	2.44	4.25	4.69	5.80
66	2.82	3.56	4.91	5.43	6.70	2.40	4.19	4.62	5.71
67	2.77	3.50	4.84	5.34	6.60	2.36	4.12	4.55	5.62

{214}

TWIST TABLE FOR TWISTERS.

1-1/2 IN. DOUBLE LINE BOTTOM ROLLS. 8 IN. DIA. CYLINDER. 1-5/8 IN. DIA. WHIRL ON SPINDLE.
HEAD END STUD GEAR, 108 T.

Twist Change Gear	D ¹ =36 E=23 Cyl. 49 Jack 76	D ¹ =32 E=27 Cyl. 49 Jack 76	D ¹ =27 E=32 Cyl. 49 Jack 76	D ¹ =32 E=27 Cyl. 39 Jack 86	D ¹ =27 E=32 Cyl. 39 Jack 86	D ¹ =36 E=23 Cyl. 29 Jack 96	D ¹ =32 E=27 Cyl. 29 Jack 96	D ¹ =27 E=32 Cyl. 29 Jack 96	D ¹ =23 E=36 Cyl. 29 Jack 96
	Twist	Twist	Twist	Twist	Twist	Twist	Twist	Twist	Twist
25	4.22	5.57	7.82	7.92	11.12	9.00	11.89	16.70	22.05
26	4.06	5.30	7.52	7.61	10.70	8.66	11.43	16.06	21.20
27	3.91	5.16	7.24	7.33	10.30	8.33	11.01	15.46	20.42
28	3.77	4.97	6.99	7.07	9.93	8.04	10.61	14.91	19.69
29	3.64	4.80	6.74	6.83	9.59	7.76	10.25	14.40	19.01
30	3.51	4.64	6.52	6.60	9.27	7.50	9.91	13.92	18.38
31	3.40	4.49	6.31	6.39	8.97	7.26	9.59	13.47	17.78
32	3.29	4.35	6.11	6.19	8.69	7.03	9.29	13.05	17.23
33	3.20	4.22	5.93	6.00	8.43	6.82	9.01	12.65	16.71
34	3.10	4.10	5.75	5.82	8.18	6.62	8.74	12.28	16.21
35	3.01	3.98	5.59	5.66	7.95	6.43	8.49	11.93	15.75
36	2.93	3.87	5.43	5.50	7.72	6.25	8.26	11.60	15.31
37	2.85	3.76	5.29	5.35	7.52	6.08	8.03	11.28	14.90
38	2.77	3.66	5.15	5.21	7.32	5.92	7.82	10.99	14.51
39	2.70	3.57	5.02	5.08	7.13	5.77	7.62	10.70	14.14
40	2.64	3.48	4.89	4.95	6.95	5.63	7.43	10.44	13.78
41	2.57	3.40	4.77	4.83	6.78	5.49	7.25	10.18	13.45
42	2.51	3.32	4.66	4.71	6.62	5.36	7.08	9.94	13.13
43	2.45	3.24	4.55	4.60	6.47	5.23	6.91	9.71	12.82
44	2.40	3.16	4.45	4.50	6.32	5.11	6.75	9.49	12.53
45	2.34	3.09	4.35	4.40	6.18	5.00	6.60	9.28	12.25
46	2.29	3.03	4.25	4.30	6.05	4.89	6.46	9.08	11.99
47	2.24	2.96	4.16	4.21	5.92	4.79	6.32	8.88	11.73
48	2.20	2.90	4.07	4.12	5.79	4.69	6.19	8.70	11.49
49	2.15	2.84	3.99	4.04	5.68	4.59	6.07	8.52	11.25
50	2.11	2.78	3.91	3.96	5.56	4.50	5.94	8.35	11.03
51	2.07	2.73	3.84	3.88	5.45	4.41	5.83	8.19	10.81
52	2.03	2.67	3.76	3.81	5.35	4.33	5.72	8.03	10.60
53	1.99	2.63	3.69	3.74	5.25	4.25	5.61	7.88	10.40
54	1.95	2.58	3.62	3.67	5.15	4.17	5.50	7.73	10.21
55	1.92	2.53	3.56	3.60	5.06	4.09	5.40	7.59	10.02
56	1.88	2.49	3.49	3.54	4.97	4.02	5.31	7.45	9.84
57	1.85	2.44	3.43	3.47	4.88	3.95	5.21	7.32	9.67
58	1.82	2.40	3.37	3.41	4.79	3.88	5.12	7.20	9.51
59	1.79	2.36	3.32	3.36	4.71	3.81	5.04	7.08	9.34
60	1.76	2.32	3.26	3.30	4.63	3.75	4.95	6.96	9.19
61	1.73	2.28	3.21	3.25	4.56	3.69	4.87	6.84	9.04
62	1.70	2.25	3.15	3.19	4.49	3.63	4.79	6.73	8.89
63	1.67	2.21	3.10	3.14	4.41	3.57	4.72	6.63	8.75
64	1.65	2.18	3.05	3.09	4.35	3.52	4.64	6.52	8.61
65	1.62	2.14	3.01	3.05	4.28	3.46	4.57	6.42	8.48
66	1.59	2.11	2.96	3.00	4.21	3.41	4.50	6.33	8.35
67	1.57	2.08	2.92	2.95	4.15	3.36	4.44	6.23	8.23

NOTE-D¹ = Head End Stud Change Gear.
 E = Front Roll Change Gear.
 Ratio Whirl to Cylinder Speed, 4.643.

{215}

TWIST TABLE FOR TWISTERS.

1-1/2 IN. DOUBLE LINE BOTTOM ROLLS. 8 IN. DIA. CYLINDER. 2-1/2 IN. DIA. WHIRL ON SPINDLE.
 HEAD END STUD GEAR, 108.

Twist Change Gear	D ¹ =36 E=23 Cyl. 49 Jack 76	D ¹ =32 E=27 Cyl. 49 Jack 76	D ¹ =27 E=32 Cyl. 49 Jack 76	D ¹ =23 E=36 Cyl. 49 Jack 76	D ¹ =36 E=23 Cyl. 29 Jack 96	D ¹ =32 E=27 Cyl. 29 Jack 96	D ¹ =27 E=32 Cyl. 29 Jack 96	D ¹ =23 E=36 Cyl. 29 Jack 96	D ¹ =23 E=36 Cyl. 25 Jack 96
	Twist	Twist	Twist	Twist	Twist	Twist	Twist	Twist	Twist
25	2.81	3.71	5.22	6.89	6.00	7.93	11.13	14.70	17.05
26	2.70	3.57	5.02	6.62	5.77	7.62	10.70	14.14	16.40
27	2.60	3.44	4.83	6.38	5.56	7.34	10.31	13.61	15.79
28	2.51	3.32	4.66	6.15	5.36	7.08	9.94	13.13	15.23
29	2.42	3.20	4.50	5.94	5.17	6.83	9.60	12.67	14.70
30	2.34	3.09	4.35	5.74	5.00	6.60	9.28	12.25	14.21
31	2.27	2.99	4.21	5.56	4.84	6.39	8.98	11.86	13.75
32	2.20	2.90	4.07	5.38	4.69	6.19	8.70	11.49	13.32
33	2.13	2.81	3.95	5.22	4.55	6.00	8.43	11.14	12.92
34	2.07	2.73	3.84	5.06	4.41	5.83	8.19	10.81	12.54
35	2.01	2.65	3.73	4.92	4.29	5.66	7.95	10.50	12.18
36	1.95	2.58	3.62	4.78	4.17	5.50	7.73	10.21	11.84
37	1.90	2.51	3.52	4.65	4.05	5.35	7.52	9.93	11.52
38	1.85	2.44	3.43	4.53	3.95	5.21	7.32	9.67	11.22
39	1.80	2.38	3.34	4.42	3.85	5.08	7.14	9.42	10.93
40	1.76	2.32	3.26	4.31	3.75	4.95	6.96	9.19	10.66
41	1.71	2.26	3.18	4.20	3.66	4.83	6.79	8.96	10.40
42	1.67	2.21	3.10	4.10	3.57	4.72	6.63	8.75	10.15
43	1.63	2.16	3.03	4.00	3.49	4.61	6.47	8.55	9.92
44	1.60	2.11	2.96	3.91	3.41	4.50	6.33	8.35	9.69
45	1.56	2.06	2.90	3.83	3.33	4.40	6.18	8.17	9.47
46	1.53	2.01	2.83	3.74	3.26	4.31	6.05	7.99	9.27
47	1.50	1.97	2.77	3.66	3.19	4.22	5.92	7.82	9.07
48	1.46	1.93	2.72	3.59	3.13	4.13	5.80	7.66	8.88
49	1.43	1.89	2.66	3.51	3.06	4.04	5.68	7.50	8.70
50	1.41	1.86	2.61	3.44	3.00	3.96	5.57	7.35	8.53
51	1.38	1.82	2.56	3.38	2.94	3.89	5.46	7.21	8.36
52	1.35	1.79	2.51	3.31	2.89	3.81	5.35	7.07	8.20
53	1.33	1.75	2.46	3.25	2.83	3.74	5.25	6.93	8.04
54	1.30	1.72	2.41	3.19	2.78	3.67	5.15	6.81	7.90
55	1.28	1.69	2.37	3.13	2.73	3.60	5.06	6.68	7.75
56	1.26	1.66	2.33	3.08	2.68	3.54	4.97	6.56	7.61
57	1.23	1.63	2.29	3.02	2.63	3.48	4.88	6.45	7.48
58	1.21	1.60	2.25	2.97	2.59	3.42	4.80	6.34	7.35
59	1.19	1.57	2.21	2.92	2.54	3.36	4.72	6.23	7.23
60	1.17	1.55	2.17	2.87	2.50	3.30	4.64	6.13	7.11
61	1.15	1.52	2.14	2.82	2.46	3.25	4.56	6.03	6.99
62	1.13	1.50	2.10	2.78	2.42	3.20	4.49	5.93	6.88
63	1.12	1.47	2.07	2.73	2.38	3.15	4.42	5.83	6.77
64	1.10	1.45	2.04	2.69	2.34	3.10	4.35	5.74	6.66
65	1.08	1.43	2.01	2.65	2.31	3.05	4.28	5.65	6.56
66	1.06	1.41	1.98	2.61	2.27	3.00	4.22	5.57	6.46
67	1.05	1.39	1.95	2.57	2.24	2.96	4.15	5.49	6.36

NOTE-D¹ = Head End Stud Change Gear.
 E = Front Roll Change Gear.
 Ratio Whirl to Cylinder Speed, 3.095.

{216}

TWIST TABLES FOR 2 PLY.

No. of Yarn to be Twisted	No. of Twisted Yarn	Square Root of No. Twisted Yarn	Square Root Multiplied by			No. of Yarn to be Twisted	No. of Twisted Yarn	Square Root of No. Twisted Yarn	Square Root Multiplied by		
			4	5	6				4	5	6
1	.5	.7071	2.83	3.54	4.24	51	25.5	5.0498	20.20	25.25	30.30
2	1	1	4	5	6	52	26	5.0990	20.40	25.50	30.50
3	1.5	1.2247	4.90	6.12	7.35	53	26.5	5.1478	20.50	25.74	30.89
4	2	1.4142	5.66	7.07	8.49	54	27	5.1962	20.78	25.98	31.18
5	2.5	1.5811	6.32	7.91	9.49	55	27.5	5.2440	20.98	26.22	31.40
6	3	1.7321	6.93	8.66	10.39	56	28	5.2915	21.17	26.46	31.75
7	3.5	1.8708	7.48	9.35	11.22	57	28.5	5.3385	21.35	26.69	32.03
8	4	2	8	10	12	58	29	5.3852	21.54	26.93	32.31
9	4.5	2.1213	8.49	10.61	12.73	59	29.5	5.4314	21.73	27.16	32.59
10	5	2.2361	8.94	11.18	13.42	60	30	5.4772	21.91	27.39	32.86
11	5.5	2.3452	9.38	11.73	14.07	61	30.5	5.5227	22.09	27.61	33.14
12	6	2.4495	9.80	12.25	14.70	62	31	5.5678	22.27	27.84	33.41
13	6.5	2.5495	10.20	12.75	15.30	63	31.5	5.6125	22.45	28.06	33.67
14	7	2.6458	10.58	13.23	15.87	64	32	5.6569	22.63	28.28	33.94
15	7.5	2.7386	10.95	13.69	16.43	65	32.5	5.7009	22.80	28.50	34.21
16	8	2.8284	11.31	14.14	16.97	66	33	5.7446	22.98	28.72	34.47
17	8.5	2.9155	11.66	14.58	17.49	67	33.5	5.7879	23.15	28.94	34.73
18	9	3	12	15	18	68	34	5.8310	23.32	29.15	34.99
19	9.5	3.0822	12.33	15.41	18.49	69	34.5	5.8737	23.49	29.37	35.24
20	10	3.1623	12.65	15.81	18.97	70	35	5.9161	23.66	29.58	35.50
21	10.5	3.2404	12.96	16.20	19.44	71	35.5	5.9582	23.83	29.79	35.75
22	11	3.3166	13.27	16.58	19.90	72	36	6	24	30	36
23	11.5	3.3912	13.56	16.96	20.35	73	36.5	6.0415	24.17	30.21	36.25
24	12	3.4641	13.86	17.32	20.78	74	37	6.0828	24.33	30.41	36.50
25	12.5	3.5355	14.14	17.68	21.21	75	37.5	6.1237	24.49	30.62	36.74
26	13	3.6056	14.42	18.03	21.63	76	38	6.1644	30.82	36.99
27	13.5	3.6742	14.70	18.37	22.05	77	38.5	6.2049	31.02	37.23
28	14	3.7417	14.97	18.71	22.45	78	39	6.2450	31.22	37.47
29	14.5	3.8079	15.23	19.04	22.85	79	39.5	6.2849	31.42	37.71
30	15	3.8730	15.49	19.37	23.24	80	40	6.3246	31.62	37.95
31	15.5	3.9370	15.75	19.69	23.62	81	40.5	6.3640	31.82	38.18
32	16	4	16	20	24	82	41	6.4031	32.02	38.42
33	16.5	4.0020	16.25	20.31	24.37	83	41.5	6.4420	32.21	38.65
34	17	4.1231	16.49	20.62	24.74	84	42	6.4807	32.40	38.88
35	17.5	4.1833	16.73	20.92	25.10	85	42.5	6.5192	32.60	39.12
36	18	4.2426	16.97	21.21	25.46	86	43	6.5574	32.79	39.34
37	18.5	4.3012	17.20	21.51	25.81	87	43.5	6.5955	32.98	39.57
38	19	4.3589	17.44	21.79	26.15	88	44	6.6332	33.17	39.80
39	19.5	4.4159	17.66	22.08	26.50	89	44.5	6.6708	33.35	40.02
40	20	4.4721	17.89	22.36	26.83	90	45	6.7082	33.54	40.25
41	20.5	4.5277	18.11	22.64	27.17	91	45.5	6.7454	33.73	40.47
42	21	4.5826	18.33	22.91	27.50	92	46	6.7823	33.91	40.69
43	21.5	4.6368	18.55	23.18	27.82	93	46.5	6.8191	34.10	40.91
44	22	4.6904	18.76	23.45	28.14	94	47	6.8557	34.28	41.13
45	22.5	4.7434	18.97	23.72	28.46	95	47.5	6.8920	34.46	41.35
46	23	4.7958	19.18	23.98	28.77	96	48	6.9282	34.64	41.57
47	23.5	4.8477	19.39	24.24	29.09	97	48.5	6.9642	34.82	41.79
48	24	4.8990	19.60	24.49	29.39	98	49	7	35	42
49	24.5	4.9497	19.80	24.75	29.70	99	49.5	7.0356	35.18	42.21
50	25	5	20	25	30	100	50	7.0711	35.36	42.43

{217}

TWIST TABLES FOR 3 PLY.

No. of Yarn to be Twisted	No. of Twisted Yarn	Square Root of No. Twisted Yarn	Square Root Multiplied by			No. of Yarn to be Twisted	No. of Twisted Yarn	Square Root of No. Twisted Yarn	Square Root Multiplied by		
			4	5	6				4	5	6
1	.33	.5774	2.31	2.89	3.46	51	17	4.1231	16.49	20.62	24.74
2	.67	.8165	3.27	4.08	4.90	52	17.33	4.1633	16.65	20.82	24.98
3	1	1	4	5	6	53	17.67	4.2032	16.81	21.02	25.22
4	1.33	1.1547	4.62	5.77	6.93	54	18	4.2426	16.97	21.21	25.46
5	1.67	1.2010	5.16	6.45	7.75	55	18.33	4.2817	17.13	21.41	25.69
6	2	1.4142	5.66	7.07	8.49	56	18.67	4.3205	17.28	21.60	25.92
7	2.33	1.5275	6.11	7.64	9.17	57	19	4.3589	17.44	21.79	26.15
8	2.67	1.6330	6.53	8.16	9.80	58	19.33	4.3970	17.59	21.98	26.38
9	3	1.7321	6.93	8.66	10.39	59	19.67	4.4347	17.74	22.17	26.61
10	3.33	1.8257	7.30	9.13	10.95	60	20	4.4721	17.89	22.36	26.83
11	3.67	1.9149	7.66	9.57	11.49	61	20.33	4.5092	18.04	22.55	27.06
12	4	2	8	10	12	62	20.67	4.5461	18.18	22.73	27.28
13	4.33	2.0817	8.33	10.41	12.49	63	21	4.5826	18.33	22.91	27.50
14	4.67	2.1602	8.64	10.80	12.96	64	21.33	4.6188	18.48	23.09	27.71
15	5	2.2361	8.94	11.18	13.42	65	21.67	4.6547	18.62	23.27	27.93
16	5.33	2.3094	9.24	11.55	13.86	66	22	4.6904	18.76	23.45	28.14
17	5.67	2.3805	9.52	11.90	14.28	67	22.33	4.7258	18.90	23.63	28.35
18	6	2.4495	9.80	12.25	14.70	68	22.67	4.7610	19.04	23.80	28.57
19	6.33	2.5160	10.07	12.58	15.10	69	23	4.7958	19.18	23.98	28.77
20	6.67	2.5820	10.33	12.91	15.49	70	23.33	4.8305	19.32	24.15	28.98
21	7	2.6458	10.58	13.23	15.87	71	23.67	4.8648	19.46	24.32	29.19
22	7.33	2.7080	10.83	13.54	16.25	72	24	4.8990	19.60	24.49	29.39
23	7.67	2.7689	11.08	13.84	16.61	73	24.33	4.9329	19.73	24.66	29.60
24	8	2.8284	11.31	14.14	16.97	74	24.67	4.9666	19.87	24.83	29.80
25	8.33	2.8868	11.55	14.43	17.32	75	25	5	20	25	30
26	8.67	2.9439	11.76	14.72	17.66	76	25.33	5.0332	25.17	30.20
27	9	3	12	15	18	77	25.67	5.0662	25.33	30.40
28	9.33	3.0551	12.22	15.28	18.33	78	26	5.0990	25.50	30.59
29	9.67	3.1091	12.44	15.55	18.65	79	26.33	5.1316	25.66	30.79
30	10	3.1623	12.65	15.81	18.97	80	26.67	5.1640	25.82	30.98
31	10.33	3.2145	12.86	16.07	19.29	81	27	5.1962	25.98	31.18
32	10.67	3.2659	13.06	16.33	19.60	82	27.33	5.2281	26.14	31.37
33	11	3.3166	13.27	16.58	19.90	83	27.67	5.2599	26.30	31.56
34	11.33	3.3665	13.47	16.83	20.20	84	28	5.2915	26.46	31.75
35	11.67	3.4157	13.66	17.08	20.49	85	28.33	5.3229	26.61	31.94
36	12	3.4641	13.86	17.32	20.78	86	28.67	5.3541	26.77	32.12
37	12.33	3.5119	14.05	17.56	21.07	87	29	5.3852	26.93	32.31
38	12.67	3.5590	14.24	17.80	21.35	88	29.33	5.4160	27.08	32.50
39	13	3.6056	14.42	18.03	21.63	89	29.67	5.4467	27.23	32.68
40	13.33	3.6515	14.61	18.26	21.91	90	30	5.4772	27.39	32.86
41	13.67	3.6969	14.79	18.48	22.18	91	30.33	5.5076	27.54	33.05
42	14	3.7417	14.97	18.71	22.45	92	30.67	5.5377	27.69	33.23
43	14.33	3.7859	15.14	18.93	22.72	93	31	5.5678	27.84	33.41
44	14.67	3.8297	15.32	19.15	22.98	94	31.33	5.5976	27.99	33.59
45	15	3.8730	15.49	19.36	23.24	95	31.67	5.6273	28.14	33.76
46	15.33	3.9158	15.66	19.58	23.49	96	32	5.6569	28.28	33.94
47	15.67	3.9582	15.83	19.79	23.75	97	32.33	5.6862	28.43	34.12
48	16	4	16	20	24	98	32.67	5.7155	28.58	34.29
49	16.33	4.0415	16.17	20.21	24.25	99	33	5.7446	28.72	34.47
50	16.67	4.0825	16.33	20.41	24.49	100	33.33	5.7735	28.87	34.64

{218}

TWIST TABLES FOR 4 PLY.

No. of Yarn to be Twisted	No. of Twisted Yarn	Square Root of No. Twisted Yarn	Square Root Multiplied by			No. of Yarn to be Twisted	No. of Twisted Yarn	Square Root of No. Twisted Yarn	Square Root Multiplied by		
			4	5	6				4	5	6
1	.25	.5	2	2.5	3	51	12.75	3.5707	14.28	17.85	21.42
2	.50	.7071	2.89	3.54	4.24	52	13	3.6056	14.42	18.08	21.63
3	.75	.8660	3.46	4.33	5.20	53	13.25	3.6401	14.56	18.20	21.84
4	1	1	4	5	6	54	13.50	3.6742	14.70	18.37	22.05
5	1.25	1.1180	4.47	5.59	6.71	55	13.75	3.7081	14.83	18.54	22.25
6	1.50	1.2247	4.90	6.12	7.35	56	14	3.7417	14.97	18.71	22.45
7	1.75	1.3229	5.29	6.61	7.94	57	14.25	3.7749	15.10	18.87	22.65
8	2	1.4142	5.66	7.07	8.49	58	14.50	3.8079	15.23	19.04	22.85
9	2.25	1.5	6	7.5	9	59	14.75	3.8406	15.36	19.20	23.04
10	2.50	1.5811	6.32	7.91	9.49	60	15	3.8730	15.49	19.37	23.24
11	2.75	1.6583	6.63	8.29	9.95	61	15.25	3.9051	15.62	19.53	23.43
12	3	1.7321	6.93	8.66	10.39	62	15.50	3.9370	15.75	19.69	23.62
13	3.25	1.8028	7.21	9.01	10.82	63	15.75	3.9686	15.88	19.84	23.81
14	3.50	1.8708	7.48	9.35	11.22	64	16	4	16	20	24
15	3.75	1.9365	7.75	9.68	11.62	65	16.25	4.0311	16.12	20.16	24.19
16	4	2	8	10	12	66	16.50	4.0620	16.25	20.31	24.37
17	4.25	2.0616	8.25	10.31	12.37	67	16.75	4.0927	16.37	20.46	24.56
18	4.50	2.1213	8.40	10.61	12.73	68	17	4.1231	16.49	20.62	24.74
19	4.75	2.1794	8.72	10.90	13.08	69	17.25	4.1533	16.61	20.77	24.92
20	5	2.2361	8.94	11.18	13.42	70	17.50	4.1833	16.73	20.92	25.10
21	5.25	2.2913	9.17	11.46	13.75	71	17.75	4.2130	16.85	21.07	25.28
22	5.50	2.3452	9.38	11.73	14.07	72	18	4.2426	16.97	21.21	25.46
23	5.75	2.3979	9.59	11.99	14.39	73	18.25	4.2720	17.09	21.36	25.63
24	6	2.4495	9.80	12.25	14.70	74	18.50	4.3012	17.20	21.51	25.81
25	6.25	2.5	10	12.5	15	75	18.75	4.3301	17.32	21.65	25.98
26	6.50	2.5495	10.20	12.75	15.30	76	19	4.3589	21.79	26.15
27	6.75	2.5981	10.39	12.99	15.59	77	19.25	4.3875	21.94	26.32
28	7	2.6458	10.58	13.23	15.87	78	19.50	4.4159	22.08	26.50
29	7.25	2.6926	10.77	13.46	16.16	79	19.75	4.4441	22.22	26.66
30	7.50	2.7386	10.95	13.69	16.43	80	20	4.4721	22.36	26.83
31	7.75	2.7839	11.14	13.92	16.70	81	20.25	4.5	22.5	27
32	8	2.8284	11.31	14.14	16.97	82	20.50	4.5277	22.64	27.17
33	8.25	2.8723	11.49	14.36	17.23	83	20.75	4.5552	22.78	27.33
34	8.50	2.9155	11.66	14.58	17.49	84	21	4.5826	22.91	27.50
35	8.75	2.9580	11.83	14.79	17.75	85	21.25	4.6098	23.05	27.66
36	9	3	12	15	18	86	21.50	4.6368	23.18	27.82
37	9.25	3.0414	12.17	15.21	18.25	87	21.75	4.6637	23.32	27.98
38	9.50	3.0822	12.33	15.41	18.49	88	22	4.6904	23.45	28.14
39	9.75	3.1225	12.49	15.61	18.73	89	22.25	4.7170	23.58	28.30
40	10	3.1623	12.65	15.81	18.97	90	22.50	4.7434	23.72	28.46
41	10.25	3.2016	12.81	16.01	19.21	91	22.75	4.7697	23.85	28.62
42	10.50	3.2404	12.96	16.20	19.44	92	23	4.7958	23.98	28.77
43	10.75	3.2787	13.11	16.39	19.67	93	23.25	4.8218	24.11	28.93
44	11	3.3166	13.27	16.58	19.90	94	23.50	4.8477	24.24	29.09
45	11.25	3.3541	13.42	16.77	20.12	95	23.75	4.8734	24.37	29.24
46	11.50	3.3912	13.56	16.96	20.35	96	24	4.8990	24.49	29.39
47	11.75	3.4278	13.71	17.14	20.57	97	24.25	4.9244	24.62	29.55
48	12	3.4641	13.86	17.32	20.78	98	24.50	4.9497	24.75	29.70
49	12.25	3.5	14	17.5	21	99	24.75	4.9749	24.87	29.85
50	12.50	3.5355	14.14	17.68	21.21	100	25	5	25	30

{219}

TWIST TABLES FOR 5 PLY.

No. of Yarn to be Twisted	No. of Twisted Yarn	Square Root of No. of Twisted Yarn	Square Root Multiplied by			No. of Yarn to be Twisted	No. of Twisted Yarn	Square Root of No. of Twisted Yarn	Square Root Multiplied by		
			4	5	6				4	5	6
1	.2	.4472	1.70	2.24	2.68	51	10.2	3.1987	12.77	15.97	19.16
2	.4	.6325	2.53	3.16	3.79	52	10.4	3.2249	12.90	16.12	19.35
3	.6	.7746	3.10	3.87	4.65	53	10.6	3.2558	13.02	16.28	19.53
4	.8	.8944	3.58	4.47	5.37	54	10.8	3.2903	13.15	16.43	19.72
5	1	1	4	5	6	55	11	3.3166	13.27	16.58	19.90
6	1.2	1.0954	4.38	5.48	6.57	56	11.2	3.3466	13.39	16.73	20.08
7	1.4	1.1892	4.73	5.92	7.10	57	11.4	3.3764	13.51	16.88	20.26
8	1.6	1.2649	5.06	6.32	7.59	58	11.6	3.4059	13.62	17.03	20.44
9	1.8	1.3416	5.37	6.71	8.05	59	11.8	3.4351	13.74	17.18	20.61
10	2	1.4142	5.66	7.07	8.49	60	12	3.4641	13.86	17.32	20.78
11	2.2	1.4882	5.93	7.42	8.90	61	12.2	3.4928	13.97	17.46	20.96
12	2.4	1.5492	6.20	7.75	9.30	62	12.4	3.5214	14.09	17.61	21.13
13	2.6	1.6125	6.45	8.06	9.67	63	12.6	3.5496	14.20	17.75	21.30
14	2.8	1.6733	6.69	8.37	10.04	64	12.8	3.5777	14.31	17.89	21.47
15	3	1.7321	6.93	8.66	10.39	65	13	3.6056	14.42	18.03	21.63
16	3.2	1.7889	7.16	8.95	10.73	66	13.2	3.6332	14.53	18.17	21.80
17	3.4	1.8439	7.38	9.22	11.06	67	13.4	3.6606	14.64	18.30	21.96
18	3.6	1.8974	7.59	9.49	11.38	68	13.6	3.6878	14.75	18.44	22.13
19	3.8	1.9494	7.80	9.75	11.70	69	13.8	3.7148	14.86	18.56	22.29
20	4	2	8	10	12	70	14	3.7417	14.97	18.71	22.45
21	4.2	2.0494	8.20	10.25	12.30	71	14.2	3.6783	15.07	18.84	22.61
22	4.4	2.0976	8.39	10.49	12.59	72	14.4	3.7348	15.18	18.97	22.77
23	4.6	2.1448	8.58	10.72	12.87	73	14.6	3.8210	15.28	19.10	22.93
24	4.8	2.1909	8.76	10.95	13.15	74	14.8	3.8471	15.38	19.24	23.08
25	5	2.2361	8.94	11.18	13.42	75	15	3.8730	15.49	19.37	23.24
26	5.2	2.2804	9.12	11.40	13.68	76	15.2	3.8987	19.49	23.39
27	5.4	2.3238	9.30	11.62	13.94	77	15.4	3.9243	19.62	23.55
28	5.6	2.3664	9.47	11.83	14.20	78	15.6	3.9497	19.75	23.70
29	5.8	2.4083	9.63	12.04	14.45	79	15.8	3.9749	19.87	23.85
30	6	2.4495	9.80	12.25	14.70	80	16	4	20	24
31	6.2	2.4900	9.96	12.45	14.94	81	16.2	4.0249	20.12	24.15
32	6.4	2.5298	10.12	12.65	15.18	82	16.4	4.0497	20.25	24.30
33	6.6	2.5690	10.28	12.85	15.41	83	16.6	4.0743	20.37	24.45
34	6.8	2.6077	10.43	13.04	15.65	84	16.8	4.0988	20.49	24.59
35	7	2.6458	10.58	13.23	15.87	85	17	4.1231	20.62	24.74
36	7.2	2.6833	10.73	13.42	16.10	86	17.2	4.1473	20.74	24.88
37	7.4	2.7203	10.88	13.60	16.32	87	17.4	4.1713	20.86	25.03
38	7.6	2.7568	11.03	13.78	16.54	88	17.6	4.1952	20.98	25.17
39	7.8	2.7928	11.17	13.96	16.76	89	17.8	4.2190	21.10	25.31
40	8	2.8284	11.31	14.14	16.97	90	18	4.2426	21.21	25.46
41	8.2	2.8635	11.45	14.32	17.18	91	18.2	4.2661	21.33	25.60
42	8.4	2.8983	11.59	14.49	17.39	92	18.4	4.2895	21.45	25.74
43	8.6	2.9326	11.73	14.66	17.60	93	18.6	4.3128	21.56	25.88
44	8.8	2.9665	11.87	14.83	17.80	94	18.8	4.3359	21.68	26.02
45	9	3	12	15	18	95	19	4.3589	21.79	26.15
46	9.2	3.0332	12.13	15.17	18.20	96	19.2	4.3818	21.91	26.29
47	9.4	3.0659	12.26	15.33	18.40	97	19.4	4.4045	22.02	26.43
48	9.6	3.0984	12.39	15.49	18.59	98	19.6	4.4272	22.14	26.50
49	9.8	3.1305	12.52	15.65	18.78	99	19.8	4.4497	22.25	26.70
50	10	3.1623	12.65	15.81	18.97	100	20	4.4721	22.36	26.88

{220}

TWIST TABLES FOR 6 PLY.

No. of Yarn to be Twisted	No. of Twisted Yarn	Square Root of No. Twisted Yarn	Square Root Multiplied by			No. of Yarn to be Twisted	No. of Twisted Yarn	Square Root of No. Twisted Yarn	Square Root Multiplied by		
			4	5	6				4	5	6
1	.17	.4082	1.63	2.04	2.45	51	8.50	2.9155	11.66	14.58	17.49
2	.33	.5774	2.31	2.89	3.46	52	8.67	2.9439	11.78	14.72	17.66
3	.50	.7071	2.83	3.54	4.24	53	8.83	2.9721	11.89	14.86	17.83
4	.67	.8165	3.27	4.08	4.90	54	9	3	12	15	18
5	.83	.9129	3.65	4.56	5.48	55	9.17	3.0277	12.11	15.14	18.17
6	1	1	4	5	6	56	9.33	3.0551	12.22	15.28	18.33
7	1.17	1.0801	4.32	5.40	6.48	57	9.50	3.0822	12.33	15.41	18.49
8	1.33	1.1547	4.62	5.77	6.93	58	9.67	3.1091	12.44	15.55	18.65
9	1.50	1.2247	4.90	6.12	7.35	59	9.83	3.1358	12.54	15.68	18.81
10	1.67	1.2910	5.16	6.45	7.75	60	10	3.1623	12.65	15.81	18.97
11	1.83	1.3540	5.42	6.77	8.12	61	10.17	3.1885	12.75	15.94	19.13
12	2	1.4142	5.66	7.07	8.40	62	10.33	3.2145	12.86	16.07	19.29
13	2.17	1.4720	5.89	7.36	8.83	63	10.50	3.2404	12.96	16.20	19.44
14	2.33	1.5275	6.11	7.64	9.17	64	10.67	3.2659	13.06	16.33	19.60
15	2.50	1.5811	6.32	7.91	9.49	65	10.83	3.2914	13.17	16.46	19.75
16	2.67	1.6330	6.53	8.16	9.80	66	11	3.3166	13.27	16.58	19.90
17	2.83	1.6833	6.73	8.42	10.10	67	11.17	3.3417	13.37	16.71	20.05
18	3	1.7321	6.93	8.66	10.39	68	11.33	3.3665	13.47	16.83	20.20
19	3.17	1.7795	7.12	8.90	10.68	69	11.50	3.3912	13.56	16.96	20.35
20	3.33	1.8257	7.30	9.13	10.95	70	11.67	3.4157	13.66	17.08	20.49
21	3.50	1.8708	7.48	9.35	11.22	71	11.83	3.4400	13.76	17.20	20.64
22	3.67	1.9149	7.66	9.57	11.49	72	12	3.4641	13.86	17.32	20.78
23	3.83	1.9579	7.83	9.79	11.75	73	12.17	3.4881	13.95	17.44	20.93
24	4	2	8	10	12	74	12.33	3.5119	14.05	17.56	21.07
25	4.17	2.0412	8.16	10.21	12.25	75	12.50	3.5355	14.14	17.68	21.21
26	4.33	2.0817	8.33	10.41	12.49	76	12.67	3.5590	14.24	17.80	21.35
27	4.50	2.1213	8.49	10.61	12.73	77	12.83	3.5824	14.33	17.91	21.49
28	4.67	2.1602	8.64	10.80	12.96	78	13	3.6056	14.42	18.03	21.63
29	4.83	2.1985	8.79	10.99	13.19	79	13.17	3.6286	14.51	18.14	21.77
30	5	2.2361	8.94	11.18	13.42	80	13.33	3.6515	14.60	18.25	21.91
31	5.17	2.2730	9.09	11.37	13.64	81	13.50	3.6742	14.69	18.37	22.05
32	5.33	2.3094	9.24	11.55	13.86	82	13.67	3.6969	14.78	18.48	22.18
33	5.50	2.3452	9.38	11.73	14.07	83	13.83	3.7192	14.87	18.60	22.32
34	5.67	2.3805	9.52	11.90	14.28	84	14	3.7417	14.96	18.71	22.45
35	5.83	2.4152	9.66	12.08	14.49	85	14.17	3.7639	15.05	18.82	22.58
36	6	2.4495	9.80	12.25	14.70	86	14.33	3.7859	15.14	18.93	22.72
37	6.17	2.4833	9.93	12.42	14.90	87	14.50	3.8079	15.23	19.04	22.85
38	6.33	2.5166	10.07	12.58	15.10	88	14.67	3.8297	15.32	19.15	22.98
39	6.50	2.5495	10.20	12.75	15.30	89	14.83	3.8514	15.41	19.26	23.11
40	6.67	2.5820	10.33	12.91	15.49	90	15	3.8730	15.50	19.36	23.24
41	6.83	2.6141	10.46	13.07	15.68	91	15.17	3.8944	15.59	19.47	23.37
42	7	2.6458	10.58	13.23	15.87	92	15.33	3.9158	15.68	19.58	23.49
43	7.17	2.6771	10.71	13.39	16.06	93	15.50	3.9370	15.77	19.69	23.62
44	7.33	2.7080	10.83	13.54	16.25	94	15.67	3.9582	15.86	19.79	23.75
45	7.50	2.7386	10.95	13.69	16.43	95	15.83	3.9791	15.95	19.90	23.87
46	7.67	2.7689	11.08	13.84	16.61	96	16	4	20	24	24
47	7.83	2.7988	11.20	13.99	16.79	97	16.17	4.0208	20.10	24.12	24
48	8	2.8284	11.31	14.14	16.97	98	16.33	4.0415	20.21	24.25	24
49	8.17	2.8577	11.43	14.29	17.15	99	16.50	4.0620	20.31	24.37	24
50	8.33	2.8868	11.55	14.43	17.32	100	16.67	4.0825	20.41	24.49	24

{221}

{222}

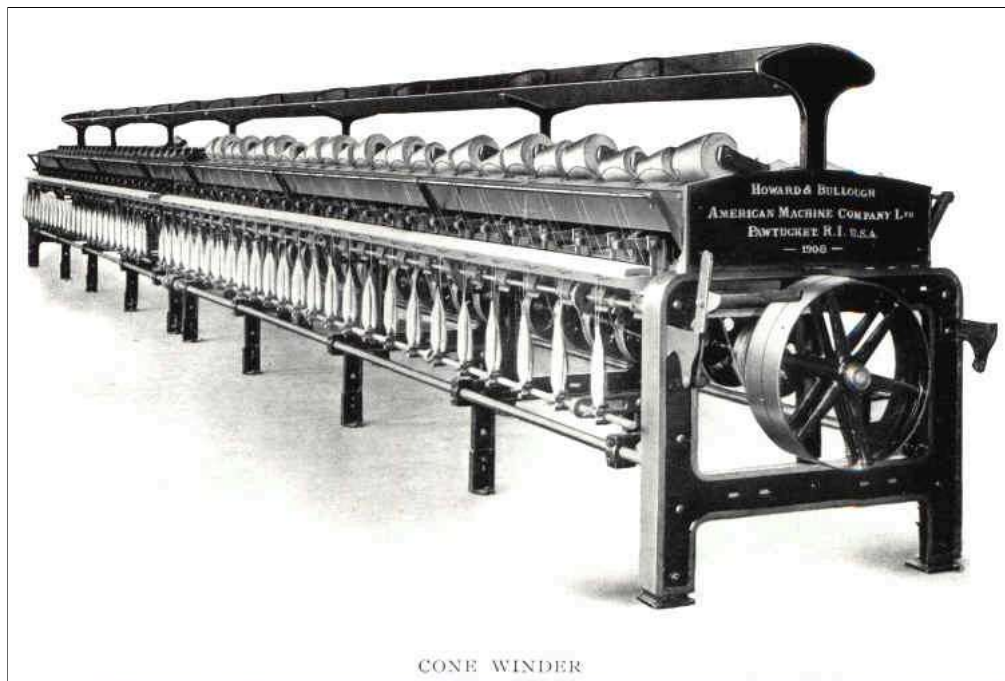

CONE WINDER
CONE WINDER

CONE AND TUBE WINDERS.

Although these machines are adapted to the winding of all kinds of yarns, they are especially good for soft hosiery and underwear yarns which should be handled so as to retain their full strength and elasticity.

OPEN WIND—This feature of our machine, together with its general improved construction, enables it to wind the most delicate yarns. The open wind with its irregular coils is of great advantage, as stretching of the yarn is avoided and it unwinds freely in the knitting process.

CONE AND PARALLEL WIND—These machines are built for winding either cones or parallel tubes, from cops, bobbins, spools or skeins.

STOP MOTIONS—These are applied to all machines. The Detector Holders and Drop Wires are supplied for one or more ply, as required. When a thread breaks, the individual drum stops, thus preventing waste or single. The Stop Motions are quick and positive, and the piecing up is very easily done.

FRAMING AND CONSTRUCTION—The Winders are strong and durable. No wood is used in their construction, except for the top shelves and Friction Boards. All gearing is cut. The Casing-off Plates on each side are hinged, which facilitates cleaning.

UNIFORM TENSION—The conical and parallel Mandrels are driven by friction from the drums, and consequently the increase in diameter of the cones or tubes does not alter the tension on the yarn.

IMPROVED MANDRELS—These fit firmly in the paper cones at both ends. The cones are very easily removed, and although they may vary in size or shape, any irregularities are taken care of by the Mandrels.

IMPROVED REVERSING MOTION—The durability of Winders and the uniformity of the winding depends {224} to a great extent on the accuracy and wearing qualities of the Reversing Motion. The cam and bowl in this motion are of hardened steel, and the cam runs in oil.

Our Motion gives an instantaneous reversal, and prevents the throwing over of the yarn at the ends, ensuring a perfectly shaped cone or parallel Tube.

ADJUSTABLE TRAVERSE—The length of the traverse can be adjusted from 4 in. to 6 in. by a very simple method.

AVAILABLE SPEED TRAVERSE—By means of a change gear on the Main Driving Shaft, the ratio of the speed of the traverse to the speed of the drum can be altered. A ratio which is best suited to coarse yarn is not the best for fine yarn. The work which these machines are called upon to do may vary from winding very coarse ply yarns to fine single yarns, and a variable speed traverse is of advantage.

DRIVING PULLEYS—These are 18 in. dia., 2-1/2 in. face, Tight and Loose, and usually make 100 to 125 revs., according to the class of work.

PRODUCTION—Based on 125 revs. of Driving Pulleys, with 20 per cent allowance for stops, the production per drum per week of 60 hours figures 500 hanks (hanks/number of yarn = lbs.)

FLOOR PLAN OF CONE WINDER

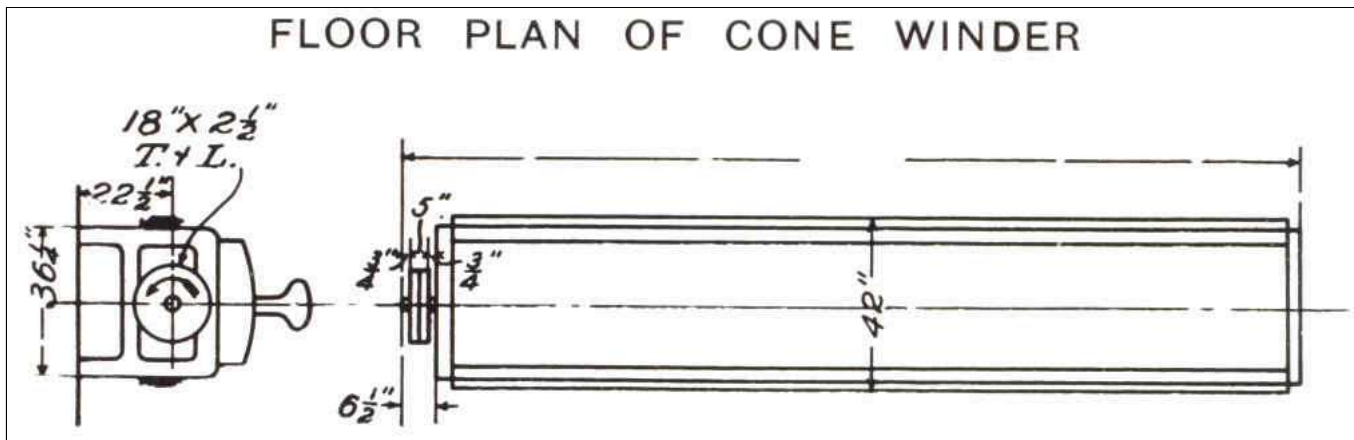

Machines are 42 in. wide and are usually built with 100 drums, 36 ft. 8-1/2 in. over all (including driving pulleys) but other lengths can be made. Deduct 8-1/4 in. for each two drums less than 100.

{225}

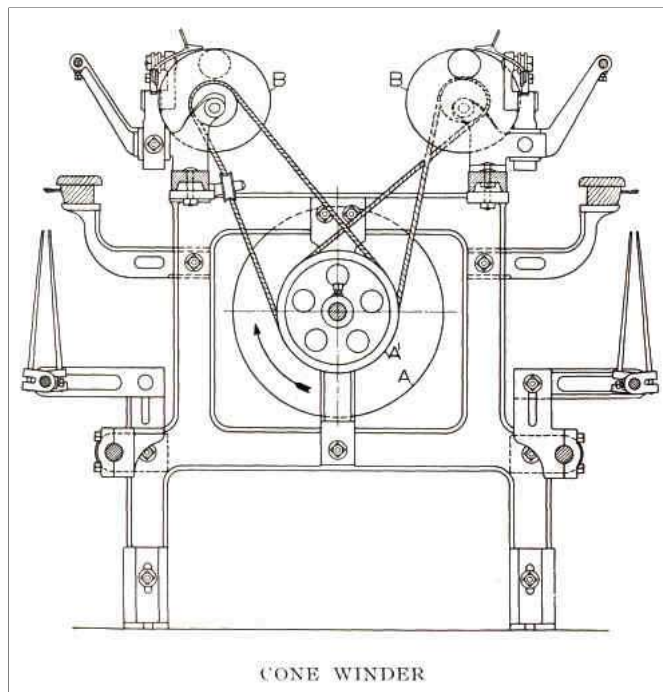

CONE WINDER
CONE WINDER

ALPHABETICAL REFERENCES TO DRAWING

- A Driving Pulley, 18 in. dia. x 2-1/2 in. face. Usual speed, 100 to 125 r. p. m.
- A¹ Cone Driving Double Band Pulley.
- B Cone.

NOTE—One rev. of Driving Shaft equals 2.76 revs. of Cone.

{226}

WARPERS.

One 54-in. Cylinder Warper (with large dia. Cylinder) occupies a space of 7 ft. x 3 ft. 6 in. with 24-in. beam head.

The floor space of creels varies considerably. An ordinary Warper with creel requires a space of about 8 ft. x 13 to 14 ft.

Driving Pulleys 10 in. x 2 in.

Cylinders of Warpors are run from 30 to 40 revs. per minute, depending on the class of work.

We give below production table based on 36 revs. of Cylinder (Pulleys 196 revs.) per minute. In this table 33 per cent. has been deducted for stoppages.

No. of Ends	260	300	320	340	360	380	410	440
No. of Varn	Pounds warped in sixty hours							
8	5,015	5,785	6,171	6,557	6,943	7,329	7,907	8,485
10	4,011	4,629	4,937	5,246	5,555	5,863	6,325	6,789
12	3,343	3,857	4,181	4,372	4,629	4,885	5,271	5,657
14	2,865	3,305	3,527	3,747	3,967	4,188	4,519	4,849
16	2,507	2,898	3,085	3,279	3,471	3,664	3,953	4,243
18	2,229	2,571	2,743	2,915	3,085	3,257	3,515	3,771
20	2,005	2,315	2,468	2,623	2,777	2,931	3,163	3,395
22	1,823	2,104	2,244	2,385	2,525	2,665	2,875	3,085
24	1,671	1,925	2,057	2,185	2,315	2,443	2,636	2,829
26	1,543	1,780	1,899	2,017	2,136	2,255	2,433	2,611
28	1,433	1,653	1,763	1,873	1,983	2,094	2,259	2,425
29	1,383	1,596	1,703	1,809	1,915	2,021	2,181	2,341
30	1,337	1,543	1,645	1,749	1,851	1,955	2,109	2,263
32	1,253	1,447	1,543	1,639	1,736	1,832	1,977	2,121
34	1,180	1,361	1,452	1,543	1,633	1,725	1,861	1,997
36	1,115	1,285	1,371	1,457	1,543	1,629	1,757	1,885
38	1,056	1,219	1,299	1,380	1,461	1,543	1,665	1,787
40	1,003	1,157	1,235	1,311	1,389	1,465	1,581	1,697
44	912	1,052	1,123	1,192	1,262	1,332	1,437	1,543
50	806	925	987	1,049	1,111	1,171	1,265	1,357

{227}

{228}

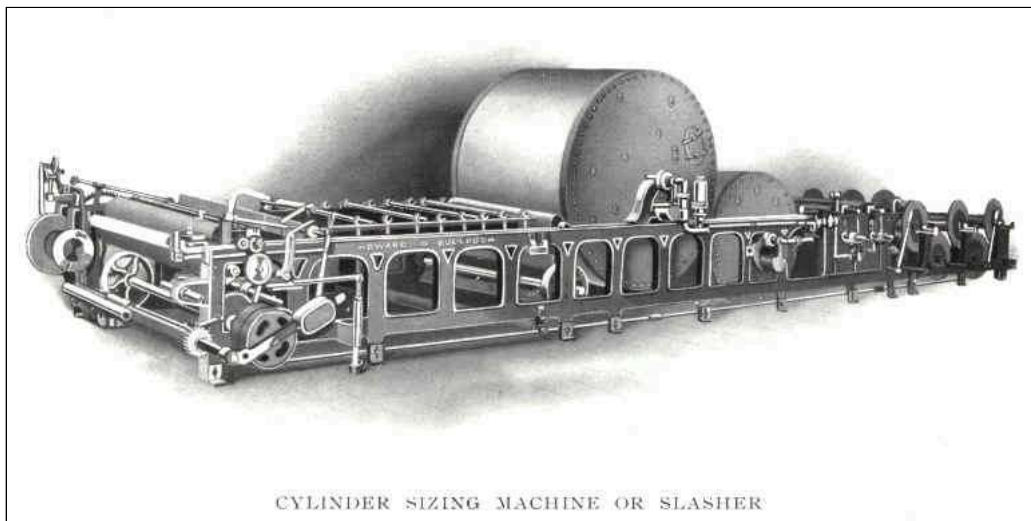

CYLINDER SIZING MACHINE OR SLASHER
CYLINDER SIZING MACHINE OR SLASHER

{229}

SLASHERS.

The Slasher System of Sizing was invented by Mr. James Bullough, and Slashers were first made and put on the market by Howard & Bullough, Ltd.

The advent of the Slasher, dispensing as it did with the old systems of Sizing, is recognized as one of the greatest inventions of the age. Probably no other invention was ever taken up and supplanted other systems with such rapidity as

that of the Slasher, in every cotton manufacturing country. Although Slashers are now made by others, the Howard & Bullough machine still keeps the lead, and improvements are being continually added.

NEW PATTERNS—The machines are now made from new patterns with extra heavy framing, with broad flanges, planed edges, and milled doubled-flanged joints, giving great strength and solidity. All seatings, cross-rails, principal brackets and fixings are planed or milled.

HEADSTOCKS—These are made in three lengths, Short (8 ft. 6 in.), Medium (10 ft. 4 in.) and Long (12 ft. 2 in.), and are complete with Fan, Conducting Rollers, Polished Dividing Rods, quick and accurate Yarn Marker, Expanding and Contracting Comb, Spring Bearings for preventing the breaking of yarn when starting the machine, Triple Speed Change Gears, Slow Motion arrangement, Side Shaft, and Gearing to Copper Size Rollers, Patent Yarn Beam Friction and Patent Revolving Yarn Beam Presser.

PATENT YARN BEAM FRICTION—With four frictional surfaces. These Frictions have more than double the friction surface of the older styles, and give considerably more power and are proving the most efficient Frictions ever invented.

SLOW MOTION DRIVING—This enables the Slasher to be run at a very slow speed, instead of being entirely stopped whilst doffing, etc., thus preventing the burning or spoiling of yarn whilst under the squeezing rollers in the size box.
{230}

COPPER CYLINDERS—Made from best Copper Sheets well and evenly rolled by machinery, so as to give a perfectly smooth drying surface, with Ends or Heads made of Steel plates. Cylinder Shafts run on Anti-Friction Bowls, and are provided with Pressure Gauge, Safety and Reducing Valves, and Steam Traps.

SIZE BOX—With two Heavy Seamless Copper Rollers, with Brass Glands and Brass Bushes. The Ends of these Rollers run in Brass Steps in Pedestals supported by Tables which are cast to the outside of the Size Box.

Size Box also contains perforated Copper Boiling Pipe, Seamless Copper Immersion Roller, with adjustable Racks and Motion, Brass and Tin Conducting Rollers, and Brass Taps.

CREELS—These are usually made for 6 Beams, but are made for more if required, and have Adjustable Bearings. Three sizes are made, 22-3/8 in., 25-1/2 in. and 27 in. between centers. The latter for Beam Heads up to 26 in. dia.

We also apply, when ordered, any of the following:

Patent Traversing Yarn Beam Presser.

Patent Expanding Double Yarn Beam Presser.

Patent Yarn Tension Arrangement to Size Box for enabling the size to better penetrate the Yarns.

Positive Driving Arrangement to Cylinders for Fine Yarns or small number of ends.

Extra Carrying Rolls and Stands.

PRODUCTION—One Slasher will supply from 150 to 600 Looms, according to the class of work; about 300 is the average.

DRIVING PULLEYS—Are on Right Hand side of Head-stock (when facing same), 13 in. dia., 3 in. face, T. & L. Slow Motion Pulley is 1 in. face, making 7 in. in width for the three Pulleys.

SPEEDS—170 to 210 R. P. M.

{231}

FLOOR SPACE—Dimensions of Standard machines with Short Headstock (8 ft. 6 in.) and 6-Beam Creel, 23-1/2 in. or 27 in. centers, the latter for Beam Heads up to 26 in. dia. ; 9/8 wide, for Warper Beams 54 in. wide between Heads, Drying Surface of Cylinders, 56-1/2 in.

6 ft. dia. Cylinder 31 ft. 0 in. x 8 ft. 6 in. (Width is 8 ft. 11 in. over extreme projections in Headstock when Cannon Shaft is extended.)

7 ft. dia. Cylinder 33 ft. 4 in. x 8 ft. 6 in.

66 in. and 40 in. dia. Cylinders 33 ft. 4 in. x 8 ft. 6 in.

6 ft. and 4 ft. dia. Cylinders 33 ft. 10 in. x 8 ft. 6 in.

7 ft. and 4 ft. dia. Cylinders 34 ft. 10 in. x 8 ft. 6 in.

7 ft. and 5 ft. dia. Cylinders 37 ft. 10 in. x 8 ft. 6 in.

Add for each additional two Beams in Creel, 3 ft. 4-1/2 in.

Add for Medium Headstock 1 ft. 10 in.

Add for Long Headstock 3 ft. 8 in.

LOOM BEAMS—Slashers 9/8 wide, as described above, will take Loom Beams up to 64 in. long over all, or up to 70 in. by using Cranked Cannon Shaft Brackets.

WIDER SLASHERS—These are made up to 12/4 wide, for widths of yarn as follows:

9/8	6/4	7/4	8/4	9/4	10/4	11/4	12/4
54 in.	60 in.	66 in.	72 in.	78 in.	84 in.	90 in.	96 in.

Add to the width of machines, as given above, 6 in. for each extra width over 9/8.

SPECIAL MACHINES—Are made with Extra Wide or Extra Long Heads and many other attachments for Special Work, also with AIR DRYING instead of Cylinders.

{232}

APPROXIMATE SHIPPING WEIGHTS OF MACHINES

	Pounds
Hopper Bale Opener	5,000
Self-feeding Opener	6,000 to 6,500
Single Beater Breaker Lapper	8,500 to 9,500
Self-feeding Opener and Single Beater Breaker	15,000 to 16,000
Single Beater Intermediate or Finisher	8,500
Double Beater Intermediate or Finisher	13,000
Revolving Flat Card	7,000
Drawing Frame, per delivery	700
Slubbing Frame, 60 spdls., 12 in. x 6 in.	9,250
Intermediate Frame, 96 spdls., 10 in. x 5 in.	10,000
Roving Frame, 144 spdls., 8 in. x 4 in.	11,500
Roving Frame, 160 spdls., 7 in. x 3-1/2 in.	11,250
Jack Frame, 184 spdls., 6 in. x 3 in.	11,250
Spinning Frame, 224 spdls., 2-3/4 in. Ga.	6,250
Spinning Frame, 204 spdls., 3 in. Ga.	6,250
Spinning Frame, 192 spdls., 3-1/4 in. Ga.	6,250
Twister, 220 spdls., 3 in. Ga.	7,000
Twister, 192 spdls., 3-1/4 in. Ga.	7,300
Twister, 160 spdls., 4 in. Ga.	6,800
Twister, 132 spdls., 5 in. Ga.	6,700
Cone Winder, 100 Drums	7,500

{233}

ENGLISH WEIGHTS AND MEASURES OF COTTON YARN.

24 Grains = 1 Pennyweight (Dwt. Troy).

437.5 Grains = 1 Ounce (Avoirdupois).

16 oz. = 7,000 Grains = 1 Pound (Avoirdupois).

1-1/2 Yards = 54 in. = 1 thread or circumference of Cotton Reel.

120 Yards = 80 threads = 1 Skein.

840 Yards = 560 threads = 7 skeins = 1 Hank.

The number of Hanks in 1 lb. is the number of the yarn.

7,000 grains (1 lb.) divided by the weight in grains of 1 Hank (840 Yards) = the number of yarn.

It is unnecessary and inconvenient to measure and weigh a full hank, and a lesser number of yards are usually taken. 120 yards for yarn, and 12 yards for Roving are common, and the Dividends for these are given in the following table.

DIVIDEND TABLE

Yards	Dividends
1	8.33
2	16.66
3	25.00
4	33.33
5	41.66
6	50.00
7	58.33
8	66.66
9	75.00
10	83.33
12	100.00
30	250.00
60	500.00
120	1000.00
840	7600.00

RULES

Divide 7,000 (Grains in 1 lb.) by 840 (yards in 1 Hank) = dividend for 1 yd., 8.33.

Dividend/by weight in grains = Hank.

Dividend/by Hank = Weight in Grains.

EXAMPLES—If 1 yard of Card Sliver weighs 55 Grains, what Hank is it? Divide the dividend for 1 yard (8.33) by 55 = .151 Hank.

What should 120 yds. of No. 25s yarn weigh? Divide the dividend for 120 yards (1,000) by 25 = 40 grains.

{234}

GENERAL RULES WITH EXAMPLES.

TO FIND THE DRAFT BETWEEN TWO ROLLS.

Rule:

$$\frac{\text{Dia. of Front Roll} \times \text{Teeth on Driving Gears}}{\text{Dia. of Back Roll} \times \text{Teeth on Driven Gears}} = \text{Draft.}$$

Example:

On a Spinning Frame the front roll is 1 inch dia. and the back roll $\frac{7}{8}$ inch dia. Back Roll Gear, 89 T. Draft Change Gear, 45 T. Crown Gear 72 T and Front Roll Gear, 27 T.

$$\frac{8 (1 \text{ in.} = \frac{8}{8} \text{ in.}) \times 89 \times 72}{7 (\frac{7}{8} \text{ in.}) \times 45 \times 27} = 6.03 \text{ Draft.}$$

RULES FOR USE WHEN CHANGING FROM ONE HANK OR NUMBER TO ANOTHER.

DRAFT CALCULATIONS.

Rule when changing weight:

$$\frac{\text{Present Draft Gear} \times \text{Required Weight}}{\text{Present Weight}} = \text{Required Draft Gear.}$$

Example:

On a Drawing Frame it is desired to change from 50 to 60 grain sliver, and the Draft Change Gear on the machine has 55 T.

$$\frac{55 \times 60}{50} = 66 \text{ T.} = \text{Required Draft Gear.}$$

Rule when changing hank or number of yarn:

$$\frac{\text{Present Draft Gear} \times \text{Present Hank}}{\text{Required Hank}} = \text{Required Draft Gear.}$$

Example:

On a Speeder it is desired to change from 3.20 hank to 4.80 hank and the Draft Change Gear on the Frame has 57 T.

$$\frac{57 \times 3.20}{4.80} = 38 \text{ T. on Required Draft Gear.}$$

{235}

Rule when changing Draft:

$$\frac{\text{Present Draft Gear} \times \text{Present Draft}}{\text{Required Draft}} = \frac{\text{Required Draft}}{\text{Gear}}$$

Example:

On a Spinning Frame it is desired to change from 8.00 to 11.00 Draft, and the Present Draft Change Gear has 55 T.

$$\frac{55 \times 8.00}{11.00} = 40 \text{ T. on Required Draft Gear.}$$

TWIST CALCULATIONS.

Rule when changing hank or number of yarn:

$$\frac{\text{Present Twist Gear} \times \text{sq. root of Present Hank}}{\text{Sq. root of Required Hank}} = \frac{\text{Required Twist Gear}}{\text{Twist Gear}}$$

Example:

On a Speeder it is desired to change from 4.00 to 5.60 hank and the Present Twist Change Gear has 38 T. Sq. root of 4.00=2.000. Sq. root of 5.60=2.366.

$$\frac{38 \times 2.000}{2.366} = 32 \text{ T. on Required Twist Gear.}$$

Rule when changing Twist per Inch:

$$\frac{\text{Present Twist Gear} \times \text{Present Twist}}{\text{Required Twist}} = \frac{\text{Required Twist}}{\text{Gear}}$$

Example:

On a Twister it is desired to change from 10.70 turns twist per inch to 15.70 and the present Twist Change Gear has 44 T.

$$\frac{44 \times 10.70}{15.70} = 30 \text{ T. on Required Twist Gear.}$$

RATCHET OR TENSION CALCULATIONS.

Rule when changing hank:

$$\frac{\text{Present Ratchet Gear} \times \text{sq. root of Required Hank}}{\text{Sq. root of Present Hank}} = \frac{\text{Required Ratchet Gear}}{\text{Gear}}$$

{236}

Example:

On a Speeder it is desired to change from 1.00 hank to 1.44 hank and the Present Ratchet Gear has 10 T. Sq. root of 1.44 = 1.20. Sq. root of 1.00 = 1.00.

$$\frac{10 \times 1.20}{1.00} = 12 \text{ T. on Required Ratchet Gear.}$$

LAY CALCULATIONS.

Rule when changing hank:

$$\frac{\text{Present Lay Gear} \times \text{sq. root of Present Hank}}{\text{Sq. root of Required Hank}} = \frac{\text{Required Lay Gear}}{\text{Lay Gear}}$$

Example:

On a Speeder it is desired to change from 3.60 hank to 4.50 hank and the present Lay Change Gear has 25 T. Sq. root of 3.60 = 1.897. Sq. root of 4.50 = 2.121.

$$\frac{25 \times 1.897}{2.121} = 22 \text{ T. on Required Lay Gear}$$

{237}

CLASSIFICATION OF COTTON ADOPTED BY THE NEW YORK COTTON EXCHANGE.

QUARTER GRADES IN USE AFTER MARCH 10, 1910.

Grades

Fair.
 Strict Middling Fair.
 Middling Fair.

 Strict Good Middling.

 Good Middling.

 Strict Middling.

 Middling (Basis).
 Strict Low Middling.

 Low Middling.
 Strict Good Ordinary.
 Good Ordinary.
 Strict Good Middling Tinged.
 Good Middling Tinged.
 Strict Middling Tinged.
 Middling Tinged.
 Strict Low Middling Tinged.
 Low Middling Tinged.
 Middling Stained.

{238}

Quarter Grades

Barely Middling Fair.

 Fully Good Middling.

 Barely Good Middling.

 Barely Middling.

 Fully Low Middling.

APPROXIMATE POWER REQUIRED BY COTTON MACHINERY.

	Horse-power
Hopper Bale Opener	3
Hopper Feeder	1-1/2
Self-feeding Opener	3
Single Beater Breaker Lapper, with Cage Section	6
Single Beater Breaker Lapper, with Gauge Box and Condenser 7-1/2	
Combined Self-feeding Opener and Single Beater Breaker Lapper	9
Single Beater Intermediate or Finisher Lapper	4
Two Beater Intermediate or Finisher Lapper	7-1/2
Thread Extractor with Condenser	1-1/2
No. 6 Fan	5
Revolving Flat Card-Production, 450 lbs. per week	3/4

Revolving Flat Card-Production, 700 lbs. per week	1
Revolving Flat Card-Production, 1,000 lbs. per week	1-1/4
Sliver Lap Machine	1/2
Ribbon Lap Machine	1
Comber—6-Head	1/2
Comber—8-Head	2/3
Drawing Frames, Ordinary Rolls, 6 delvs. per	1
Drawing Frames, Metallic Rolls, 5 delvs. per	1
Slubbing Frame, 45 spdls. per	1
Intermediate Frame, 55 spdls. per	1
Roving Frame, 85 spdls. per	1
Jack or Fine Roving Frame, 100 spdls. per	1
Spinning Frame, Warp yarns	
16s and coarser, 70 spdls. per	1
22s, 75 spdls. per	1
40s, 80 spdls. per	1
{239}	
60s, 90 spdls. per	1
80s, 100 spdls. per	1
Spinning Frame, Filling Yarns.	
16s and coarser, 110 spdls. per	1
22s, 90 spdls. per	1
28s, 85 spdls. per	1
40s, 90 spdls. per	1
70s, 100 spdls. per	1
90s, 110 spdls. per	1
Twister, 40 to 100 spdls. per	1
Cone Winder, 65 Drums per	1
Mule Spinning, 90 to 125 spdls. per	1
Spoolers, 150 to 250 spdls. per	1
Warper	1/4
Ball Warper	1/2
Slasher	1-1/2
Plain Loom, 40 in.	1/4
Wide Loom, 92 in.	1
Reel, 50 spdls.	5
Brusher and Shearer	3
Cloth Folder	1/3

NOTE—The above figures are only approximate, and give a fair average of the power taken to drive the various machines. The speed, production and many other conditions affect the power consumed.

{240}

BELTING REQUIRED FOR VARIOUS MACHINES

For convenience in calculating the quantity of belting required when equipping a mill or ordering supplies, the following lists have been prepared. Actual lengths are stated, no allowance being made for lap of belts or for splicing bands. All widths shown are for single belts.

HOPPER BALE OPENER.

Main Belt, 3 in.—8 ft. 6 in. of 2 in. (for 1 Belt).

SELF-FEEDING OPENER WITH 18-IN. RIGID BEATER FOR TRUNKING CONNECTION.

Main Belt, 3-1/2 in.—29 ft. 4 in. of 2 in. (for 3 Belts).

SELF-FEEDING OPENER WITH 30-IN. CYLINDER ARRANGED FOR TRUNKING CONNECTION.

Main Belt, 3-1/2 in.—30 ft. 5 in. of 2 in. (for 3 Belts).

SELF-FEEDING OPENER (18-IN. RIGID BEATER) WITH ONE BEATER BREAKER LAPPER.

Main Belt, 5 in. 33 ft. 5 in. of 3-1/2 in. (for 2 Belts).
 59 ft. 5 in. of 2 in. (for 6 Belts).

SELF-FEEDING OPENER (30-IN. CYLINDER) WITH ONE BEATER BREAKER LAPPER.

Main Belt, 5 in. 33 ft. 10 in. of 3-1/2 in. (for 2 Belts).
 60 ft. 6 in. of 2 in. (for 6 Belts).

SELF-FEEDING OPENER (18-IN. RIGID BEATER) WITH TWO BEATER BREAKER LAPPER.

Main Belt, 6 in. 56 ft. 11 in. of 3-1/2 in. (for 3 Belts).
 71 ft. 0 in. of 2 in. (for 7 Belts).

SELF-FEEDING OPENER (30-IN. CYLINDER) WITH TWO BEATER BREAKER LAPPER.

Main Belt, 6 in. 58 ft. 3 in. of 3-1/2 in. (for 3 Belts).
 72 ft. 1 in. of 2 in. (for 7 Belts).

ONE BEATER BREAKER LAPPER WITH GAUGE BOX AND CONDENSER.

Main Belt, 5 in. 15 ft. 3 in. of 3-1/2 in. (for 1 Belt).
 32 ft. 1 in. of 2 in. (for 3 Belts).
 12 ft. 8 in. of 1-1/2 in. (for 1 Belt).

TWO BEATER BREAKER LAPPER WITH GAUGE BOX AND CONDENSER.

Main Belt, 6 in. 33 ft. 5 in. of 3-1/2 in. (for 2 Belts).
 40 ft. 7 in. of 2 in. (for 4 Belts).
 12 ft. 8 in. of 1-1/2 in. (for 1 Belt).

{241}

ONE BEATER BREAKER LAPPER WITH CAGE SECTION.

Main Belt, 5 in. 15 ft. 3 in. of 3-1/2 in. (for 1 Belt).
 33 ft. 2 in. of 2 in. (for 3 Belts).

TWO BEATER BREAKER LAPPER WITH CAGE SECTION.

Main Belt, 6 in.

33 ft. 5 in. of 3-1/2 in. (for 2 Belts).

41 ft. 8 in. of 2 in. (for 4 Belts).

ONE BEATER INTERMEDIATE OR FINISHER LAPPER.

Main Belt, 4 in.

15 ft. 3 in. of 3-1/2 in. (for 1 Belt).

17 ft. 10 in. of 2 in. (for 2 Belts).

4 ft. 6 in. of 1 in. (for 1 Belt).

TWO BEATER INTERMEDIATE OR FINISHER LAPPER.

Main Belt, 5 in.

33 ft. 5 in. of 3-1/2 in. (for 2 Belts).

29 ft. 5 in. of 2 in. (for 3 Belts).

4 ft. 6 in. of 1 in. (for 1 Belt).

REVOLVING FLAT CARD.

Main Belt, 3 in.

Without Slow Motion.

14 ft. 7 in. of 2 in. (for 2 Belts).

13 ft. 2 in. of 1-1/2 in. (for 1 Belt).

22 ft. 9 in. of 5/16 in. dia. cotton Banding (for 3 Bands).

With Slow Motion.

14 ft. 7 in. of 2 in. (for 2 Belts).

23 ft. 4 in. of 1 in. (for 2 Belts).

22 ft. 9 in. of 5/16 in. dia. cotton Banding (for 3 Bands).

DRAWING FRAME.

Main Belt, 3 in. to 4 in.—9 ft. 9 in. of 1-1/2-in. belt required for each Head.

SLUBBING, INTERMEDIATE AND ROVING FRAMES.

Main Belt, 3 in.

11-in. or 12-in. lift: 7 ft. 3 in. of 2-in. belt (for Cone Drums).

9-in. or 10-in. lift: 6 ft. 8 in. of 2-in. belt (for Cone Drums).

8-in. lift: 5 ft. 11 in. of 2-in. belt (for Cone Drums).

6-in. or 7-in. lift: 5 ft. 8 in. of 2-in. belt (for Cone Drums).

RING SPINNING FRAME AND TWISTER.

Main Belt, 3 in.

CONE WINDER.

Main Belt, 2-1/2 in.

{242}

SHAFTING.

**HORSE-POWER TRANSMITTED BY COLD ROLLED SHAFTING. FIRST MOVERS OR HEAD SHAFTS
WELL SUPPORTED BY BEARINGS.**

Dia. of Shaft	Revolutions per Minute								
	100	150	200	225	250	275	300	325	350
	Horse-power								
2	8	12	16	18	20	22	24	26	28
2¼	11	17	23	26	28	31	34	37	40
2½	16	23	31	35	39	43	47	51	55
2¾	21	31	42	47	52	57	62	68	73
3	27	41	54	61	68	74	81	88	95
3¼	34	51	69	77	86	94	103	112	120
3½	43	64	86	96	107	118	129	139	150
3¾	53	79	105	119	132	145	158	171	185
4	64	96	128	144	160	176	192	208	224
4¼	77	115	154	173	192	211	230	249	269
4½	91	137	182	205	228	251	273	296	319
4¾	107	161	214	241	268	295	322	348	375
5	125	187	250	281	312	344	375	406	438
5¼	145	217	289	326	362	398	434	470	506
5½	166	250	333	374	416	458	499	541	582
5¾	190	285	380	428	475	523	570	618	665
6	216	324	432	486	540	594	648	702	756
6¼	244	366	488	549	610	671	732	793	854
6½	275	412	549	618	687	755	824	892	961
6¾	308	461	615	692	769	846	923	1000	1076
7	343	515	686	772	858	943	1029	1115	1201
7¼	381	572	762	857	953	1048	1143	1239	1335
7½	422	633	844	949	1055	1160	1266	1371	1477
7¾	465	698	931	1047	1164	1280	1396	1513	1629
8	512	768	1024	1152	1280	1408	1536	1664	1792

The above table is figured by the following rule: Multiply the cube of the diameter of the shaft by the revolutions per minute and divide by 100.

{243}

The table on the opposite page applies to head shafts supported by bearings close to each side of the main pulley so as to wholly guard against the transverse strain.

To find the diameter of shaft necessary to carry safely the main pulley at the center of a bay, use the table given below in connection with the one on the opposite page.

Dia. of Shaft Given by the Formula for Head Shafts	Dia. of Shaft necessary to carry the load at the Center of a Bay, which is from Center to Center of Bearings as below							
	2½ Ft.	3 Ft.	3½ Ft.	4 Ft.	5 Ft.	6 Ft.	8 Ft.	10 Ft.
	In.	In.	In.	In.	In.	In.	In.	In.
2	2⅛	2¼	2⅜	2½	2⅝	2¾	2⅞	3
2½	2½	2⅝	2¾	2⅞	3	3⅛	3⅜	3⅝
3	3	3⅛	3¼	3⅝	3½	3¾	4	4¼
3½		3½	3⅝	3¾	4	4¼	4½	4¾
4		4	4⅛	4¼	4½	4¾	5⅛	5⅜
4½			4½	4⅝	4⅞	5⅛	5½	5⅞
5			5	5⅛	5⅝	5⅞	6	6½
5½				5½	5¾	6	6½	6⅞
6				6	6⅜	6⅝	7⅛	7½

{244}

SHAFTING.

HORSE-POWER TRANSMITTED BY COLD ROLLED SHAFTING. SECOND MOVERS OR LINE SHAFTS WITH BEARINGS 8 FEET APART.

Dia. of Shaft	Revolutions per Minute								
	100	150	200	225	250	275	300	325	350
	Horse-power								
1 1/8	15	22	29	33	36	40	44	47	51
1 3/8	21	31	42	47	52	58	63	68	73
1 7/8	29	43	58	65	72	80	87	94	101
2 1/8	39	58	78	87	97	107	116	126	136
2 3/8	51	76	101	114	127	139	152	165	177
2 7/8	65	97	130	146	162	178	194	210	227
3 1/8	81	122	162	183	203	223	244	264	284
3 3/8	100	150	201	226	251	276	301	326	351
3 7/8	122	183	244	275	305	336	366	397	427
4 1/8	147	220	294	330	367	404	441	477	514
4 3/8	175	262	350	393	437	481	524	568	612
4 7/8	206	309	412	463	515	566	618	669	721
5 1/8	241	361	481	542	602	662	722	782	843
5 3/8	279	419	559	629	698	768	838	908	978
5 7/8	322	482	643	724	804	884	965	1045	1125
6 1/8	368	552	736	828	920	1012	1104	1196	1288
6 3/8	419	628	837	942	1047	1151	1256	1361	1465
6 7/8	474	711	948	1066	1185	1303	1421	1540	1658
7 1/8	534	800	1067	1201	1334	1467	1601	1734	1867
7 3/8	598	897	1196	1346	1496	1645	1795	1944	2094
7 7/8	668	1002	1336	1503	1669	1836	2003	2170	2337
8 1/8	743	1114	1485	1671	1857	2042	2228	2414	2599
8 3/8	823	1234	1646	1851	2057	2263	2468	2674	2880
8 7/8	909	1363	1817	2045	2272	2499	2726	2953	3180
9 1/8	1000	1500	2000	2250	2501	2751	3001	3251	3501

The above table is figured by the following rule: Multiply the cube of the diameter of the shaft by the revolutions per minute and divide by 50.

{245}

The table on the opposite page applies to Line Shafts with bearings 8 feet apart. To find the proper diameter for Line Shafts with bearings any other distance apart, multiply the diameter given in the table on the opposite page by the Constant Number corresponding to the distance between bearings in the table below.

Distance Between Bearings	Constant Number	Distance Between Bearings	Constant Number
Ft. In.		Ft. In.	
2 0	.354	7 6	.9527
2 6	.418	8 0	1.00
3 0	.479	8 6	1.0465
3 6	.538	9 0	1.092
4 0	.595	9 6	1.137
4 6	.6495	10 0	1.182
5 0	.7029	10 6	1.226
5 6	.755	10 9	1.248
6 0	.806	11 0	1.269
6 6	.856	11 6	1.315
7 0	.905	12 0	1.355

{246}

HORSE-POWER OF SINGLE BELTS.

PULLEYS—100 R. P. M.—BELT CONTACT 1/2 CIRCUM.

Dia. of Pulley	Width of Single Belt in Inches							
	3	4	5	6	8	10	12	14
6	.59	.78	.98	1.2	1.6	2.0	2.4	2.7
7	.69	.92	1.2	1.4	1.8	2.3	2.8	3.2
8	.78	1.0	1.3	1.6	2.1	2.6	3.1	3.7
9	.88	1.2	1.5	1.8	2.3	2.9	3.5	4.1
10	.98	1.3	1.6	2.0	2.6	3.2	3.9	4.6
11	1.1	1.4	1.8	2.2	2.9	3.6	4.3	5.0
12	1.2	1.6	2.0	2.4	3.1	3.9	4.7	5.5
13	1.3	1.7	2.1	2.5	3.4	4.2	5.1	5.9
14	1.4	1.8	2.3	2.8	3.7	4.6	5.5	6.4
15	1.5	2.0	2.5	3.0	3.9	4.9	5.9	6.9
16	1.6	2.1	2.6	3.1	4.2	5.2	6.3	7.3
17	1.7	2.2	2.8	3.3	4.5	5.6	6.7	7.8
18	1.8	2.4	3.0	3.5	4.7	5.9	7.1	8.3
19	1.9	2.5	3.1	3.7	5.0	6.2	7.5	8.7
20	2.0	2.6	3.3	3.9	5.2	6.6	7.9	9.2
21	2.1	2.7	3.4	4.1	5.5	6.9	8.2	9.6
22	2.2	2.9	3.6	4.3	5.8	7.2	8.6	10.1
23	2.3	3.0	3.8	4.5	6.0	7.5	9.0	10.5
24	2.4	3.1	3.9	4.7	6.3	7.9	9.4	11.0
25	2.5	3.3	4.1	4.9	6.6	8.2	9.8	11.5
26	2.6	3.4	4.3	5.1	6.8	8.5	10.2	11.9
27	2.7	3.5	4.4	5.3	7.1	8.8	10.6	12.4
28	2.8	3.7	4.6	5.5	7.3	9.2	11.0	12.8
29	2.9	3.8	4.8	5.7	7.6	9.5	11.4	13.2
30	2.9	3.9	4.9	5.9	7.9	9.8	11.8	13.7
31	3.0	4.1	5.1	6.1	8.1	10.2	12.2	14.2
32	3.1	4.2	5.2	6.3	8.4	10.5	12.6	14.7
33	3.2	4.3	5.4	6.5	8.6	10.8	13.0	15.1
34	3.3	4.4	5.6	6.7	8.9	11.1	13.3	15.5
35	3.4	4.6	5.7	6.9	9.2	11.5	13.7	16.0
36	3.5	4.7	5.9	7.1	9.4	11.8	14.2	16.5
37	3.6	4.8	6.1	7.3	9.7	12.1	14.5	16.9
38	3.7	5.0	6.2	7.4	9.9	12.4	14.9	17.4
39	3.8	5.1	6.4	7.7	10.2	12.8	15.3	17.9
40	3.9	5.2	6.6	7.9	10.5	13.1	15.7	18.3
42	4.1	5.5	6.9	8.2	11.0	13.7	16.4	19.2
44	4.3	5.8	7.2	8.6	11.5	14.4	17.3	20.2
46	4.5	6.0	7.5	9.0	12.0	15.0	18.0	21.0
48	4.7	6.3	7.9	9.4	12.6	15.7	18.8	22.0
50	4.9	6.5	8.2	9.8	13.0	16.3	19.6	22.8
52	5.1	6.8	8.5	10.2	13.6	17.0	20.4	23.8
54	5.3	7.1	8.8	10.6	14.2	17.7	21.2	24.7

NOTE—The above table is based on one Horse-power per inch of width for each 800 feet per minute belt speed. The horse-power for other pulley speeds in proportion.

{247}

HORSE-POWER OF DOUBLE BELTS.**PULLEYS—100 R. P. M.—BELT CONTACT 1/2 CIRCUM.**

Dia. of Pulley	Width of Double Belt in Inches							
	3	4	5	6	7	8	9	10
18	2.8	3.8	4.7	5.7	6.6	7.6	8.5	9.4
19	3.0	4.0	5.0	6.0	7.0	8.0	9.0	9.9
20	3.1	4.2	5.2	6.3	7.3	8.4	9.4	10.5
21	3.3	4.4	5.5	6.6	7.7	8.8	9.9	11.0
22	3.5	4.6	5.8	6.9	8.1	9.2	10.4	11.5
23	3.6	4.8	6.0	7.2	8.4	9.6	10.8	12.0
24	3.8	5.0	6.3	7.6	8.8	10.1	11.3	12.6
25	3.9	5.2	6.5	7.8	9.2	10.4	11.8	13.1
26	4.1	5.4	6.8	8.2	9.5	10.9	12.2	13.6
27	4.2	5.7	7.1	8.5	9.9	11.3	12.7	14.1
28	4.4	5.9	7.3	8.8	10.3	11.7	13.2	14.7
29	4.6	6.1	7.6	9.1	10.6	12.1	13.7	15.2
30	4.7	6.3	7.9	9.4	11.0	12.6	14.1	15.7
31	4.9	6.5	8.1	9.7	11.4	13.0	14.6	16.2
32	5.0	6.7	8.4	10.0	11.7	13.4	15.1	16.7
33	5.2	6.9	8.6	10.4	12.1	13.8	15.5	17.3
34	5.3	7.1	8.9	10.7	12.5	14.2	16.0	17.8
35	5.5	7.3	9.2	11.0	12.8	14.7	16.5	18.3
36	5.7	7.5	9.4	11.3	13.2	15.1	17.0	18.9
37	5.8	7.7	9.7	11.6	13.6	15.5	17.4	19.4
38	6.0	8.0	10.0	11.9	13.9	15.9	17.9	19.9
39	6.1	8.2	10.2	12.3	14.3	16.3	18.4	20.4
40	6.3	8.4	10.5	12.6	14.7	16.8	18.8	20.9
42	6.6	8.8	11.0	13.2	15.4	17.6	19.8	22.0
44	6.9	9.2	11.5	13.8	16.1	18.4	20.7	23.0
46	7.2	9.6	12.0	14.5	16.9	19.3	21.7	24.1
48	7.5	10.1	12.6	15.1	17.6	20.1	22.6	25.1
50	7.9	10.5	13.1	15.7	18.3	20.9	23.6	26.2
52	8.2	10.9	13.6	16.3	19.1	21.8	24.5	27.2
54	8.5	11.3	14.1	17.0	19.8	22.6	25.4	28.3
56	8.8	11.7	14.7	17.6	20.5	23.5	26.4	29.3
58	9.1	12.1	15.2	18.2	21.3	24.3	27.3	30.4
60	9.4	12.6	15.7	18.8	22.0	25.1	28.3	31.4
64	10.1	13.4	16.8	20.1	23.5	26.8	30.2	33.5
68	10.7	14.2	17.8	21.4	24.9	28.5	32.0	35.6
72	11.3	15.1	18.8	22.6	26.4	30.2	33.9	37.7
76	11.9	15.9	19.9	23.9	27.9	31.8	35.8	39.8
80	12.6	16.8	20.9	25.1	29.3	33.5	37.7	41.9
84	13.2	17.6	22.0	26.4	30.8	35.2	39.6	44.0
88	13.8	18.4	23.0	27.6	32.3	36.9	41.5	46.1
92	14.5	19.3	24.1	28.9	33.7	38.5	43.3	48.2
96	15.1	20.1	25.1	30.2	35.2	40.2	45.2	50.3

NOTE—The above table is based on one Horse-power per inch of width for each 500 feet per minute belt speed. The horse-power for other pulley speeds in proportion.

{248}

HORSE-POWER OF DOUBLE BELTS.

PULLEYS—100 R. P. M.—BELT CONTACT 1/2 CIRCUM.

Dia. of Pulley	Width of Double Belt in Inches							
	12	14	16	18	20	22	24	26
18	11.3	13.2	15.1	17.0	18.9	20.7	22.6	24.5
19	11.9	13.9	15.9	17.9	19.9	21.9	23.9	25.9
20	12.6	14.7	16.8	18.8	20.9	23.0	25.1	27.2
21	13.2	15.4	17.6	19.8	22.0	24.2	26.4	28.6
22	13.8	16.1	18.4	20.7	23.0	25.3	27.6	29.9
23	14.4	16.8	19.3	21.7	24.1	26.5	28.9	31.3
24	15.1	17.6	20.1	22.6	25.1	27.6	30.2	32.7
25	15.7	18.3	20.9	23.5	26.2	28.7	31.3	34.0
26	16.3	19.1	21.8	24.5	27.2	29.9	32.7	35.4
27	17.0	19.8	22.6	25.4	28.3	31.1	33.9	36.8
28	17.6	20.5	23.5	26.4	29.3	32.2	35.2	38.1
29	18.2	21.3	24.3	27.3	30.4	33.4	36.4	39.5
30	18.8	22.0	25.1	28.3	31.4	34.6	37.7	40.8
31	19.5	22.7	25.9	29.2	32.4	35.7	38.9	42.2
32	20.1	23.4	26.8	30.1	33.5	36.8	40.2	43.6
33	20.7	24.2	27.6	31.1	34.6	38.0	41.5	44.9
34	21.4	24.9	28.5	32.0	35.6	39.2	42.7	46.3
35	22.0	25.7	29.3	33.0	36.6	40.3	44.0	47.6
36	22.6	26.4	30.1	33.9	37.7	41.5	45.2	49.0
37	23.2	27.1	31.0	34.9	38.7	42.6	46.5	50.4
38	23.9	27.9	31.8	35.8	39.8	43.8	47.8	51.7
39	24.5	28.6	32.7	36.7	40.8	44.9	49.0	53.1
40	25.1	29.3	33.5	37.7	41.9	46.1	50.3	54.5
42	26.4	30.8	35.2	39.6	44.0	48.4	52.8	57.2
44	27.6	32.2	36.8	41.4	46.1	50.7	55.3	59.9
46	28.9	33.7	38.5	43.4	48.2	53.0	57.8	62.6
48	30.1	35.2	40.2	45.2	50.3	55.3	60.3	65.3
50	31.4	36.7	41.9	47.1	52.4	57.6	62.8	68.1
52	32.7	38.2	43.5	49.0	54.4	59.9	65.3	70.8
54	33.9	39.6	45.2	50.9	56.5	62.2	67.9	73.5
56	35.2	41.0	46.9	52.8	58.6	64.5	70.4	76.2
58	36.4	42.5	48.6	54.6	60.7	66.8	72.9	78.9
60	37.7	44.0	50.2	56.5	62.8	69.1	75.4	81.7
64	40.2	46.9	53.6	60.3	67.0	73.7	80.4	87.1
68	42.7	49.8	57.0	64.1	71.2	78.3	85.4	92.6
72	45.2	52.8	60.3	67.9	75.4	82.9	90.5	98.0
76	47.7	55.7	63.7	71.6	79.6	87.5	95.5	103.5
80	50.3	58.6	67.0	75.4	83.8	92.1	100.5	108.9
84	52.8	61.6	70.4	79.2	87.9	96.7	105.5	114.4
88	55.3	64.5	73.7	82.9	92.2	101.4	110.6	119.8
92	57.8	67.4	77.1	86.7	96.3	106.0	115.6	125.2
96	60.3	70.4	80.4	90.5	100.5	110.6	120.6	130.7

NOTE—The above table is based on one Horse-power per inch of width for each 500 feet per minute belt speed. The horse-power for other pulley speeds in proportion.

{249}

USEFUL CONSTANTS, ETC.

1 pint of water weighs a pound and a quarter.
1 gal. of water = .1605 cu. ft. = 10 lb. of water at 62° F.
1 knot = 6080 ft. = 1.15 statute miles.
1 lb. (avoirdupois) = 7,000 grains = 453.6 grammes.
1 lb. (Troy) = 5,760 grains.
1 English h. p. = 33,000 ft. lbs. of work done per min. = 746 watts.
1 French h. p. or force de cheval = 4,500 kilogram metres per min. = .9863 English h. p.
1 English h. p. = 1.01385 French force de cheval.
1 board of trade electrical unit = 1,000 watts per hour.
Volts X amperes = watts.
The pressure of one atmosphere = 14.7 lbs. per sq. in. = 2,116 lbs. per sq. ft. = a column of mercury 760 m/m high.
A column of water 2.3 ft. high corresponds to a pressure of 1 lb. per sq. in.
Cubic inches of cast iron X 0.26 = lbs. avoirdupois.
Cubic inches of wrought iron X 0.28 = lbs. avoirdupois.
Thickness of wrought iron plate in inches X 40 = lbs. per sq. ft.
Sectional area of wrought iron in inches X 3.34 = lbs. per lineal ft.
Dia. of wrought iron in inches squared X 2.64 = lbs. per lineal ft.

CIRCUMFERENCES OF CIRCLES, ADVANCING BY 8THS.

Inches Dia.	Circumferences							
	0	$\frac{1}{8}$	$\frac{1}{4}$	$\frac{3}{8}$	$\frac{1}{2}$	$\frac{5}{8}$	$\frac{3}{4}$	$\frac{7}{8}$
0	0.3927	0.7854	1.178	1.570	1.963	2.356	2.748
1	3.1416	3.534	3.927	4.319	4.712	5.105	5.497	5.890
2	6.283	6.675	7.068	7.461	7.854	8.246	8.639	9.032
3	9.424	9.817	10.21	10.60	10.99	11.38	11.78	12.17
4	12.56	12.95	13.35	13.74	14.13	14.52	14.92	15.31
5	15.70	16.10	16.49	16.88	17.27	17.67	18.06	18.45
6	18.84	19.24	19.63	20.02	20.42	20.81	21.20	21.59

Circum. of a circle = dia. X 3.1416

MENSURATION OF SURFACES, SOLIDS, ETC.

Area of triangle = base X half the perpendicular height.

Area of circle = dia.² X 0.7854.

Circum. of circle = dia. X 3.14159.

Circum. of circle X .31831 = the dia.

Dia. of circle X .8862 = the side of an equal square.

Side of a square X 1.12837 = the dia. of equal circle.

Square root of an area X 1.12837 = the dia. of equal circle.

Surface of cylinder = area of both ends + length X circum.

Surface of cone = area of base + 1/2 (slant height X circum. of base).

Surface of sphere = dia. squared X 3.14159.

Solidity of sphere = dia. cubed X .5236.

Solidity of cylinder = area of one end X length.

{250}

DATA ON MANILA TRANSMISSION ROPE.

(AMERICAN MFG. CO.)

Dia. of Rope	Square of Dia.	Ap- proxi- mate Wgt. per Ft.	Break- ing Strgth.	Maxi- mum Allow- able Tension	Length of Splice Feet			Small- est Dia. of Sheaves, In.	Maxi- mum No. of Revs. per Minute
					3 Strands	4 Strands	6 Strands		
$\frac{3}{4}$.5625	.20	3,950	112	6	8	..	28	760
$\frac{7}{8}$.7656	.26	5,400	153	6	8	..	32	650
1	1	.34	7,000	200	7	10	14	36	570
$1\frac{1}{8}$	1.2656	.43	8,900	253	7	10	16	40	510
$1\frac{1}{4}$	1.5625	.53	10,900	312	7	10	16	46	460
$1\frac{3}{8}$	1.8906	.65	13,200	378	8	12	16	50	415
$1\frac{1}{2}$	2.25	.77	15,700	450	8	12	18	54	380
$1\frac{5}{8}$	2.6406	.90	18,500	528	8	12	18	60	344
$1\frac{3}{4}$	3.0625	1.04	21,400	612	8	12	18	64	330
2	4	1.36	28,000	800	9	14	20	72	290
$2\frac{1}{4}$	5.0625	1.73	35,400	1,012	9	14	20	82	255
$2\frac{1}{2}$	6.25	2.13	43,700	1,250	10	16	22	90	230

Weight of transmission rope = .34 X dia.²

Breaking strength = 7,000 X dia.²

Maximum allowable tension = 200 X dia.²

Dia. smallest practicable sheave. = 36 X dia.

Velocity of rope (assumed) = 5,400 ft. per minute.

{251}

HORSE-POWER TRANSMITTED BY MANILA ROPE.

Dia. of Rope	Velocity, Feet per Minute										
	1,000	1,500	2,000	2,500	3,000	3,500	4,000	4,500	5,000	5,500	6,000
$\frac{3}{4}$	2.3	3.3	4.3	5.2	6.0	6.6	7.2	7.3	7.4	7.3	6.9
$\frac{7}{8}$	3.0	4.5	5.9	7.0	8.2	9.0	9.6	9.8	10.0	9.6	9.0
1	4.0	5.9	7.7	9.2	10.6	11.8	12.7	12.9	13.0	12.7	12.0
$1\frac{1}{8}$	5.0	7.5	9.7	11.6	13.5	14.9	16.0	16.3	16.7	16.5	15.3
$1\frac{1}{4}$	6.3	9.1	12.0	14.3	16.7	18.5	20.0	20.2	20.7	20.1	18.9
$1\frac{3}{8}$	7.5	10.8	14.4	17.4	20.0	22.1	23.7	24.5	24.6	24.0	22.3
$1\frac{1}{2}$	9.0	13.5	17.4	20.7	23.0	25.3	27.7	29.0	29.5	28.6	26.7
$1\frac{5}{8}$	10.5	15.5	20.1	24.3	27.9	30.8	32.9	34.1	34.3	33.3	31.0
$1\frac{3}{4}$	12.3	18.0	23.6	28.2	32.7	36.4	38.5	39.4	40.5	38.7	36.0
2	16.0	23.2	30.6	36.8	42.5	46.7	50.0	51.7	52.8	50.6	47.3
$2\frac{1}{4}$	20.0	29.6	38.6	46.6	53.6	59.2	63.6	65.8	66.3	64.4	60.3
$2\frac{1}{2}$	25.0	36.6	47.7	57.5	66.0	71.2	78.0	80.0	81.0	79.0	73.8

SAG OF MANILA ROPE ON DRIVING AND SLACK SIDES.

Distance Between Pulleys, Feet	Sag on Driving Side, All Speeds, Ft.	Sag on Slack Side				
		Velocity, Feet per Minute				
		3,000	4,000	4,500	5,000	5,500
30	.19	.45	.39	.36	.33	.30
40	.34	.80	.69	.64	.59	.53
50	.53	1.2	1.1	1.0	.92	.84
60	.76	1.8	1.7	1.4	1.3	1.2
70	1.0	2.4	2.1	1.9	1.7	1.6
80	1.4	3.2	2.9	2.5	2.3	2.1
90	1.7	4.0	3.5	3.2	3.0	2.7
100	2.1	5.0	4.3	4.0	3.7	3.3
120	3.0	7.2	6.2	5.7	5.3	4.8
140	4.1	9.9	8.5	7.8	7.2	6.6
160	5.4	12.9	11.1	10.2	9.5	8.6

{252}

NUMBER OF RING AND MULE SPINDLES IN UNITED STATES.

(DEPART. OF COMMERCE AND LABOR REPORT, 1908.)

	Ring	Mule	Total
Maine	764,064	214,124	978,188
New Hampshire	1,045,283	275,220	1,320,503
Vermont	80,688	26,636	107,324
Massachusetts	7,060,977	2,385,403	9,446,380

Rhode Island	1,456,471	931,626	2,388,105
Connecticut	789,860	450,436	1,240,296
New York	474,154	454,162	928,316
Pennsylvania	134,268	134,042	268,310
New Jersey	108,690	338,339	447,029
Maryland	151,000		151,000
Virginia	289,639	5,940	295,579
North Carolina	2,852,540	91,864	2,944,404
South Carolina	3,700,974	12,032	3,713,006
Alabama	931,030	8,912	939,942
Georgia	1,694,768	98,022	1,792,790
Louisiana	82,252	7,300	89,552
Mississippi	173,111	105	173,216
Kentucky	58,580	27,120	85,700
Tennessee	253,448	11,750	265,198
Texas	103,708	3,216	106,924
Indiana	121,047	16,230	137,277
All other States	128,772	16,576	145,348
Total	22,455,332	5,509,055	27,964,387

{253}

WORLD'S COTTON SPINDLES.**(DEPART. OF COMMERCE AND LABOR REPORT, 1908.)**

United States		27,964,387
Europe:		
	United Kingdom	52,817,582
	Germany	9,882,505
	Russia	7,855,210
	France	6,731,316
	Italy	4,181,000
	Austria-Hungary	4,026,460
	Spain	1,850,000
	Switzerland	1,493,012
	Belgium	1,162,041
	Portugal	450,000
	Netherlands	396,160
	Sweden	390,000
	Denmark	77,644
	Norway	74,936
	All other Europe	185,000
British India		5,699,898
Japan		1,550,929

China		750,000
Brazil		1,300,000
Mexico		730,000
Canada		795,293
Other countries		150,000
Total		130,513,373

End of the Project Gutenberg EBook of Illustrated Catalogue of Cotton Machinery, by Howard & Bullough American Machine Company, Ltd.

*** END OF THIS PROJECT GUTENBERG EBOOK COTTON MACHINERY ***

***** This file should be named 38301-h.htm or 38301-h.zip *****
This and all associated files of various formats will be found in:
<http://www.gutenberg.org/3/8/3/0/38301/>

Produced by Don Kostuch

Updated editions will replace the previous one--the old editions will be renamed.

Creating the works from public domain print editions means that no one owns a United States copyright in these works, so the Foundation (and you!) can copy and distribute it in the United States without permission and without paying copyright royalties. Special rules, set forth in the General Terms of Use part of this license, apply to copying and distributing Project Gutenberg-tm electronic works to protect the PROJECT GUTENBERG-tm concept and trademark. Project Gutenberg is a registered trademark, and may not be used if you charge for the eBooks, unless you receive specific permission. If you do not charge anything for copies of this eBook, complying with the rules is very easy. You may use this eBook for nearly any purpose such as creation of derivative works, reports, performances and research. They may be modified and printed and given away--you may do practically ANYTHING with public domain eBooks. Redistribution is subject to the trademark license, especially commercial redistribution.

*** START: FULL LICENSE ***

THE FULL PROJECT GUTENBERG LICENSE
PLEASE READ THIS BEFORE YOU DISTRIBUTE OR USE THIS WORK

To protect the Project Gutenberg-tm mission of promoting the free distribution of electronic works, by using or distributing this work (or any other work associated in any way with the phrase "Project Gutenberg"), you agree to comply with all the terms of the Full Project Gutenberg-tm License (available with this file or online at <http://gutenberg.org/license>).

Section 1. General Terms of Use and Redistributing Project Gutenberg-tm electronic works

1.A. By reading or using any part of this Project Gutenberg-tm electronic work, you indicate that you have read, understand, agree to and accept all the terms of this license and intellectual property (trademark/copyright) agreement. If you do not agree to abide by all the terms of this agreement, you must cease using and return or destroy all copies of Project Gutenberg-tm electronic works in your possession. If you paid a fee for obtaining a copy of or access to a Project Gutenberg-tm electronic work and you do not agree to be bound by the terms of this agreement, you may obtain a refund from the person or entity to whom you paid the fee as set forth in paragraph 1.E.8.

1.B. "Project Gutenberg" is a registered trademark. It may only be used on or associated in any way with an electronic work by people who agree to be bound by the terms of this agreement. There are a few things that you can do with most Project Gutenberg-tm electronic works

even without complying with the full terms of this agreement. See paragraph 1.C below. There are a lot of things you can do with Project Gutenberg-tm electronic works if you follow the terms of this agreement and help preserve free future access to Project Gutenberg-tm electronic works. See paragraph 1.E below.

1.C. The Project Gutenberg Literary Archive Foundation ("the Foundation" or PGLAF), owns a compilation copyright in the collection of Project Gutenberg-tm electronic works. Nearly all the individual works in the collection are in the public domain in the United States. If an individual work is in the public domain in the United States and you are located in the United States, we do not claim a right to prevent you from copying, distributing, performing, displaying or creating derivative works based on the work as long as all references to Project Gutenberg are removed. Of course, we hope that you will support the Project Gutenberg-tm mission of promoting free access to electronic works by freely sharing Project Gutenberg-tm works in compliance with the terms of this agreement for keeping the Project Gutenberg-tm name associated with the work. You can easily comply with the terms of this agreement by keeping this work in the same format with its attached full Project Gutenberg-tm License when you share it without charge with others.

1.D. The copyright laws of the place where you are located also govern what you can do with this work. Copyright laws in most countries are in a constant state of change. If you are outside the United States, check the laws of your country in addition to the terms of this agreement before downloading, copying, displaying, performing, distributing or creating derivative works based on this work or any other Project Gutenberg-tm work. The Foundation makes no representations concerning the copyright status of any work in any country outside the United States.

1.E. Unless you have removed all references to Project Gutenberg:

1.E.1. The following sentence, with active links to, or other immediate access to, the full Project Gutenberg-tm License must appear prominently whenever any copy of a Project Gutenberg-tm work (any work on which the phrase "Project Gutenberg" appears, or with which the phrase "Project Gutenberg" is associated) is accessed, displayed, performed, viewed, copied or distributed:

This eBook is for the use of anyone anywhere at no cost and with almost no restrictions whatsoever. You may copy it, give it away or re-use it under the terms of the Project Gutenberg License included with this eBook or online at www.gutenberg.org

1.E.2. If an individual Project Gutenberg-tm electronic work is derived from the public domain (does not contain a notice indicating that it is posted with permission of the copyright holder), the work can be copied and distributed to anyone in the United States without paying any fees or charges. If you are redistributing or providing access to a work with the phrase "Project Gutenberg" associated with or appearing on the work, you must comply either with the requirements of paragraphs 1.E.1 through 1.E.7 or obtain permission for the use of the work and the Project Gutenberg-tm trademark as set forth in paragraphs 1.E.8 or 1.E.9.

1.E.3. If an individual Project Gutenberg-tm electronic work is posted with the permission of the copyright holder, your use and distribution must comply with both paragraphs 1.E.1 through 1.E.7 and any additional terms imposed by the copyright holder. Additional terms will be linked to the Project Gutenberg-tm License for all works posted with the permission of the copyright holder found at the beginning of this work.

1.E.4. Do not unlink or detach or remove the full Project Gutenberg-tm License terms from this work, or any files containing a part of this work or any other work associated with Project Gutenberg-tm.

1.E.5. Do not copy, display, perform, distribute or redistribute this electronic work, or any part of this electronic work, without prominently displaying the sentence set forth in paragraph 1.E.1 with active links or immediate access to the full terms of the Project Gutenberg-tm License.

1.E.6. You may convert to and distribute this work in any binary, compressed, marked up, nonproprietary or proprietary form, including any word processing or hypertext form. However, if you provide access to or distribute copies of a Project Gutenberg-tm work in a format other than "Plain Vanilla ASCII" or other format used in the official version posted on the official Project Gutenberg-tm web site (www.gutenberg.org), you must, at no additional cost, fee or expense to the user, provide a

copy, a means of exporting a copy, or a means of obtaining a copy upon request, of the work in its original "Plain Vanilla ASCII" or other form. Any alternate format must include the full Project Gutenberg-tm License as specified in paragraph 1.E.1.

1.E.7. Do not charge a fee for access to, viewing, displaying, performing, copying or distributing any Project Gutenberg-tm works unless you comply with paragraph 1.E.8 or 1.E.9.

1.E.8. You may charge a reasonable fee for copies of or providing access to or distributing Project Gutenberg-tm electronic works provided that

- You pay a royalty fee of 20% of the gross profits you derive from the use of Project Gutenberg-tm works calculated using the method you already use to calculate your applicable taxes. The fee is owed to the owner of the Project Gutenberg-tm trademark, but he has agreed to donate royalties under this paragraph to the Project Gutenberg Literary Archive Foundation. Royalty payments must be paid within 60 days following each date on which you prepare (or are legally required to prepare) your periodic tax returns. Royalty payments should be clearly marked as such and sent to the Project Gutenberg Literary Archive Foundation at the address specified in Section 4, "Information about donations to the Project Gutenberg Literary Archive Foundation."
- You provide a full refund of any money paid by a user who notifies you in writing (or by e-mail) within 30 days of receipt that s/he does not agree to the terms of the full Project Gutenberg-tm License. You must require such a user to return or destroy all copies of the works possessed in a physical medium and discontinue all use of and all access to other copies of Project Gutenberg-tm works.
- You provide, in accordance with paragraph 1.F.3, a full refund of any money paid for a work or a replacement copy, if a defect in the electronic work is discovered and reported to you within 90 days of receipt of the work.
- You comply with all other terms of this agreement for free distribution of Project Gutenberg-tm works.

1.E.9. If you wish to charge a fee or distribute a Project Gutenberg-tm electronic work or group of works on different terms than are set forth in this agreement, you must obtain permission in writing from both the Project Gutenberg Literary Archive Foundation and Michael Hart, the owner of the Project Gutenberg-tm trademark. Contact the Foundation as set forth in Section 3 below.

1.F.

1.F.1. Project Gutenberg volunteers and employees expend considerable effort to identify, do copyright research on, transcribe and proofread public domain works in creating the Project Gutenberg-tm collection. Despite these efforts, Project Gutenberg-tm electronic works, and the medium on which they may be stored, may contain "Defects," such as, but not limited to, incomplete, inaccurate or corrupt data, transcription errors, a copyright or other intellectual property infringement, a defective or damaged disk or other medium, a computer virus, or computer codes that damage or cannot be read by your equipment.

1.F.2. LIMITED WARRANTY, DISCLAIMER OF DAMAGES - Except for the "Right of Replacement or Refund" described in paragraph 1.F.3, the Project Gutenberg Literary Archive Foundation, the owner of the Project Gutenberg-tm trademark, and any other party distributing a Project Gutenberg-tm electronic work under this agreement, disclaim all liability to you for damages, costs and expenses, including legal fees. YOU AGREE THAT YOU HAVE NO REMEDIES FOR NEGLIGENCE, STRICT LIABILITY, BREACH OF WARRANTY OR BREACH OF CONTRACT EXCEPT THOSE PROVIDED IN PARAGRAPH 1.F.3. YOU AGREE THAT THE FOUNDATION, THE TRADEMARK OWNER, AND ANY DISTRIBUTOR UNDER THIS AGREEMENT WILL NOT BE LIABLE TO YOU FOR ACTUAL, DIRECT, INDIRECT, CONSEQUENTIAL, PUNITIVE OR INCIDENTAL DAMAGES EVEN IF YOU GIVE NOTICE OF THE POSSIBILITY OF SUCH DAMAGE.

1.F.3. LIMITED RIGHT OF REPLACEMENT OR REFUND - If you discover a defect in this electronic work within 90 days of receiving it, you can receive a refund of the money (if any) you paid for it by sending a written explanation to the person you received the work from. If you received the work on a physical medium, you must return the medium with

your written explanation. The person or entity that provided you with the defective work may elect to provide a replacement copy in lieu of a refund. If you received the work electronically, the person or entity providing it to you may choose to give you a second opportunity to receive the work electronically in lieu of a refund. If the second copy is also defective, you may demand a refund in writing without further opportunities to fix the problem.

1.F.4. Except for the limited right of replacement or refund set forth in paragraph 1.F.3, this work is provided to you 'AS-IS' WITH NO OTHER WARRANTIES OF ANY KIND, EXPRESS OR IMPLIED, INCLUDING BUT NOT LIMITED TO WARRANTIES OF MERCHANTABILITY OR FITNESS FOR ANY PURPOSE.

1.F.5. Some states do not allow disclaimers of certain implied warranties or the exclusion or limitation of certain types of damages. If any disclaimer or limitation set forth in this agreement violates the law of the state applicable to this agreement, the agreement shall be interpreted to make the maximum disclaimer or limitation permitted by the applicable state law. The invalidity or unenforceability of any provision of this agreement shall not void the remaining provisions.

1.F.6. INDEMNITY - You agree to indemnify and hold the Foundation, the trademark owner, any agent or employee of the Foundation, anyone providing copies of Project Gutenberg-tm electronic works in accordance with this agreement, and any volunteers associated with the production, promotion and distribution of Project Gutenberg-tm electronic works, harmless from all liability, costs and expenses, including legal fees, that arise directly or indirectly from any of the following which you do or cause to occur: (a) distribution of this or any Project Gutenberg-tm work, (b) alteration, modification, or additions or deletions to any Project Gutenberg-tm work, and (c) any Defect you cause.

Section 2. Information about the Mission of Project Gutenberg-tm

Project Gutenberg-tm is synonymous with the free distribution of electronic works in formats readable by the widest variety of computers including obsolete, old, middle-aged and new computers. It exists because of the efforts of hundreds of volunteers and donations from people in all walks of life.

Volunteers and financial support to provide volunteers with the assistance they need, are critical to reaching Project Gutenberg-tm's goals and ensuring that the Project Gutenberg-tm collection will remain freely available for generations to come. In 2001, the Project Gutenberg Literary Archive Foundation was created to provide a secure and permanent future for Project Gutenberg-tm and future generations. To learn more about the Project Gutenberg Literary Archive Foundation and how your efforts and donations can help, see Sections 3 and 4 and the Foundation web page at <http://www.pgla.org>.

Section 3. Information about the Project Gutenberg Literary Archive Foundation

The Project Gutenberg Literary Archive Foundation is a non profit 501(c)(3) educational corporation organized under the laws of the state of Mississippi and granted tax exempt status by the Internal Revenue Service. The Foundation's EIN or federal tax identification number is 64-6221541. Its 501(c)(3) letter is posted at <http://pglaf.org/fundraising>. Contributions to the Project Gutenberg Literary Archive Foundation are tax deductible to the full extent permitted by U.S. federal laws and your state's laws.

The Foundation's principal office is located at 4557 Melan Dr. S. Fairbanks, AK, 99712., but its volunteers and employees are scattered throughout numerous locations. Its business office is located at 809 North 1500 West, Salt Lake City, UT 84116, (801) 596-1887, email business@pglaf.org. Email contact links and up to date contact information can be found at the Foundation's web site and official page at <http://pglaf.org>

For additional contact information:

Dr. Gregory B. Newby
Chief Executive and Director
gnewby@pglaf.org

Section 4. Information about Donations to the Project Gutenberg Literary Archive Foundation

Project Gutenberg-tm depends upon and cannot survive without wide spread public support and donations to carry out its mission of increasing the number of public domain and licensed works that can be freely distributed in machine readable form accessible by the widest array of equipment including outdated equipment. Many small donations (\$1 to \$5,000) are particularly important to maintaining tax exempt status with the IRS.

The Foundation is committed to complying with the laws regulating charities and charitable donations in all 50 states of the United States. Compliance requirements are not uniform and it takes a considerable effort, much paperwork and many fees to meet and keep up with these requirements. We do not solicit donations in locations where we have not received written confirmation of compliance. To SEND DONATIONS or determine the status of compliance for any particular state visit <http://pglaf.org>

While we cannot and do not solicit contributions from states where we have not met the solicitation requirements, we know of no prohibition against accepting unsolicited donations from donors in such states who approach us with offers to donate.

International donations are gratefully accepted, but we cannot make any statements concerning tax treatment of donations received from outside the United States. U.S. laws alone swamp our small staff.

Please check the Project Gutenberg Web pages for current donation methods and addresses. Donations are accepted in a number of other ways including checks, online payments and credit card donations. To donate, please visit: <http://pglaf.org/donate>

Section 5. General Information About Project Gutenberg-tm electronic works.

Professor Michael S. Hart is the originator of the Project Gutenberg-tm concept of a library of electronic works that could be freely shared with anyone. For thirty years, he produced and distributed Project Gutenberg-tm eBooks with only a loose network of volunteer support.

Project Gutenberg-tm eBooks are often created from several printed editions, all of which are confirmed as Public Domain in the U.S. unless a copyright notice is included. Thus, we do not necessarily keep eBooks in compliance with any particular paper edition.

Most people start at our Web site which has the main PG search facility:

<http://www.gutenberg.org>

This Web site includes information about Project Gutenberg-tm, including how to make donations to the Project Gutenberg Literary Archive Foundation, how to help produce our new eBooks, and how to subscribe to our email newsletter to hear about new eBooks.